

Internal Dimensions		
Width	Depth	Height
1090	590	760
Weight	Approx. 74 Kg	
Wall Thickness		10mm

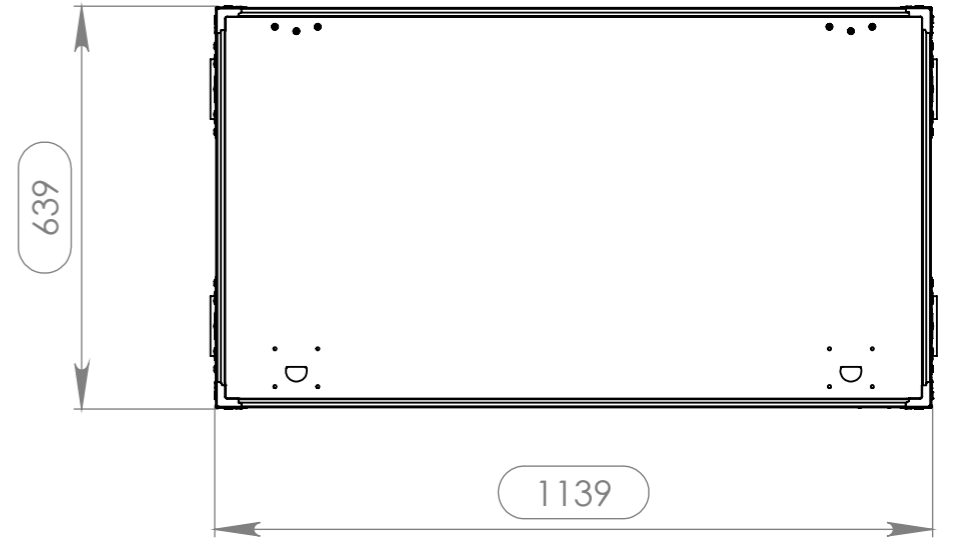
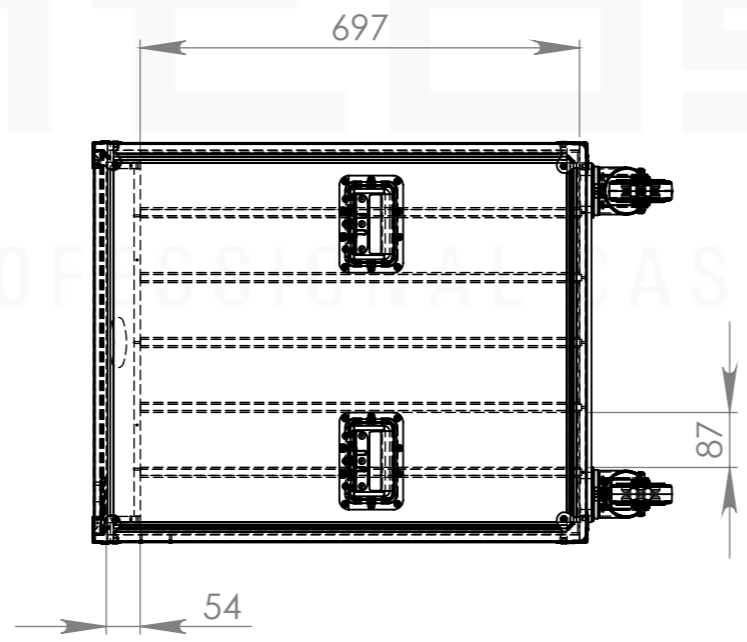
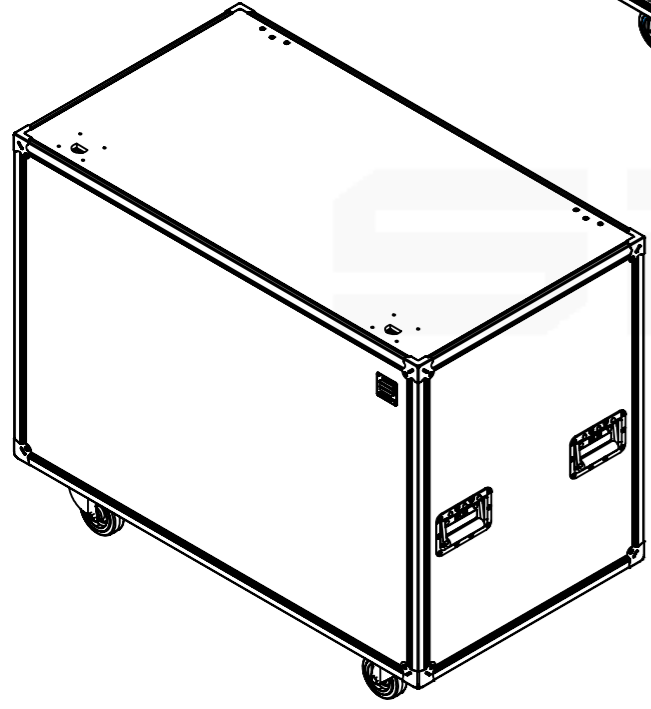
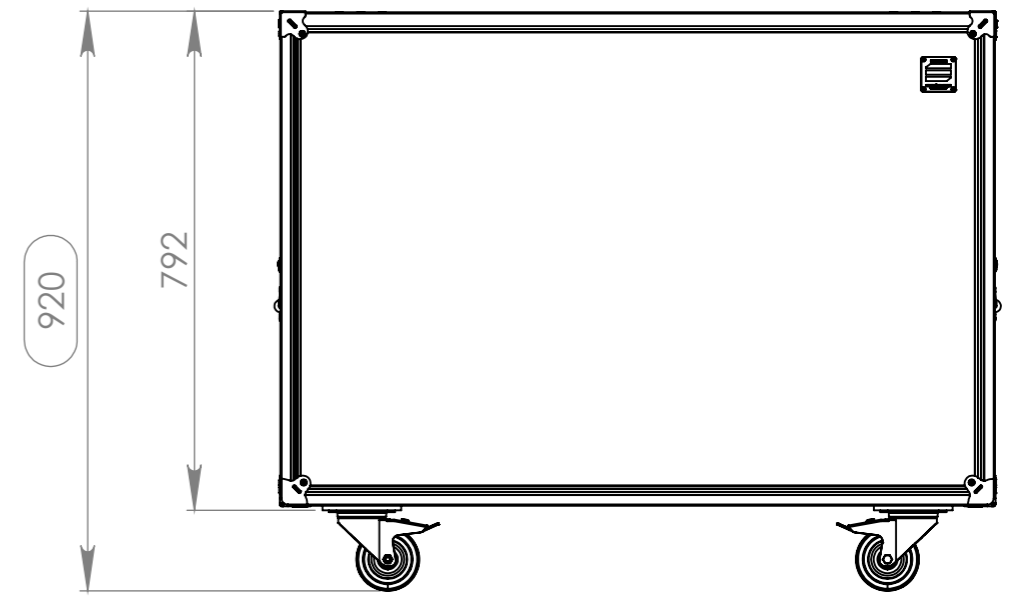
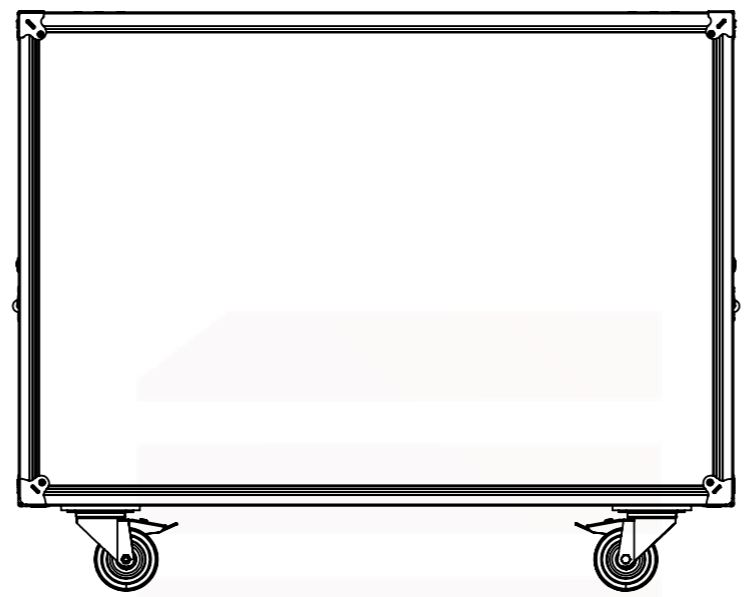
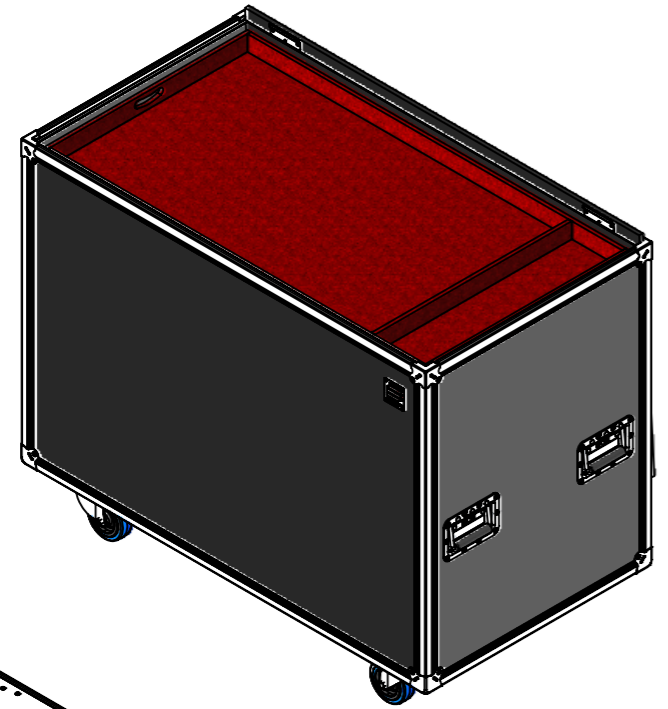

Hardware		
Qty	Ref.	Description
4	C0675-30Z	UX-BOX, Corner 2 LEG, 10mm
4	4004	Case corner zinc plated
2	16540	Sliding Latch System - Sliding Latch
4	34082	Recessed Sprung Handle Medium
2	RODA.100T	Swivel castor Ø100mm with brake
2	RODA.100	Swivel castor Ø100 mm
1	CHAPA.1000	Identification Plate

This drawing must not be copied or disclosed without consent of the owner

Drawn by	Name	Date
jorgepacheco	jorgepacheco	02/05/2017
Reference	XB2AR.1156580.01	
Scale	units in mm	general tolerance
1:12	DO NOT SCALE	0.8mm
1st Angle projection	FC XBR. 1090X590X760 6 ESPAÇOS GAMELA	

