

Internal Dimensions

Width	Depth	Height
1556	396	200
Weight	Approx. 22 Kg	
Wall Thickness		10mm

REVISIONS

REV.	DESCRIPTION	DATE	APPROVED
1	Hinges changed to Ref. 2524	20-10-2017	Alexandre

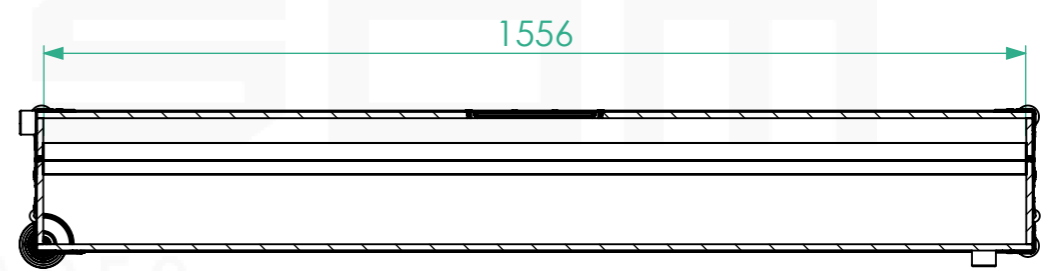
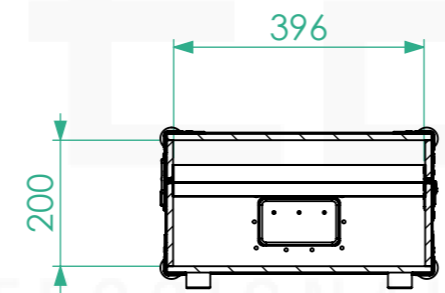
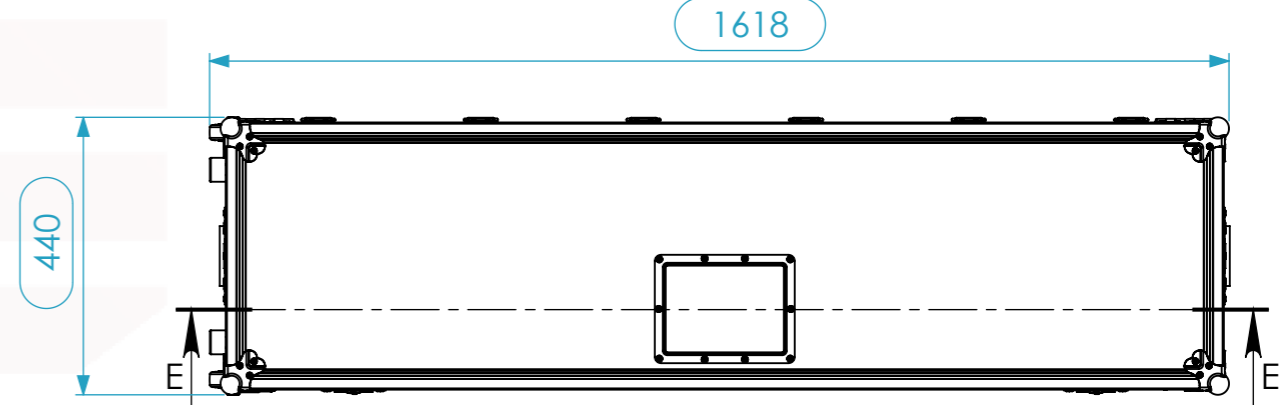
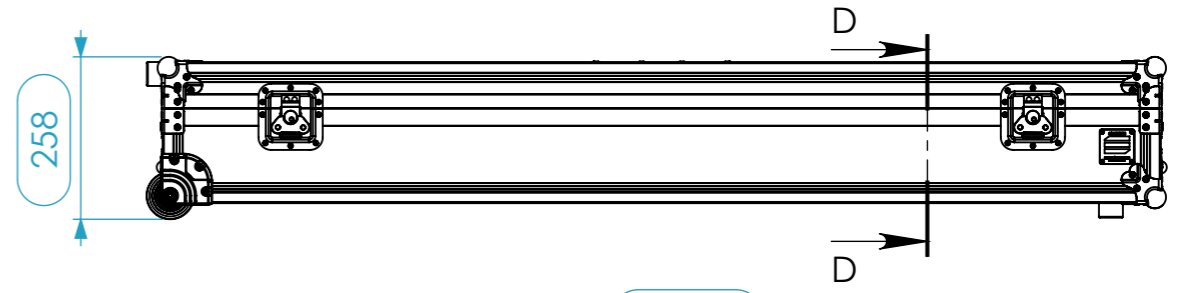
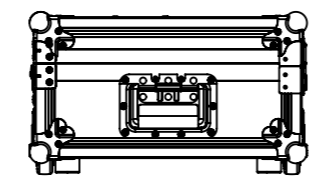
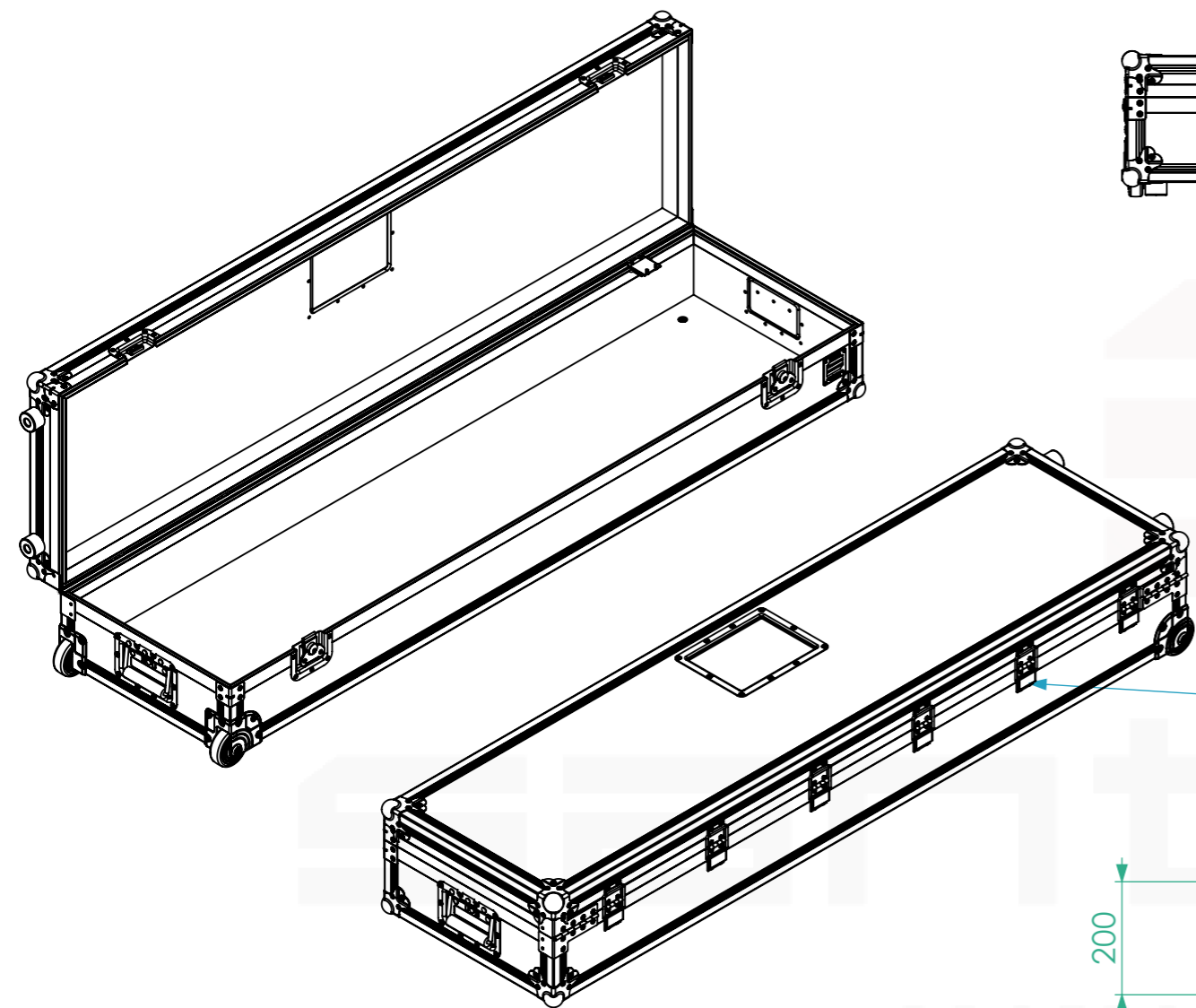

Hardware

Qty	Ref.	Description
2	34082	Recessed Sprung Handle Medium
2	17290S	Key lockable medium Butterfly special
1	CHAPA.1000	Identification Plate
6	410429	Heavy Duty Ball Corner
4	40403	Large corner bracket f. 35mm case angle
2	DCR110	Combination of Hinge and 2 Corner Braces
2	w8675	Corner Castor with Heavy Duty 75mm / 2.95", Blue Wheel
4	4911	Rubber foot 38 x 25 mm with steel insert
1	88001D	Dish for 88001 Tour Label
6	2524	Heavy Duty Strut Hinge

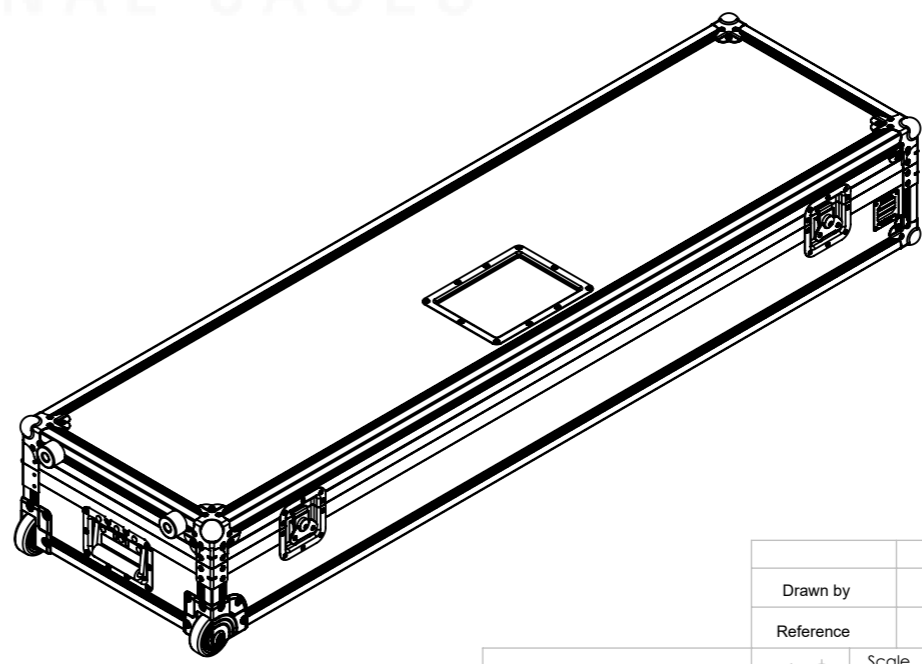

This drawing must not be copied or disclosed without consent of the owner

Drawn by	Name	Date
alexandre	alexandre	20-10-2017
Reference	X1AAR.1604424	
Scale	units in mm	general tolerance
1:12	DO NOT SCALE	0.8mm
1st Angle projection	FC, X1AA, 1556X396X200	

