

Standard External Dimensions		
Width	Depth	Height
550	400	800
Weight	Approx. 27 Kg	
Wall Thickness	10mm	

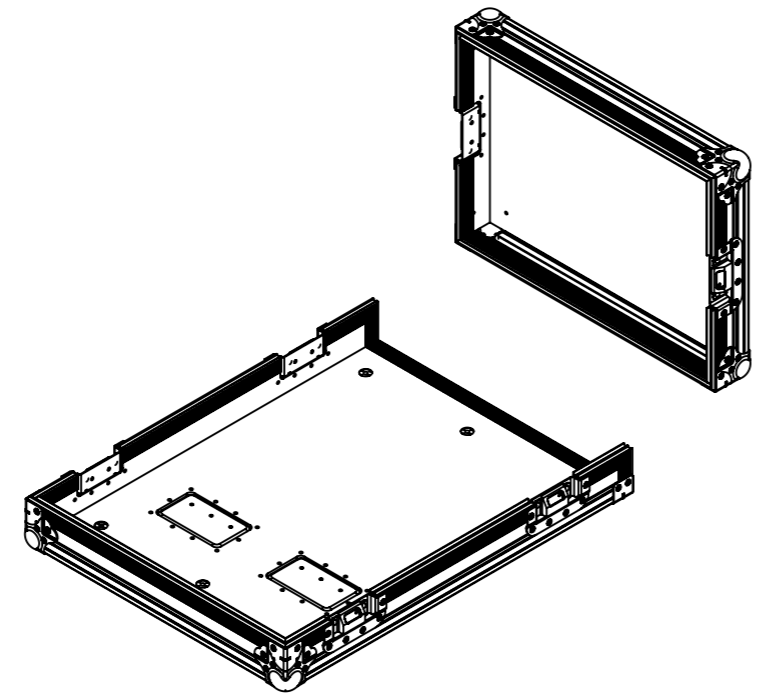

Feet made of wear-resistant PE-HD 500

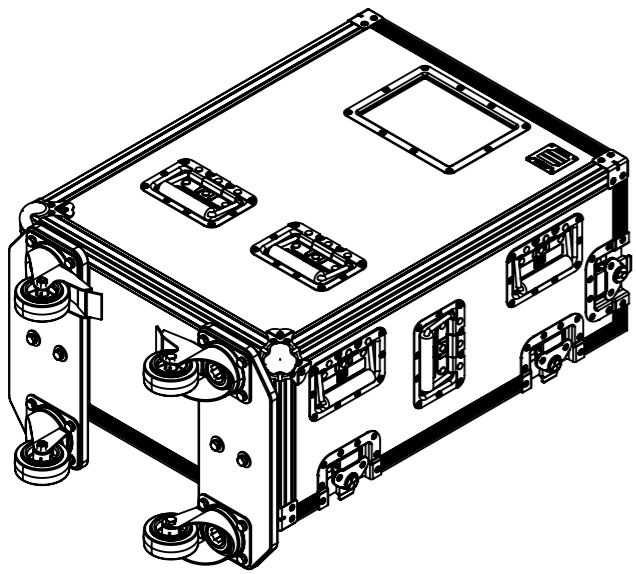
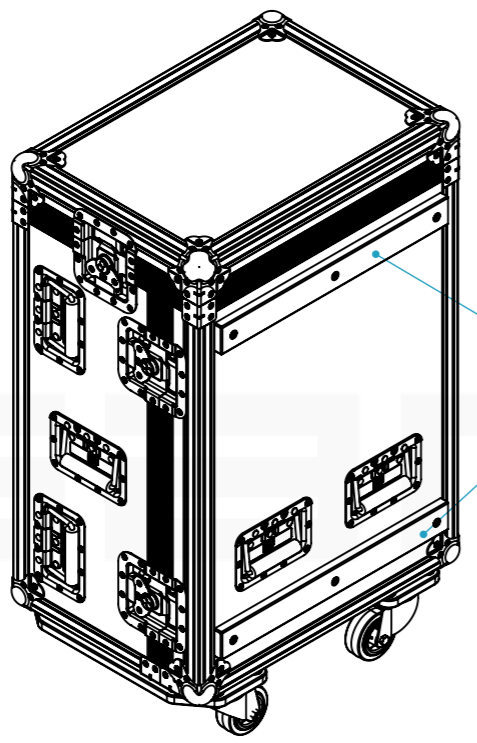
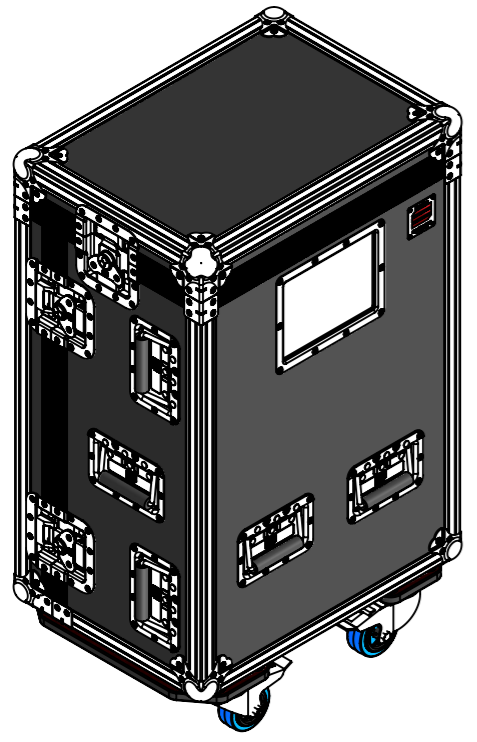
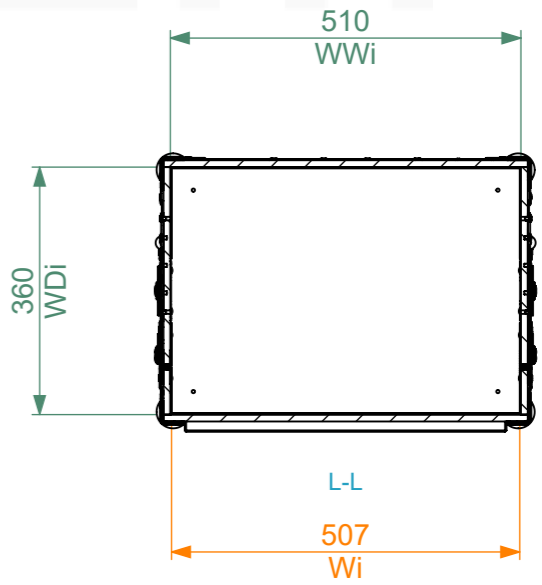
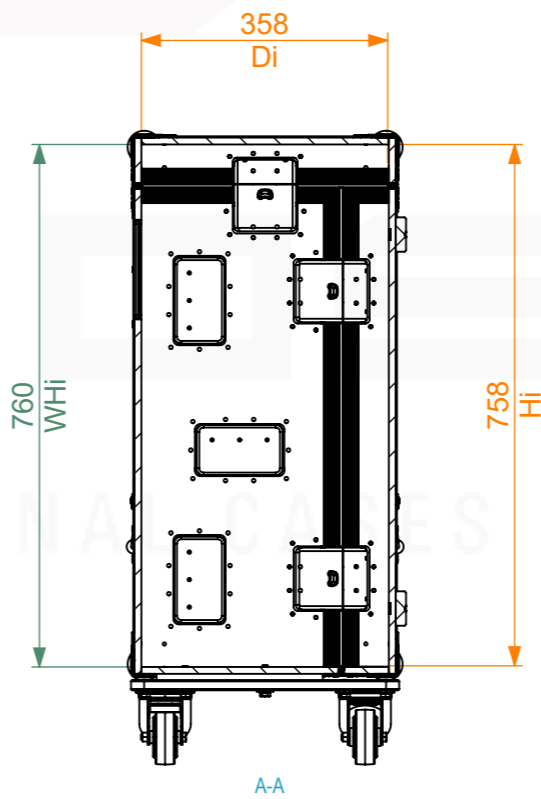
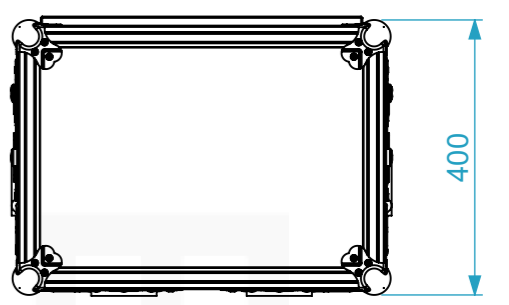
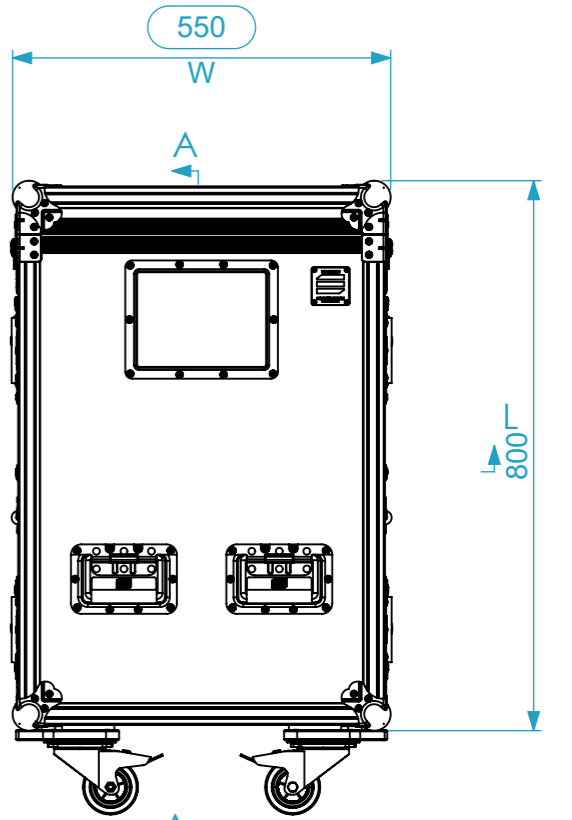
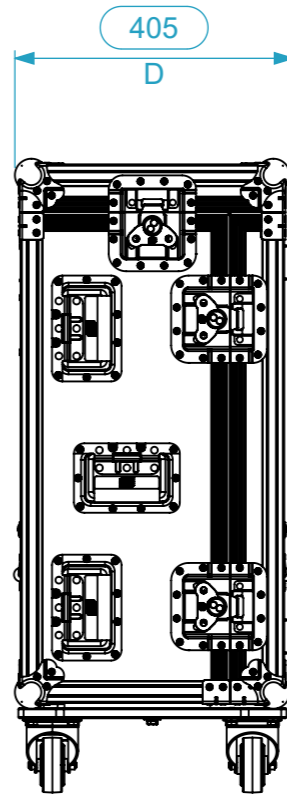
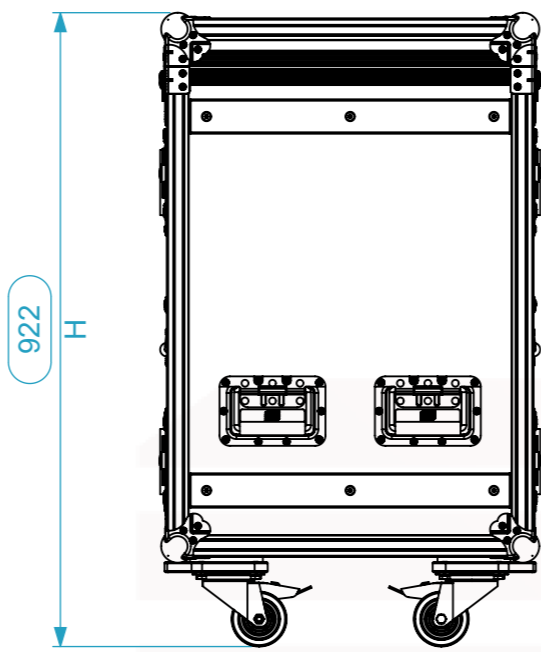

General External Dimensions	
W	Width
D	Depth
H	Height
Usable Inner Dimensions	
Wi	Inside Width
Di	Inside Depth
Hi	Inside Height
Wood Inner Dimensions	
WWi	Wood Inside Width
WDi	Wood Inside Depth
WHi	Wood Inside Height

Name	Date
CarlaSilva	11/08/2021
Reference	X13MR.0558040
Scale	1:1
units in mm	general tolerance 0.8mm
DO NOT SCALE	
Flight case X13MR. 55.80.40 (50x76x36 WID)	



This drawing must not be copied or disclosed without consent of the owner



A3