

Interior dimensions		
Width	Depth	Height
1220	1160	1442
Weight	Approx. 84 Kg	
Wall Thickness		9mm

REVISIONS				
ZONE	REV.	DESCRIPTION	DATE	APPROVED
-	-	Final Drawing	03-01-2017	Telmo Santos

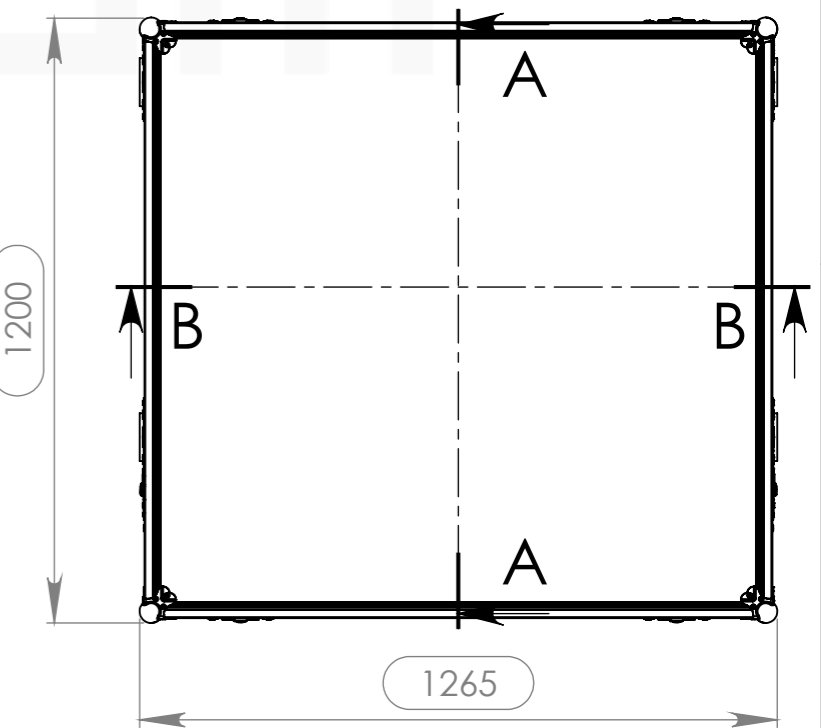
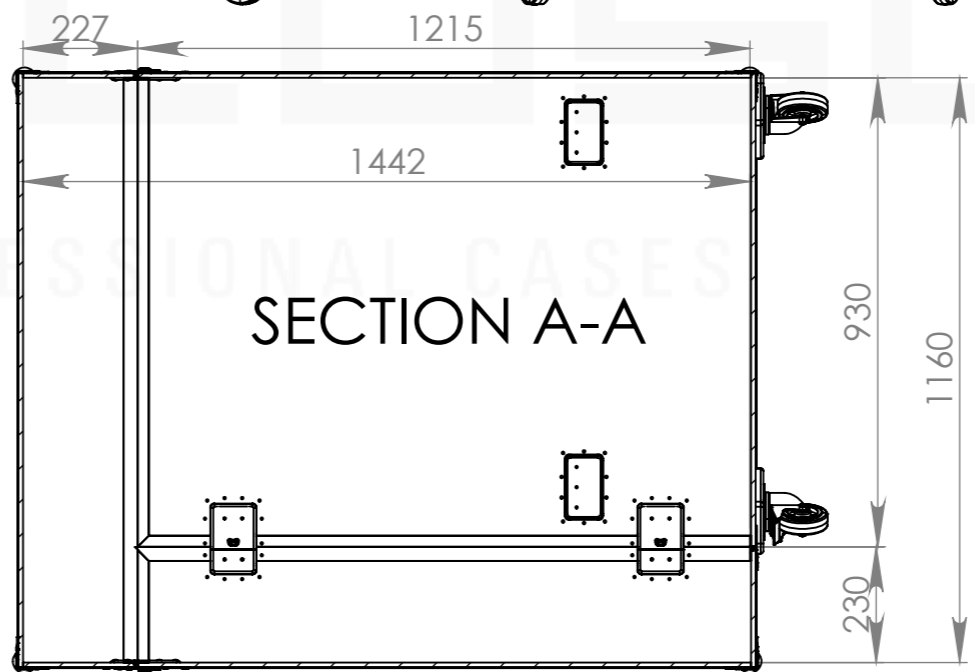
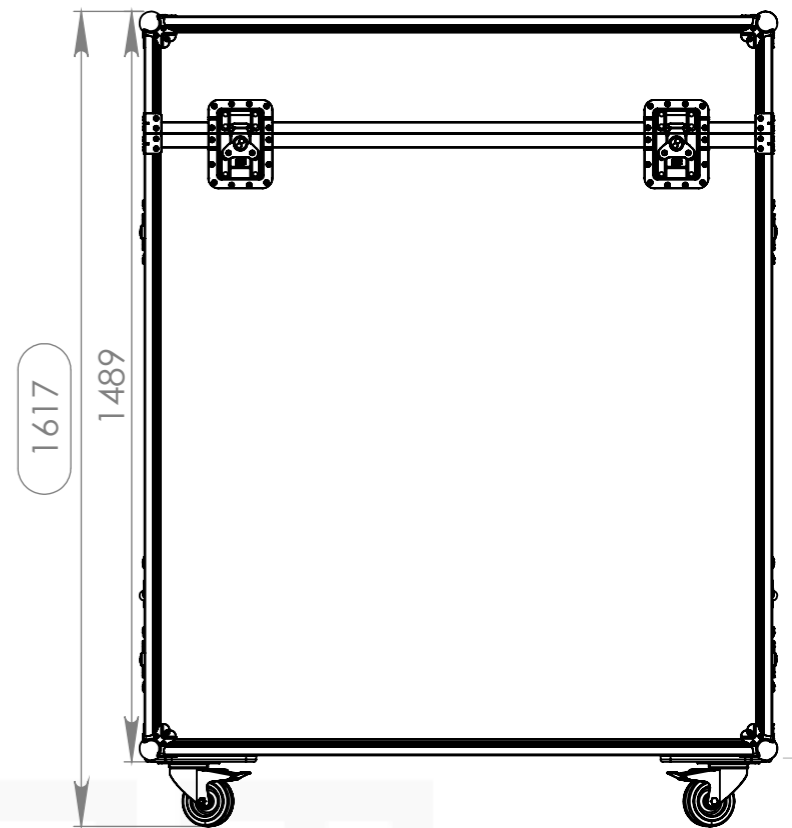
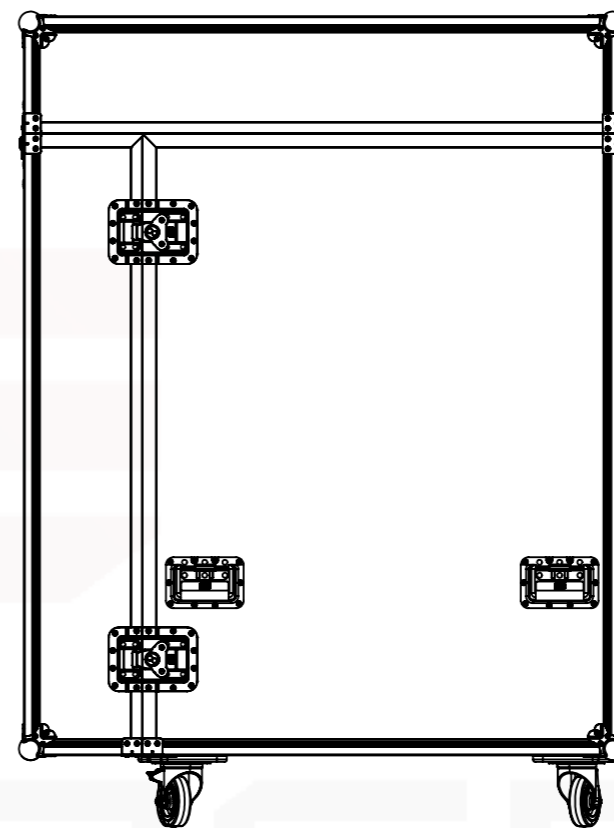
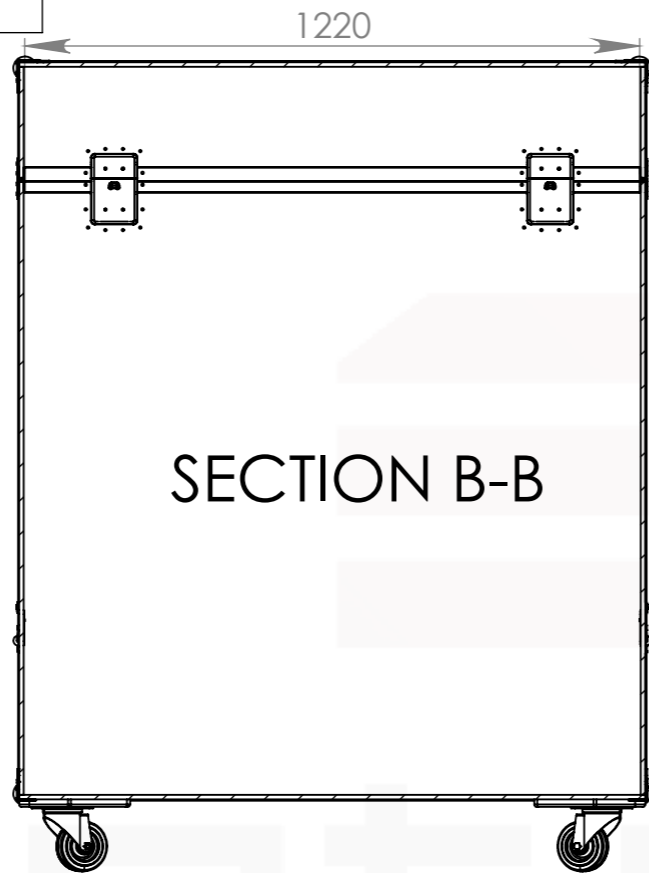
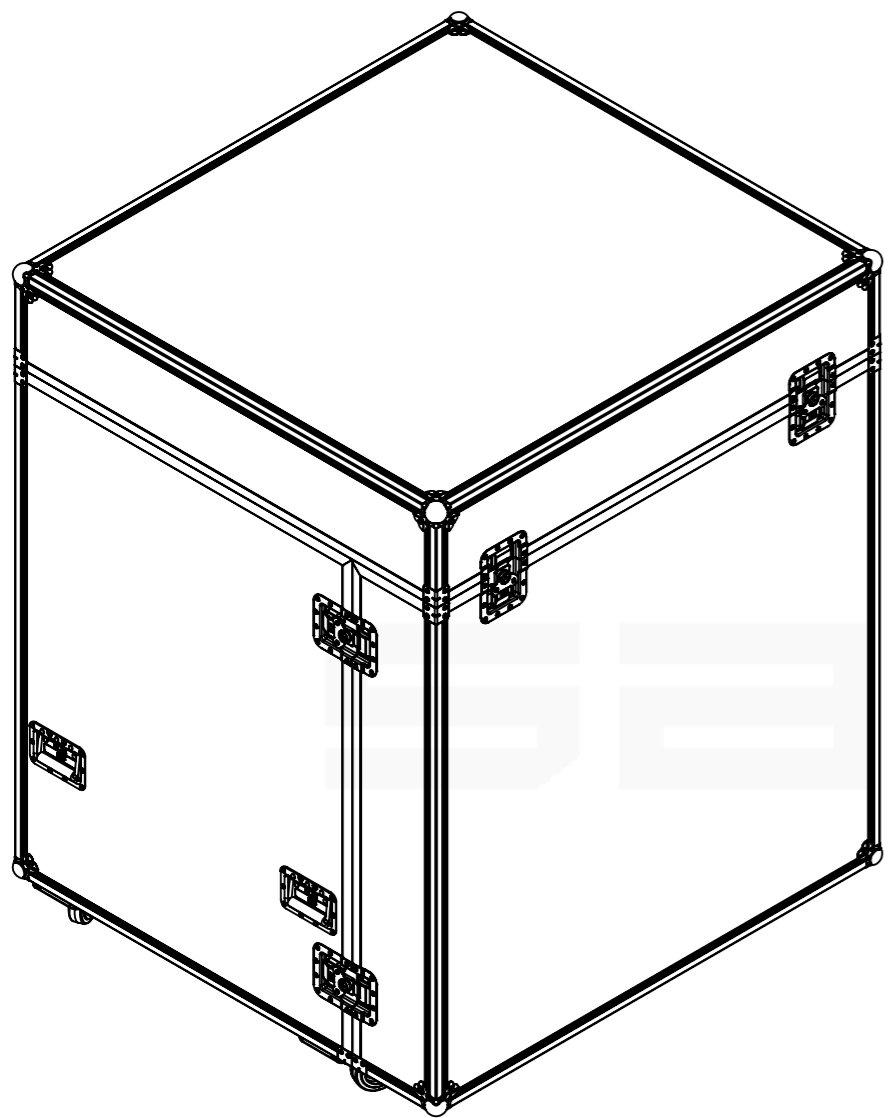

Hardware		
Qty	Ref.	Description
8	410429	Heavy Duty Ball Corner
12	40403	Large corner bracket f. 35mm case angle
4	34082	Recessed sprung handle medium model
8	172511COMP	Large AH butterfly with 'push-back', 14mm dish
2	RODA.100T	Swivel castor Ø100mm with brake
2	RODA.100	Swivel castor Ø100 mm

This drawing must not be copied or disclosed without consent of the owner

Drawn by	telmosantos	Date	04/01/2017
Reference	X13CR.1271215		
Scale	1:15	units in mm	general tolerance 0.8mm
1st Angle projection	FCSF. TAMPA SUPERIOR E FRONTAL 1220X1160X1440 MM, RODAS		

