

Internal Dimensions

Width	Depth	Height
1600	1050	1200
FC Weight	Approx. 92.99 Kg	
Wall Thickness	15mm	

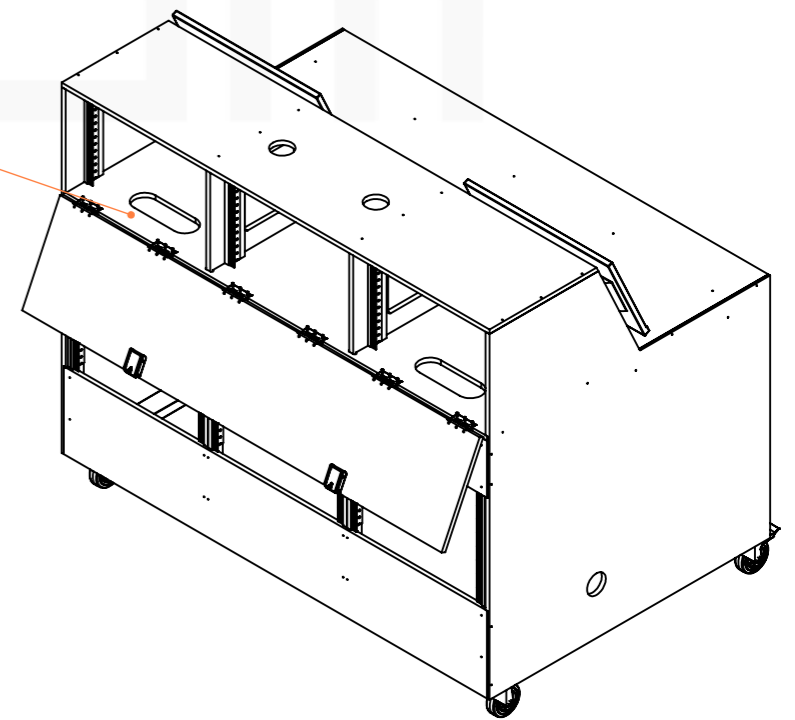

Drawn by	Name	Date
CarlaSilva	CarlaSilva	11/01/2025
Reference	WR2A.160105120	
Scale	units in mm	general tolerance
1:20	DO NOT SCALE	0.8mm
1st Angle projection	Regie de Madeira 160.105.120	

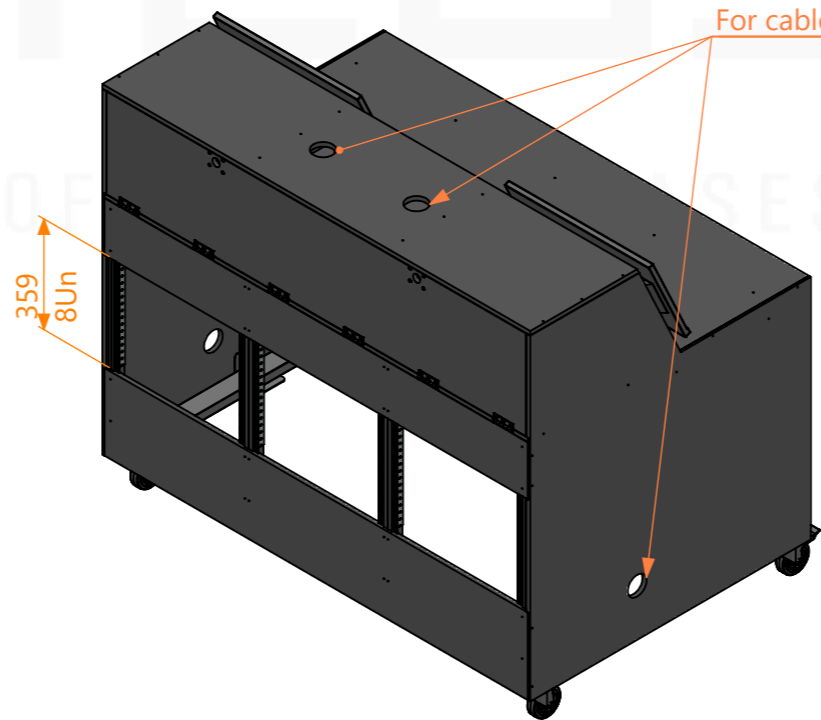
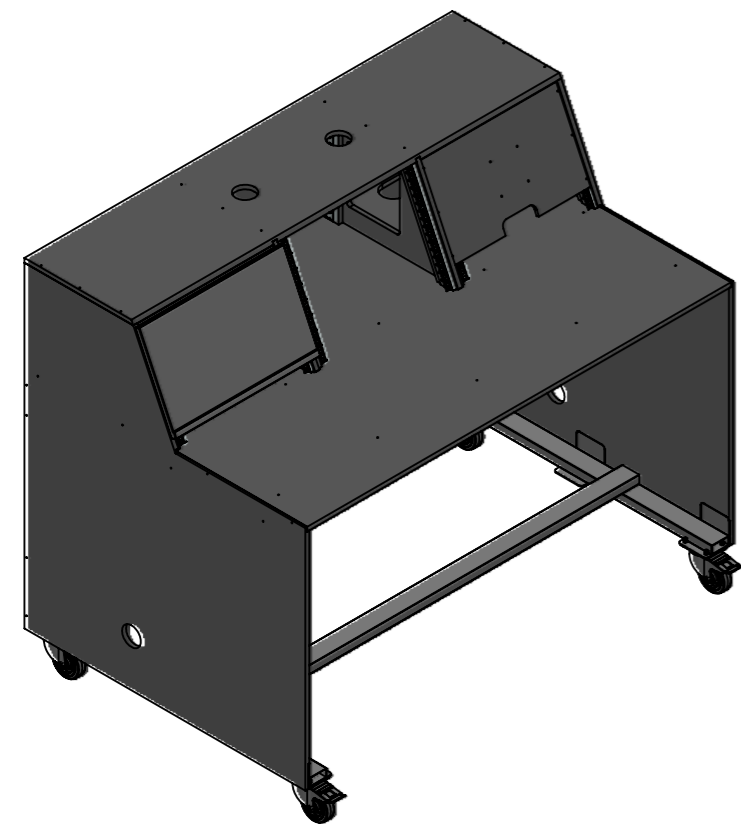
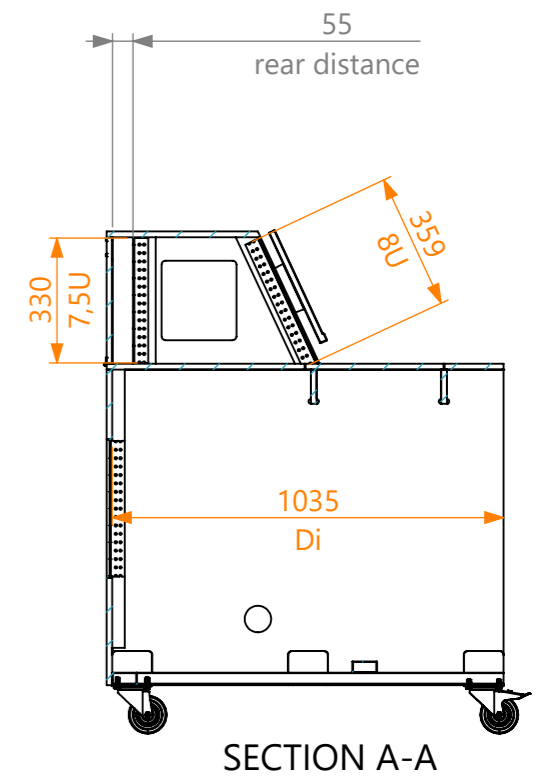
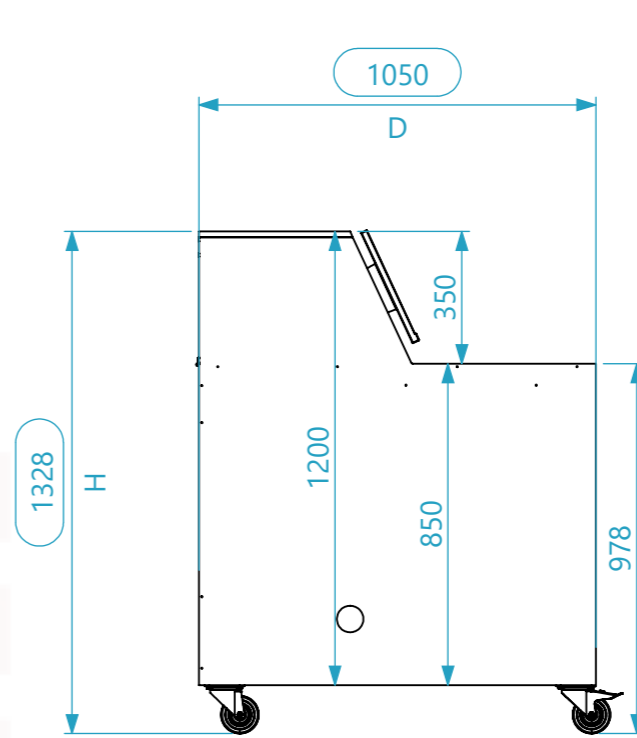
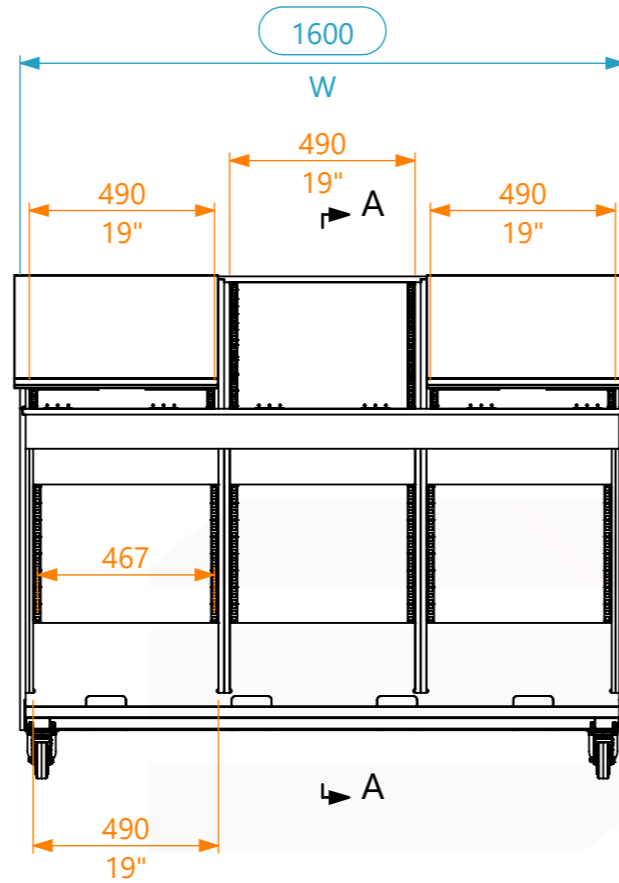
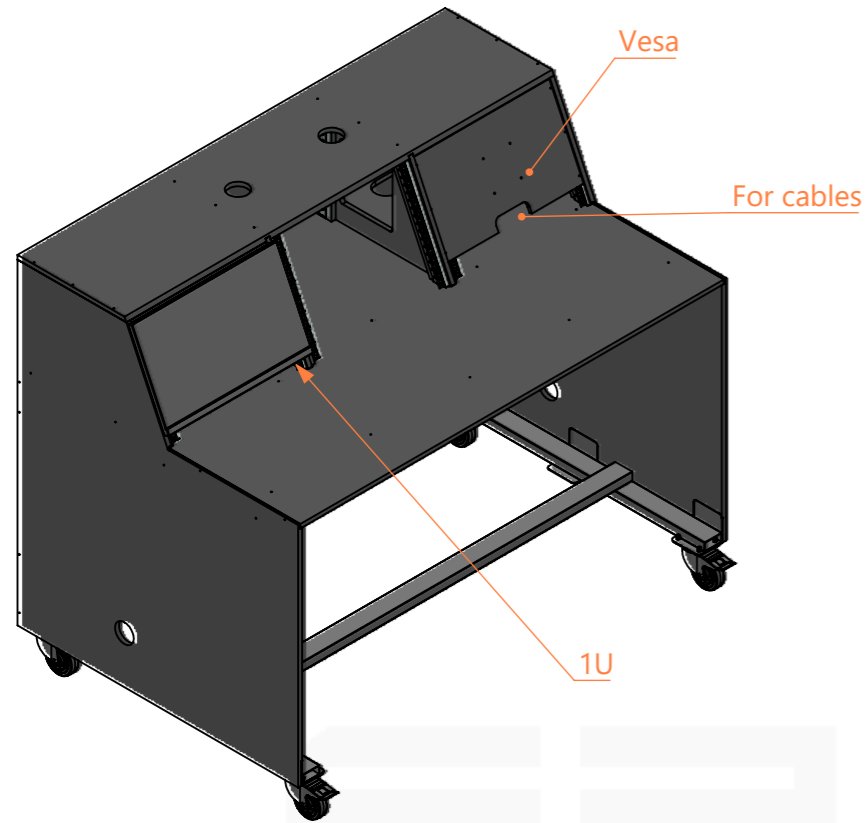

This drawing must not be copied or disclosed without consent of the owner

A3

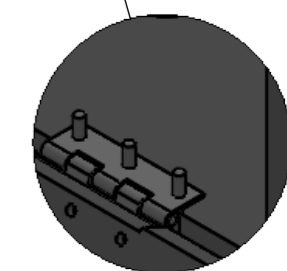
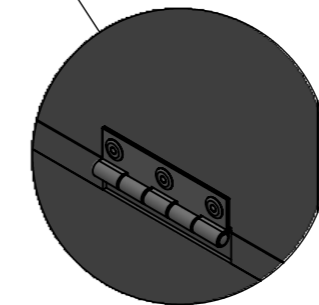
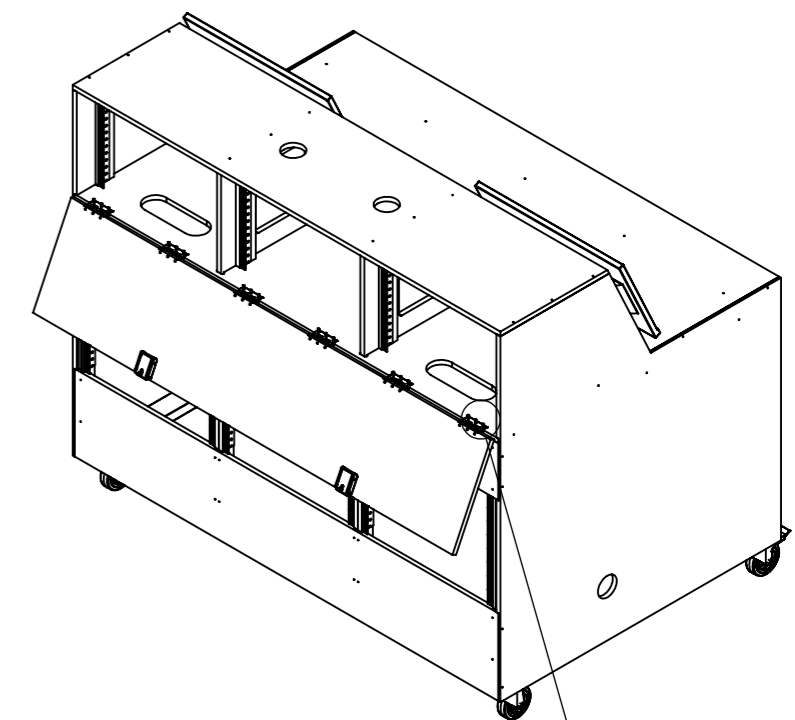
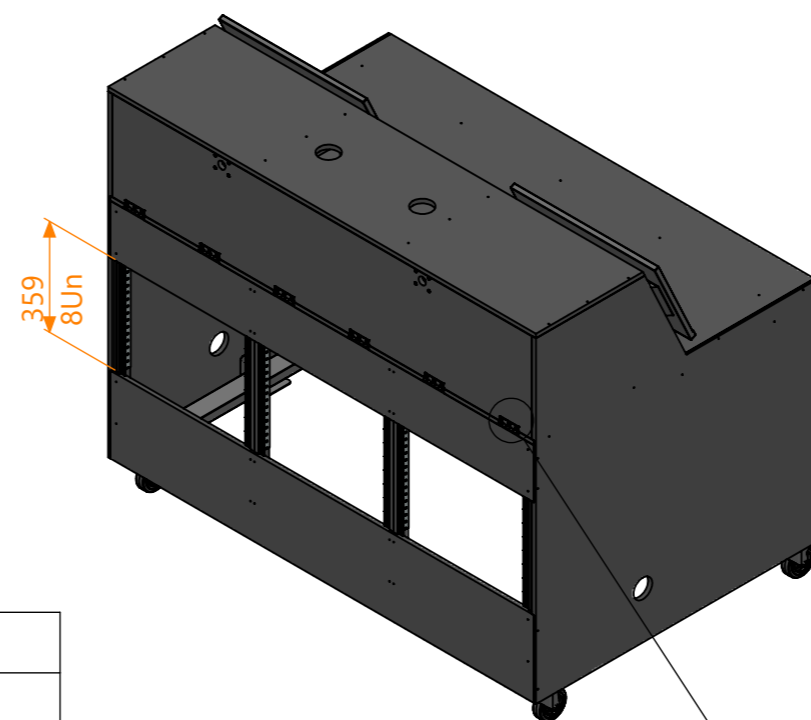
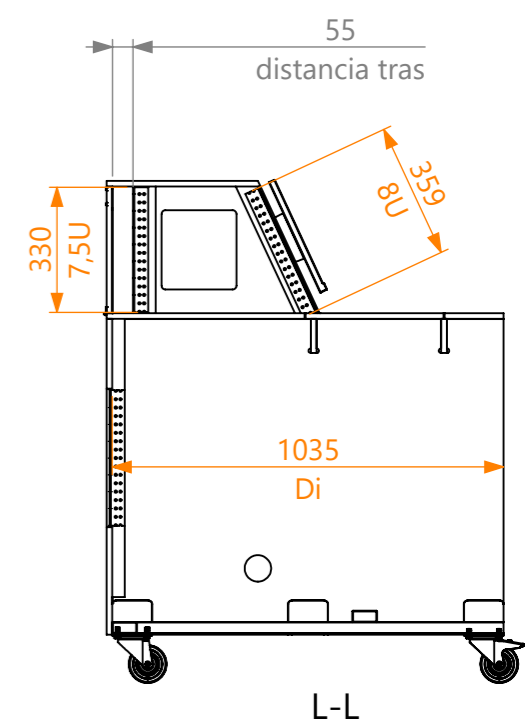
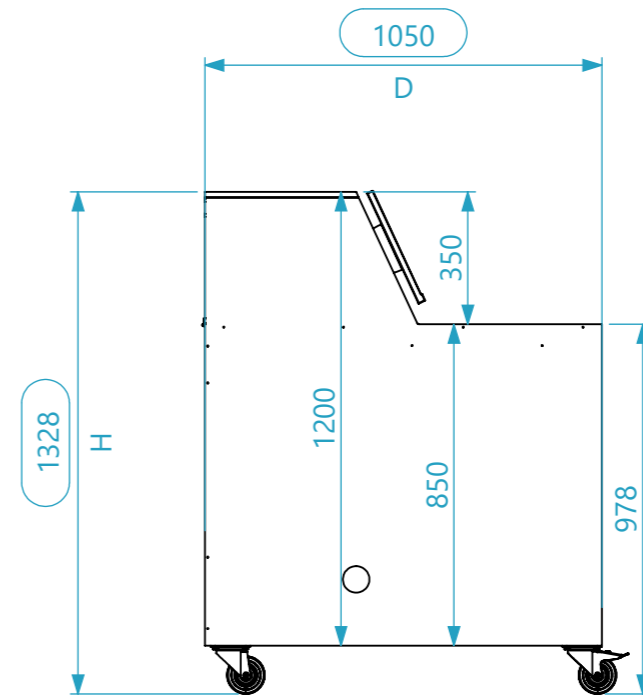
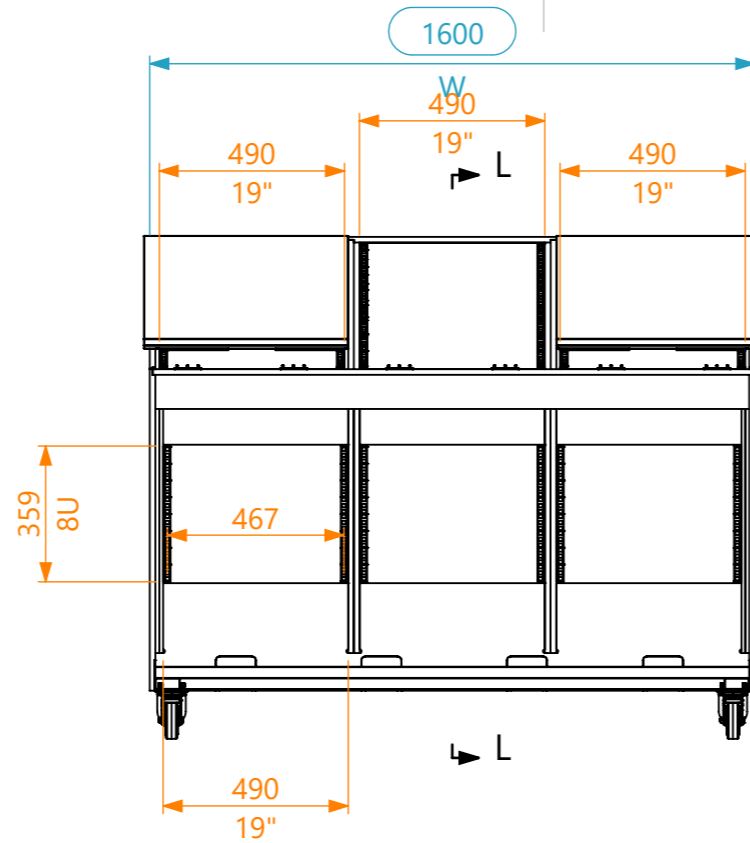
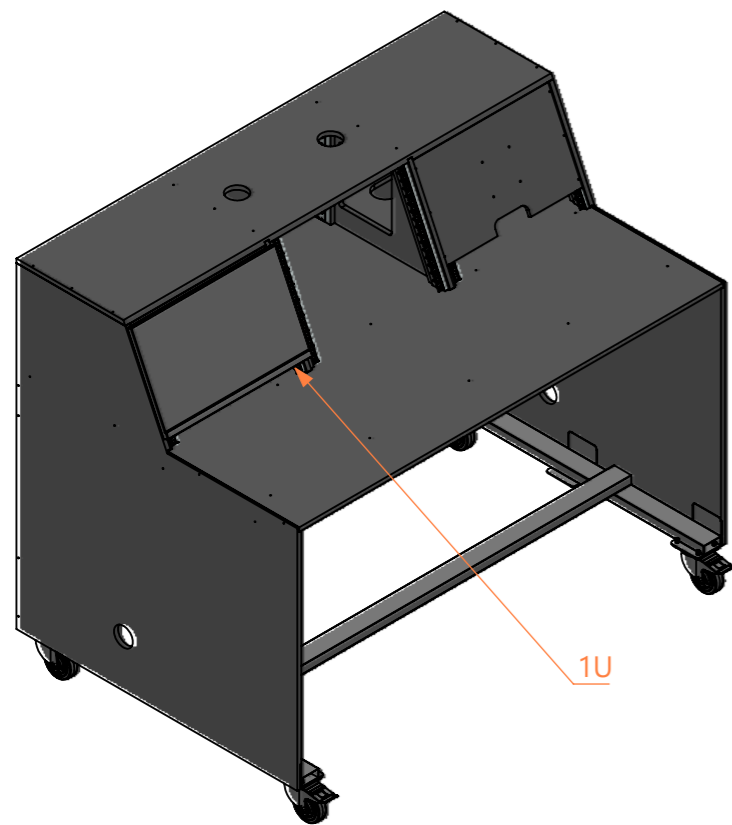

Lista de Componentes

Item nº	Quant.	Descrição	Ref.
1	2	Roda giratória Ø100mm toda preta c/ travão (Cap.100Kg)	RODA.A100TBK
2	2	Roda giratória Ø100mm azul (Cap. 100Kg) AH	RODA.A100BK
3	8	PRUMO RACK FERRO 8UN	PRUMO.1005
4	3	PRUMO RACK FERRO 7,5 UN ESQ	PRUMO.1005
5	3	PRUMO RACK FERRO 7,5 UN DIR	PRUMO.1005
6	4	PRUMO RACK FERRO 1UN	PRUMO.1005
7	2	Fecho X-BOX Mini	L2455
8	8	Rebite POP 4x16 - preto	DIN7337.0416.LP
9	6	Dobradiça de piano de 70 mm - preto	2602BLK
10	10	Chapa	

This drawing must not be copied or disclosed without consent of the owner 1st Angle projection	Drawn by	Name	Date
	Reference	CarlaSilva	11/01/2025
	Scale	WR2A.160105120	
	Scale	units in mm	general tolerance
	1:20	DO NOT SCALE	0.8mm
	Regie de Madeira 160.105.120		

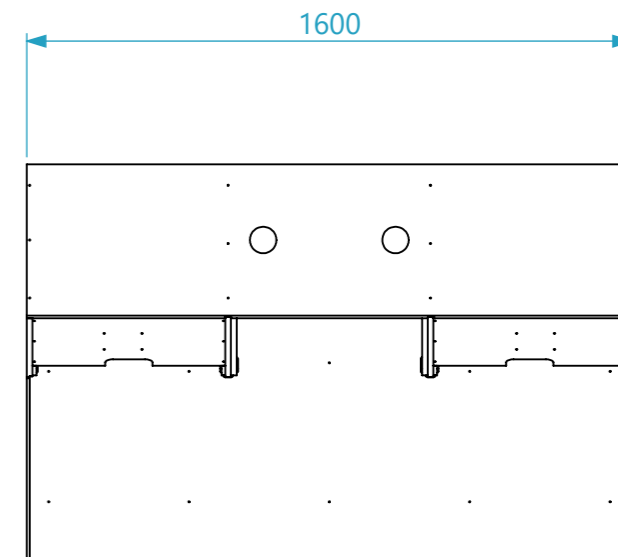
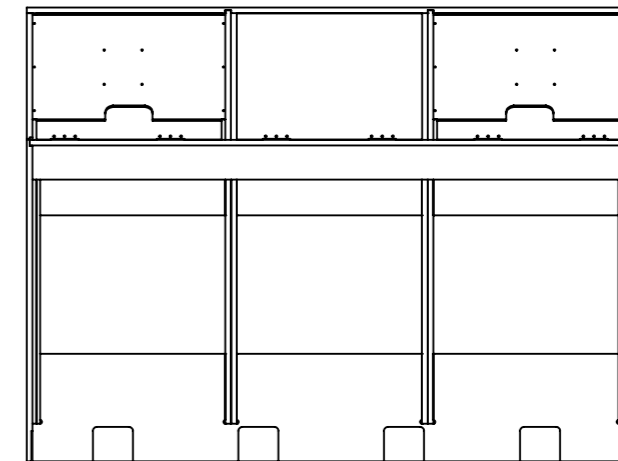
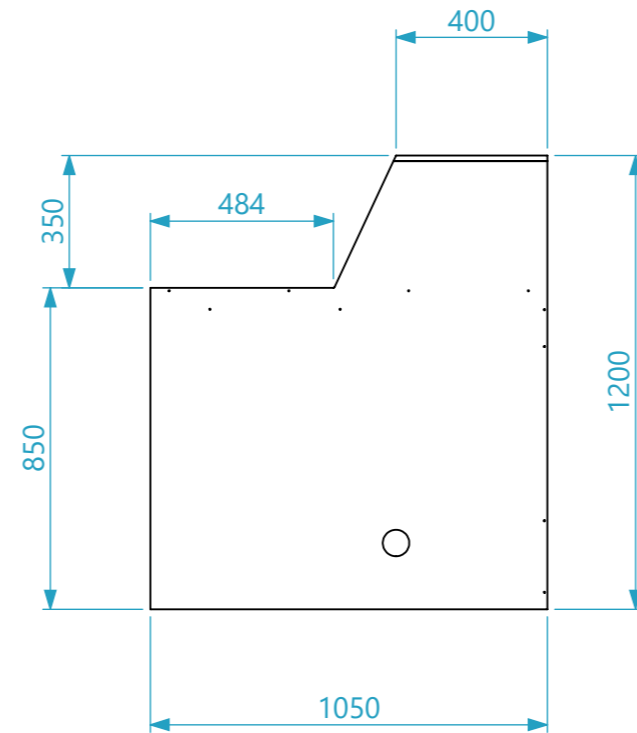
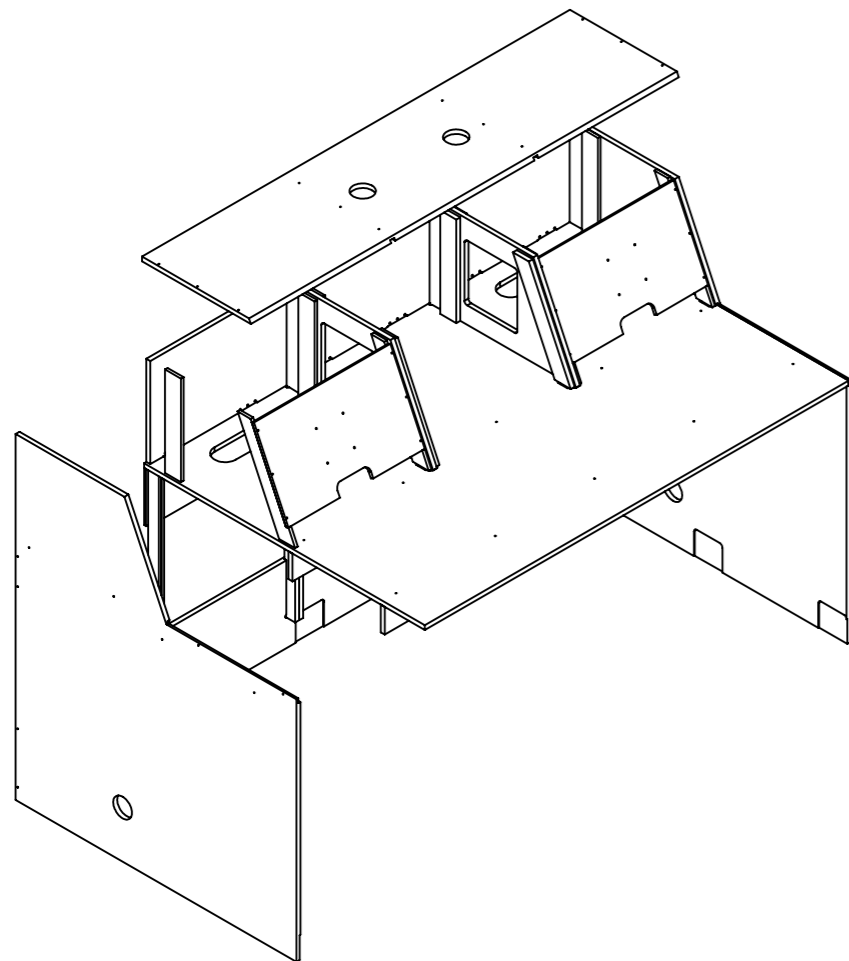

Lista de Peças

Item Nº	Descrição	Quant.	Comprimento (W)	Largura (D)	Espessura (Z)	Material
1	Cima	1	1600	406.99	15	P90 - Black
2	Lateral	1	1185	1050	15	P90 - Black
3	Lateral	1	1185	1050	15	P90 - Black
4	Mesa	1	1585	1050	15	P90 - Black
5	Tras_Cima	1	1585	185	15	P90 - Black
6	Tras_Baixo	1	1585	284	15	P90 - Black
7	Divisoria	2	547.81	350	15	P90 - Black
8	Porta	1	1569	334	15	P90 - Black
9	Calco_1	4	335	60	10	P90 - Black
10	Calco_2	2	394.99	54.38	15	P90 - Black
11	Calco_3	2	335	60	15	P90 - Black
12	Calco_4	4	394.99	54.38	10	P90 - Black
13	Tabua_Vesa	2	509.8	304.29	10	P90 - Black
14	Calcos_Baixo_1	4	736	40	15	P90 - Black
15	Calcos_Baixo_2	4	736	40	10	P90 - Black
16	Reguas_Reforco(CM)	2	1585	90.4	15	COF - COF BROWN

This drawing must not be copied or disclosed without consent of the owner	Drawn by CarlaSilva	Name CarlaSilva	Date 11/01/2025
	Reference WR2A.160105120	Scale 1:20	
	units in mm DO NOT SCALE	general tolerance 0.8mm	Regie de Madeira 160.105.120

1st Angle projection

santosom
PROFISSIONAL CARPES

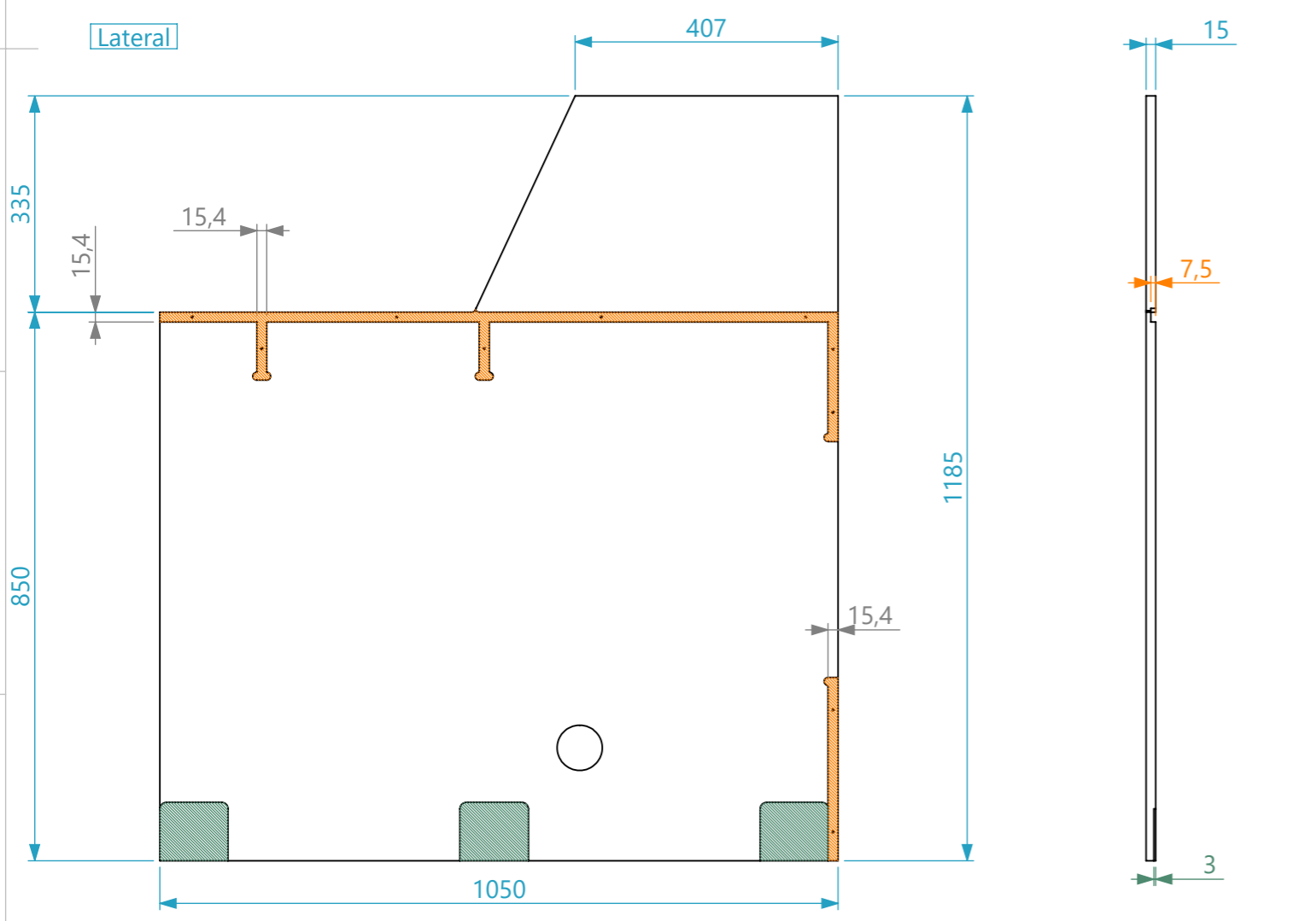
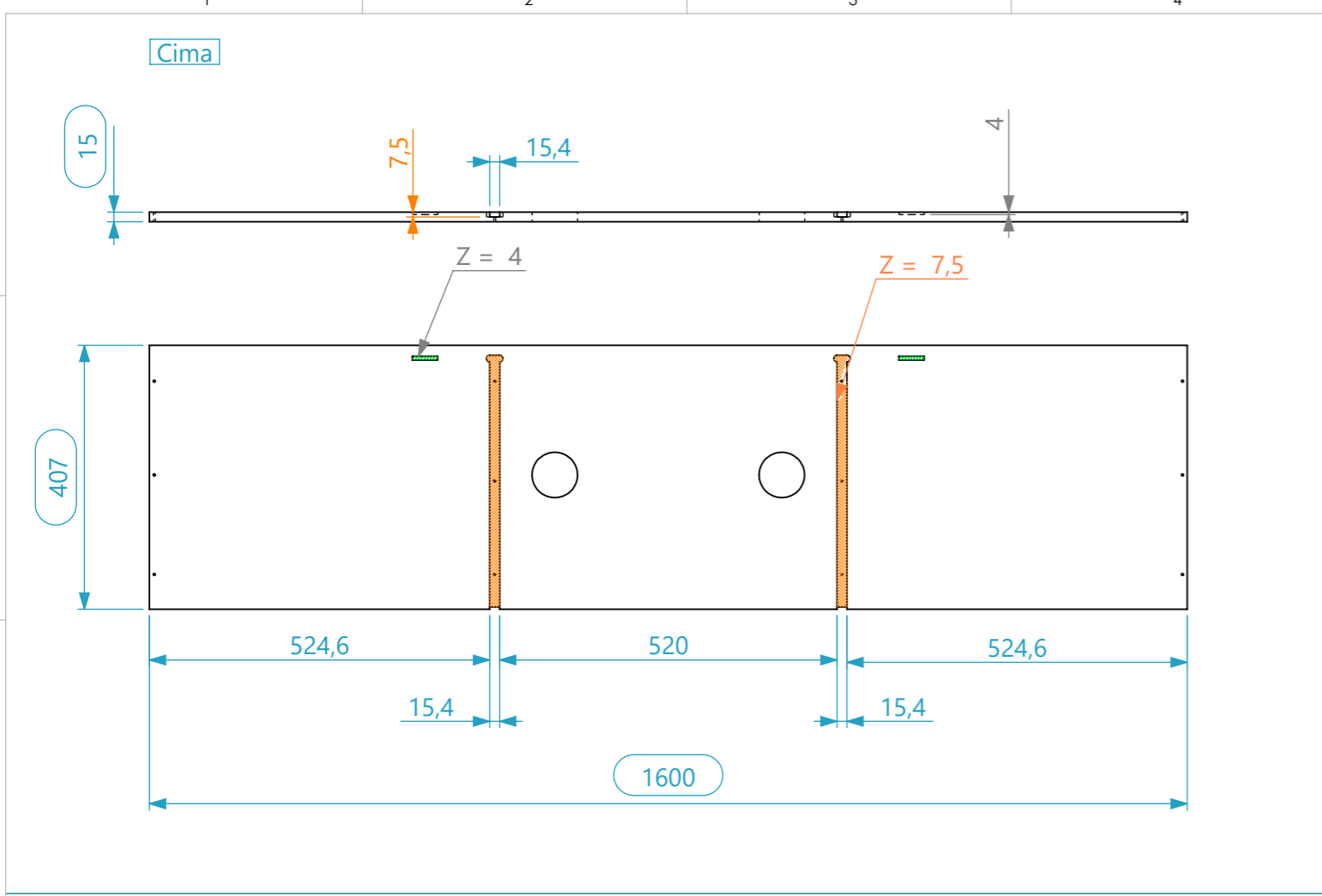

AS LATERAIS SÃO SIMÉTRICAS

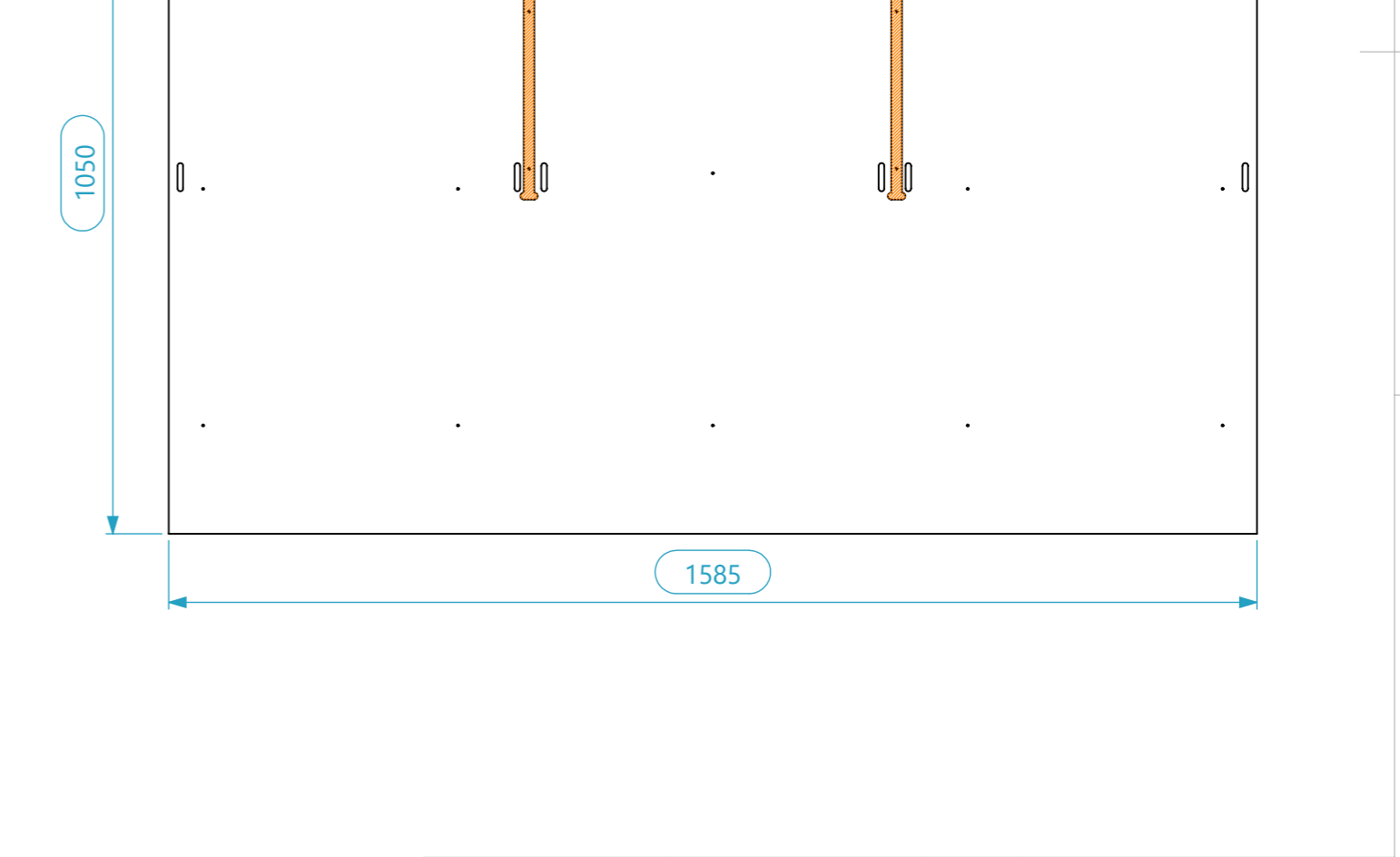
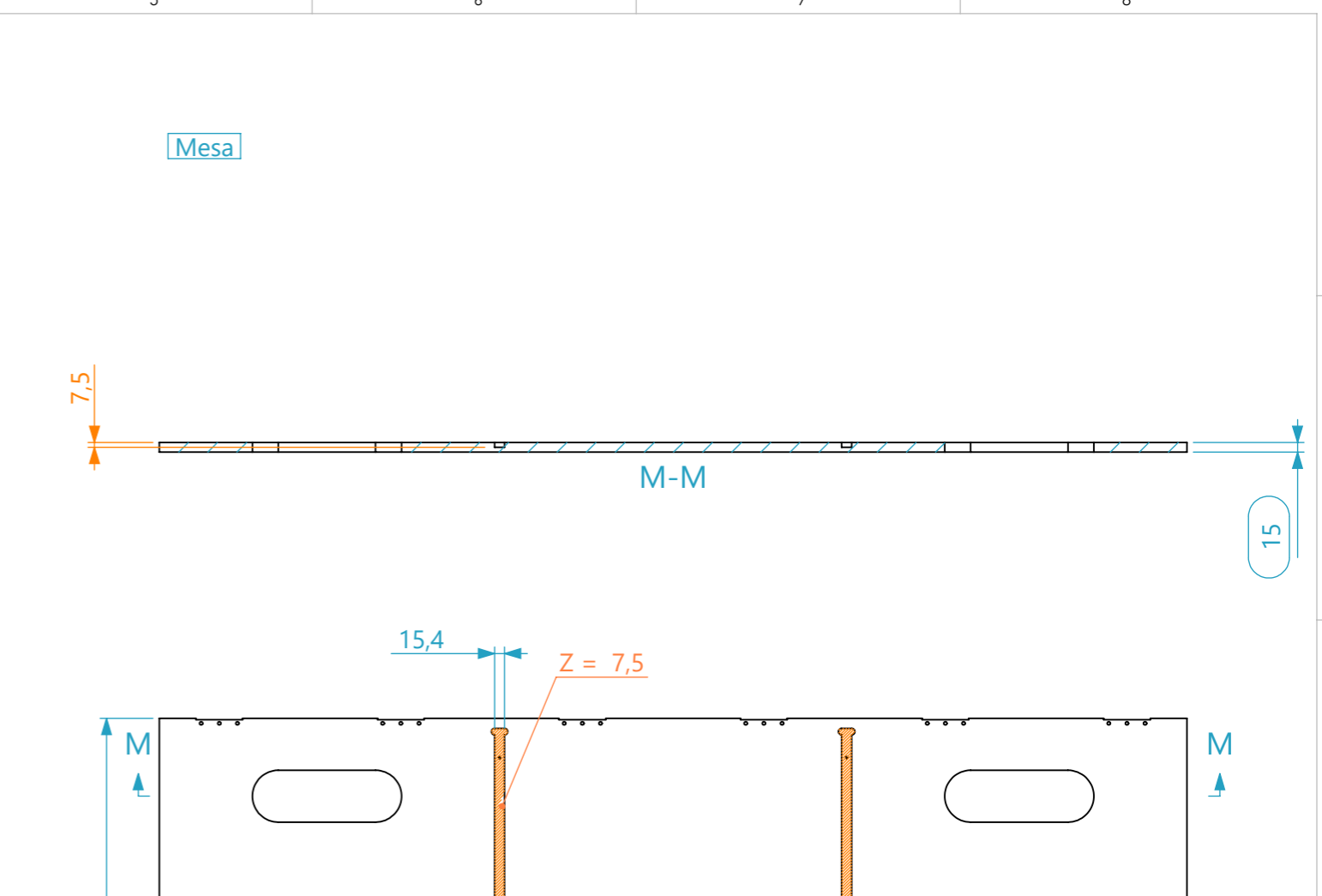

This drawing must not be copied or disclosed without consent of the owner	Drawn by CarlaSilva	Name CarlaSilva	Date 11/01/2025
	Reference WR2A.160105120	Scale 1:10	
	units in mm DO NOT SCALE	general tolerance 0,8mm	Regie de Madeira 160.105.120



santosom
PROFISSIONAL CARPES

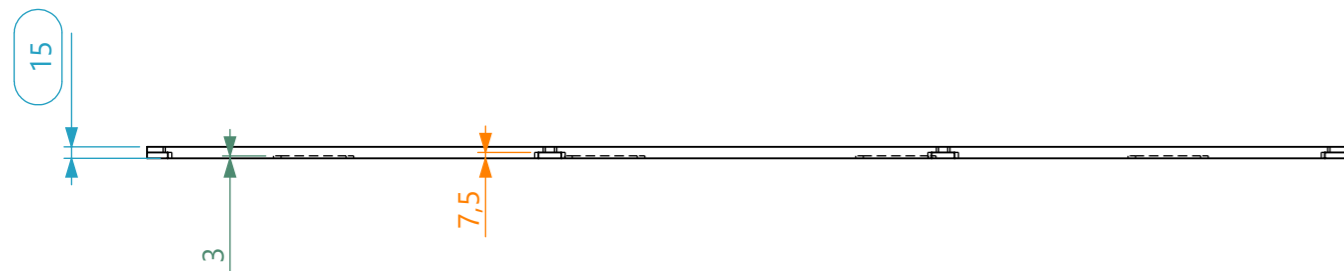
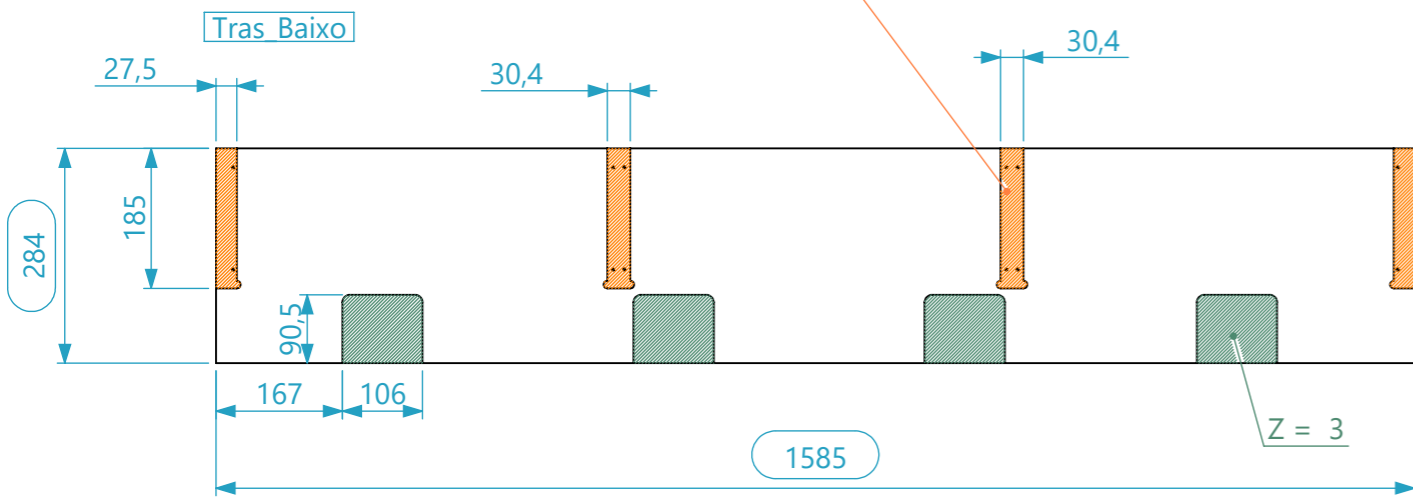
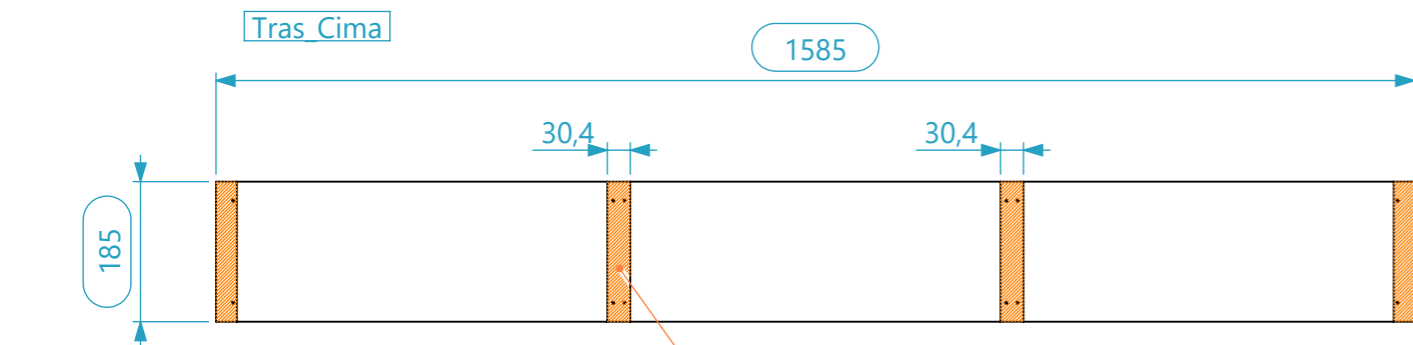

Divisoria x2

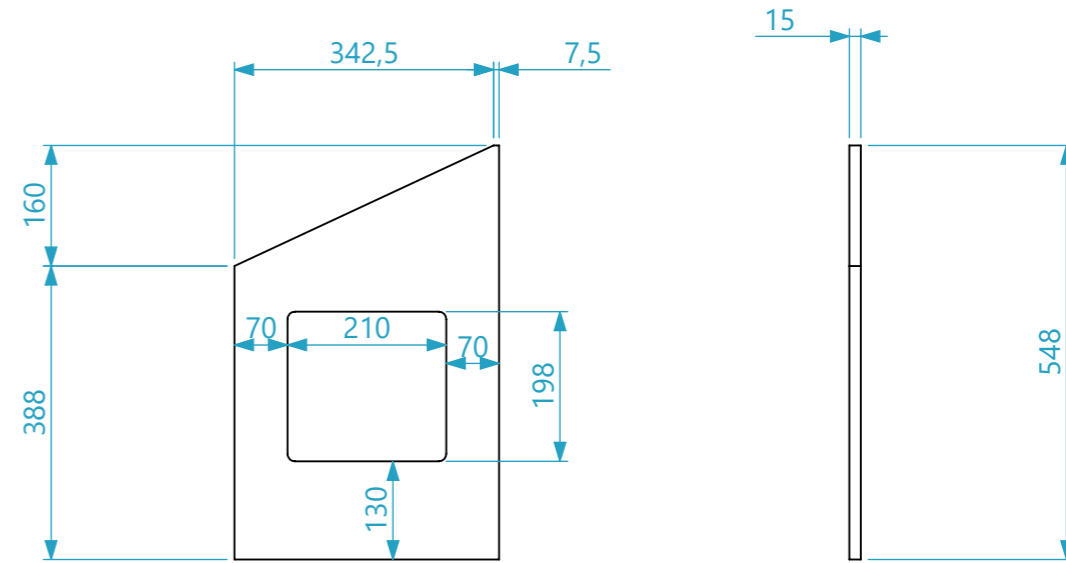

Porta

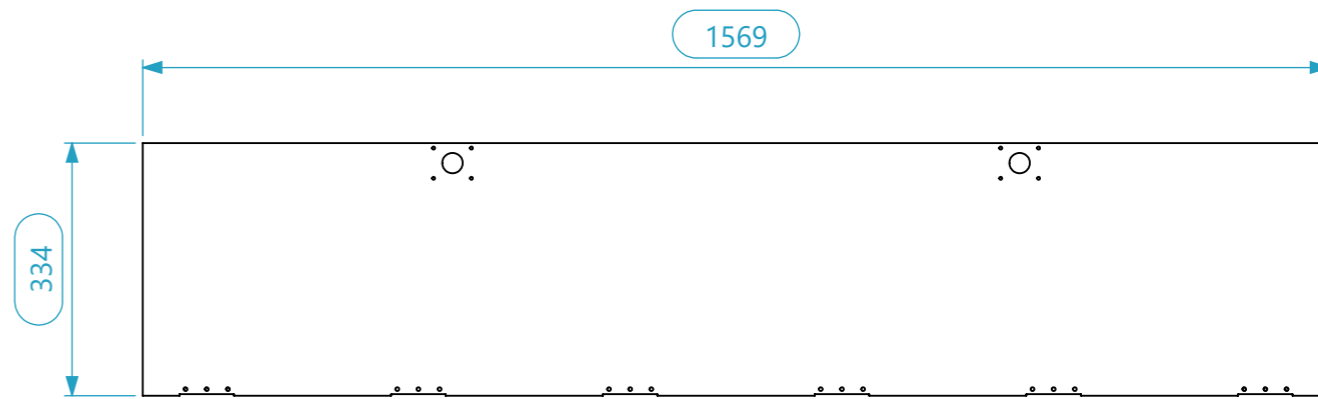

This drawing must not be copied or disclosed without consent of the owner	Drawn by	Name	Date
	Reference	CarlaSilva	11/01/2025
1st Angle projection	Scale	units in mm	
	1:10	DO NOT SCALE	
Regie de Madeira 160.105.120		general tolerance	0,8mm



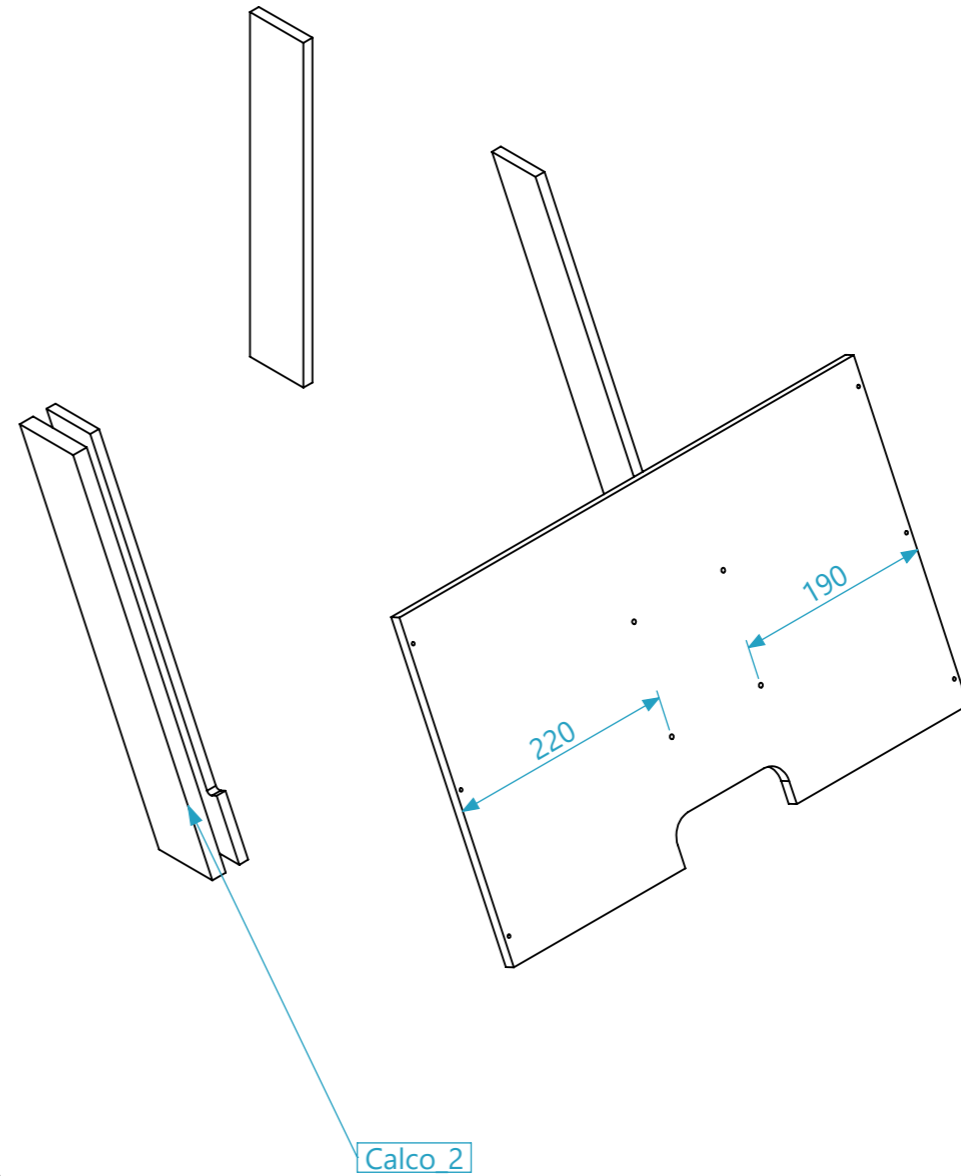
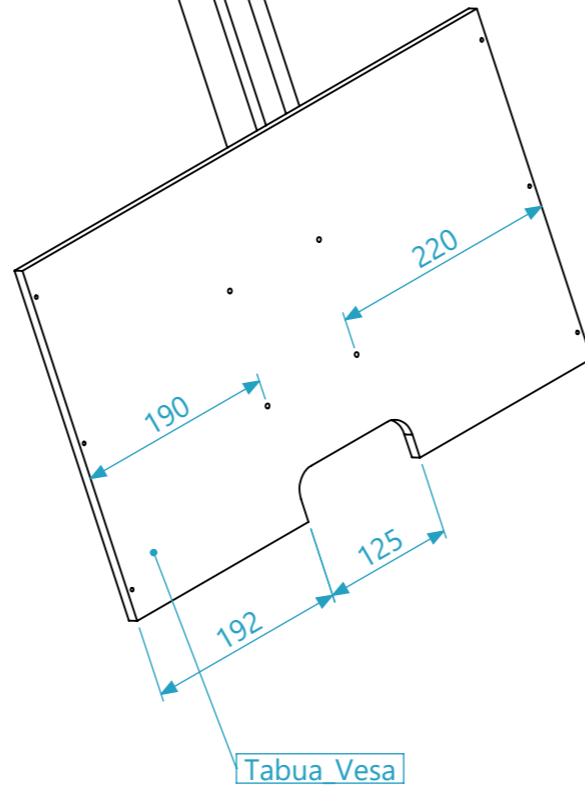
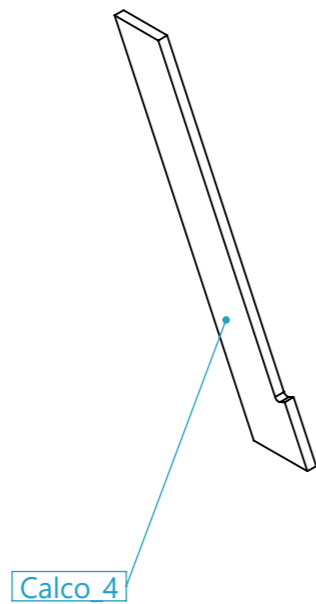
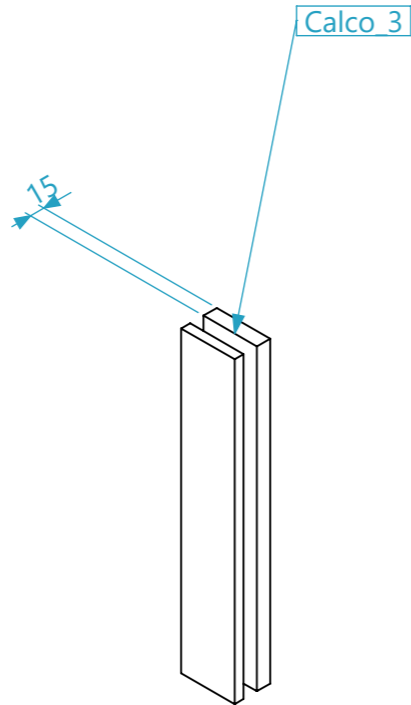
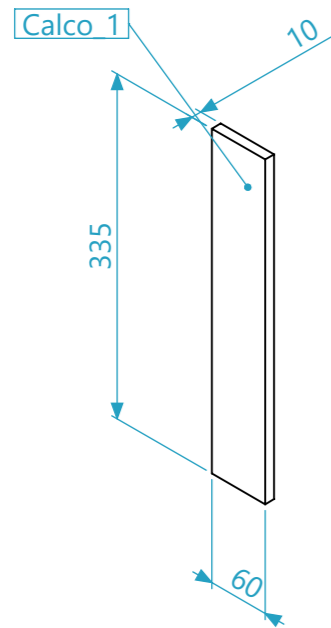

ATENÇÃO À POSIÇÃO DAS TÁBUAS VESA

This drawing must not be copied or disclosed without consent of the owner	Drawn by	Name	Date	 santosom PROFESSIONAL CARPENTRY
	Reference	CarlaSilva	11/01/2025	
	Scale	WR2A.160105120		
1st Angle projection	1:6	units in mm DO NOT SCALE	general tolerance 0.8mm	
		Regie de Madeira 160.105.120		

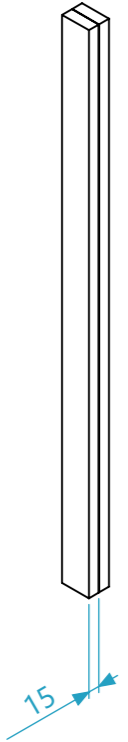
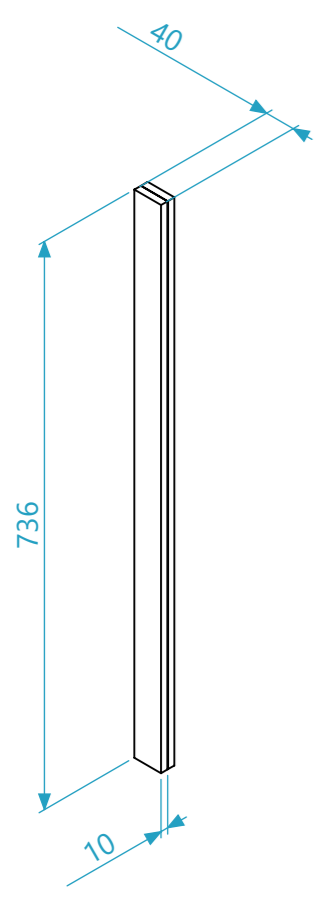

Calcos Baixo 1

Calcos Baixo 2

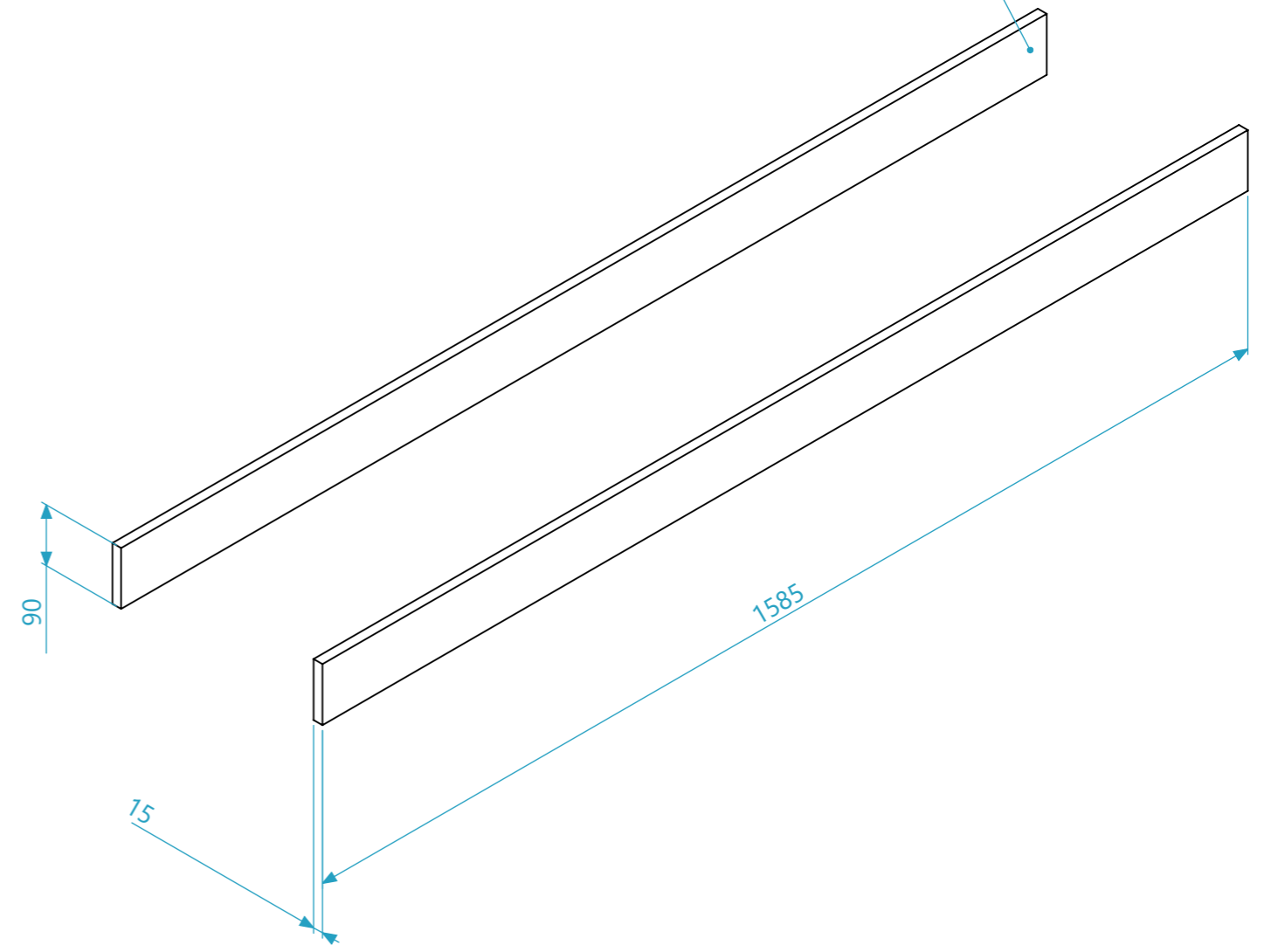
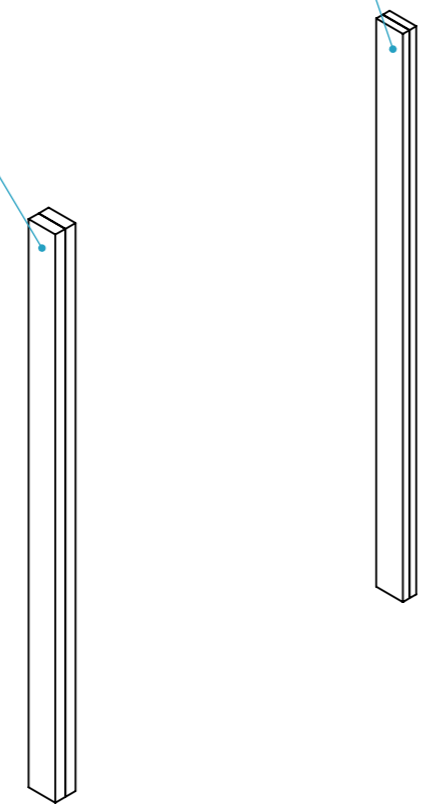

This drawing must not be copied or disclosed without consent of the owner	Drawn by	Name	Date
	Reference	Scale	units in mm
1st Angle projection	Scale	units in mm	general tolerance
	1:8	DO NOT SCALE	0.8mm
Regie de Madeira 160.105.120			



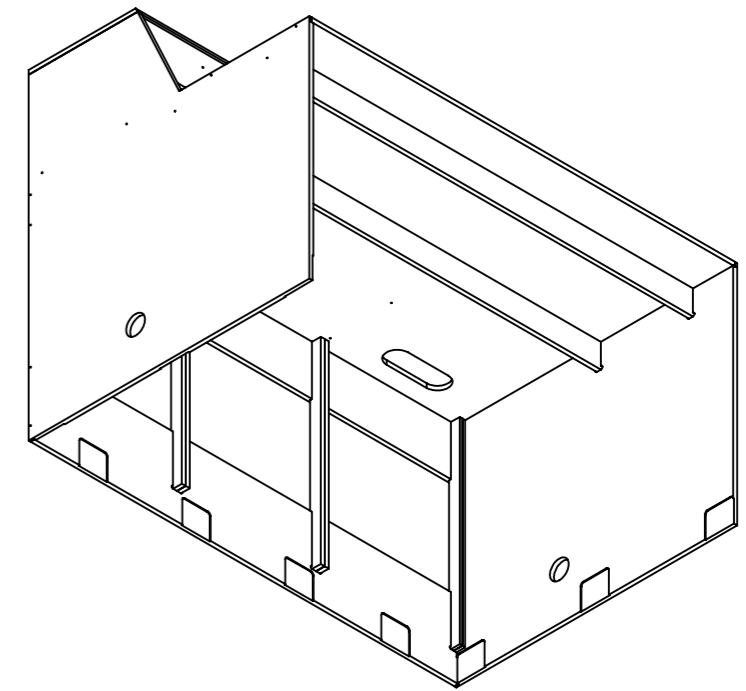
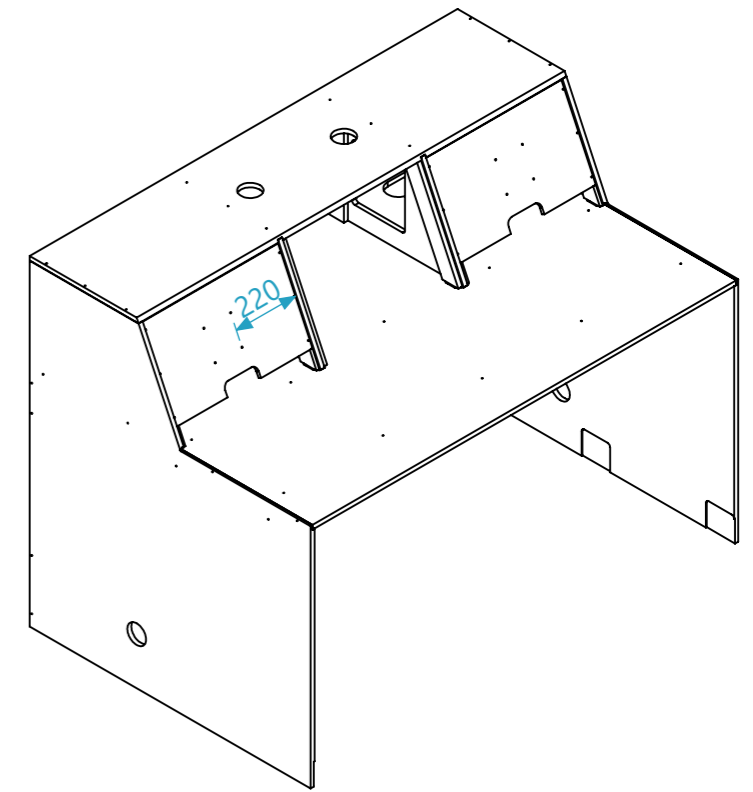
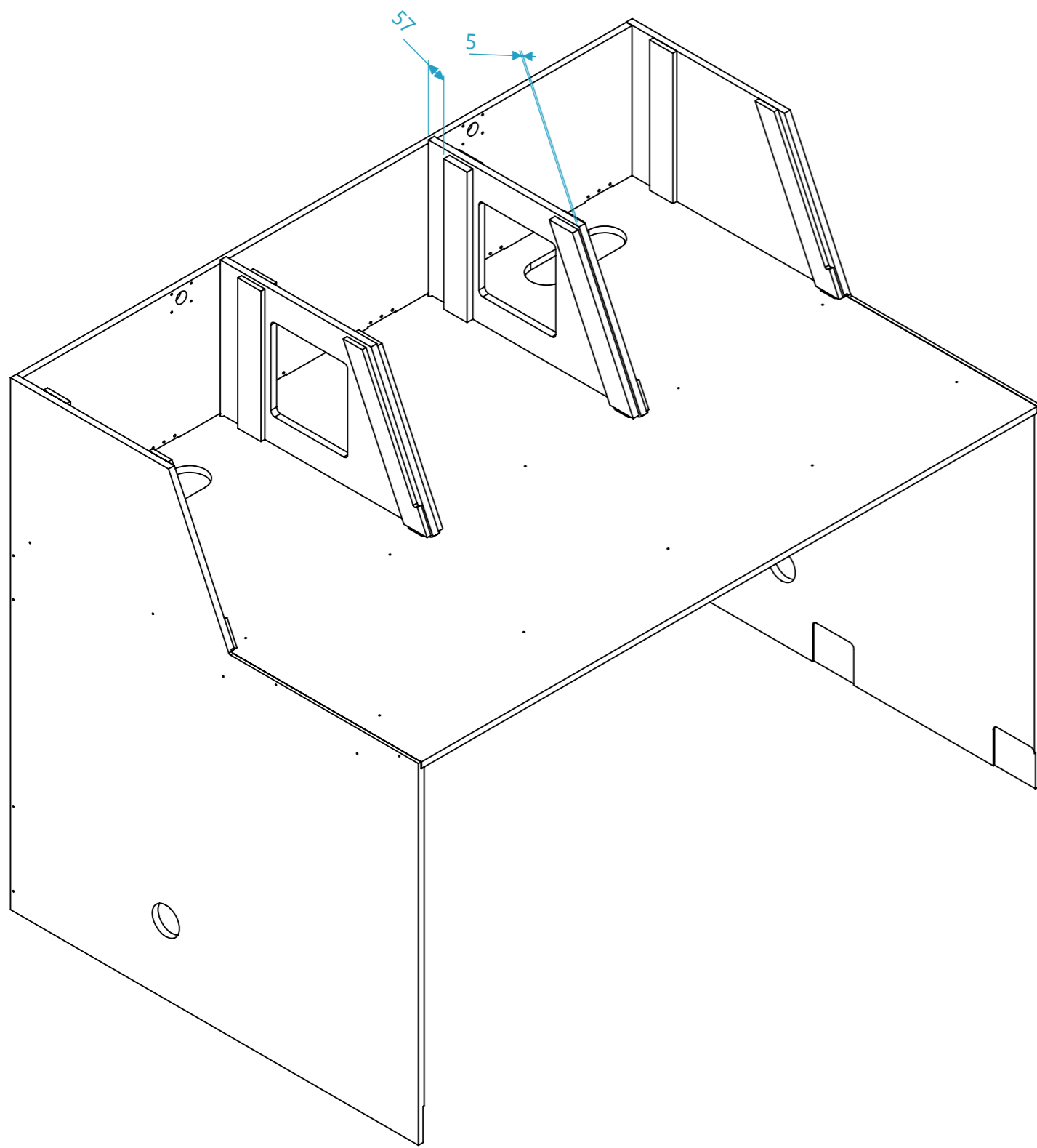

<p>This drawing must not be copied or disclosed without consent of the owner</p>	<p>1st Angle projection</p>	<p>Scale 1:10</p>	<p>units in mm DO NOT SCALE</p>	<p>general tolerance 0.8mm</p>	 santosom PROFESIONALI CARPA
	<p>Reference</p>	<p>Drawn by</p>	<p>Name</p>	<p>Date</p>	
	<p>Regie de Madeira 160.105.120</p>	<p>CarlaSilva</p>	<p>WR2A.160105120</p>	<p>11/01/2025</p>	

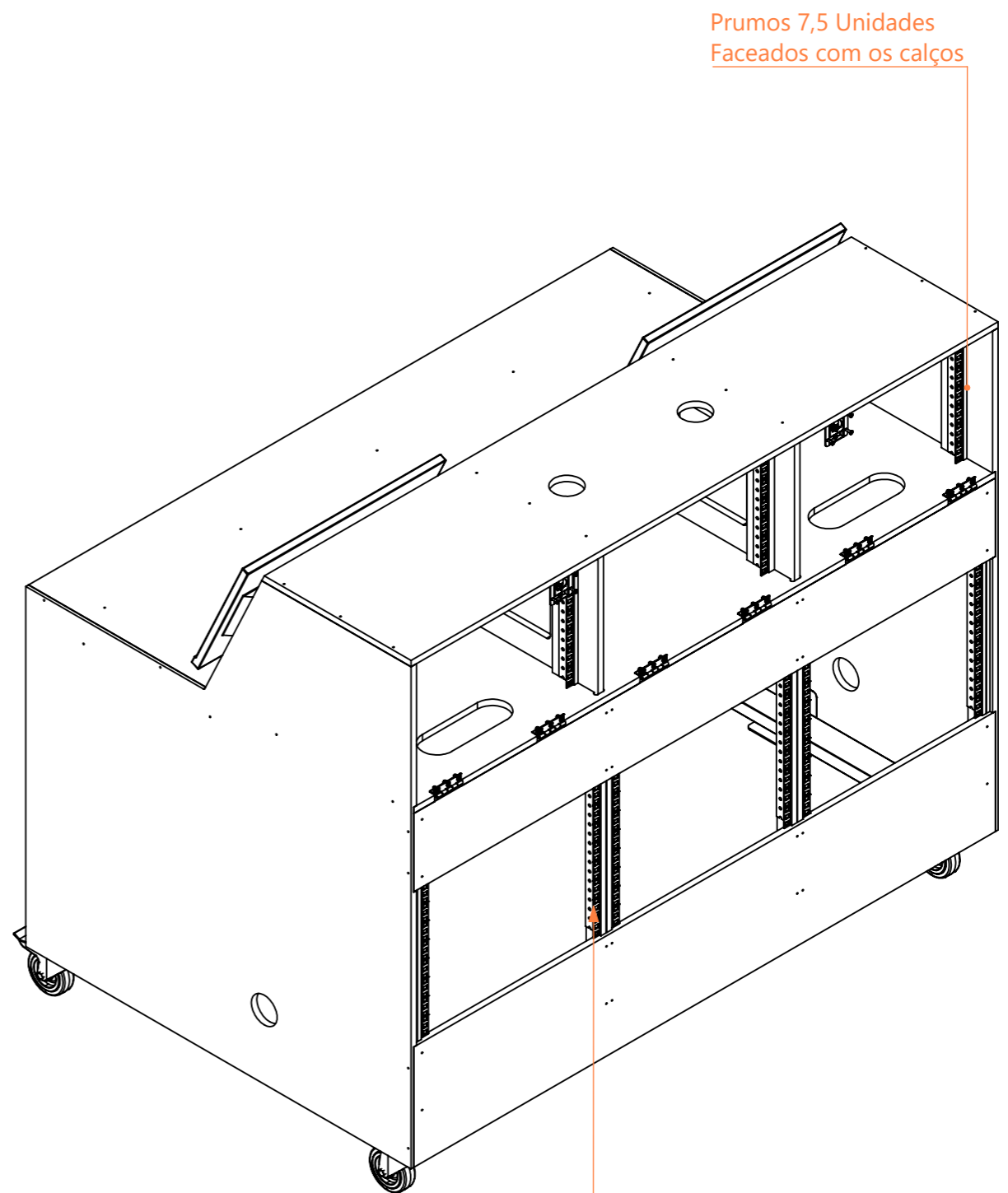
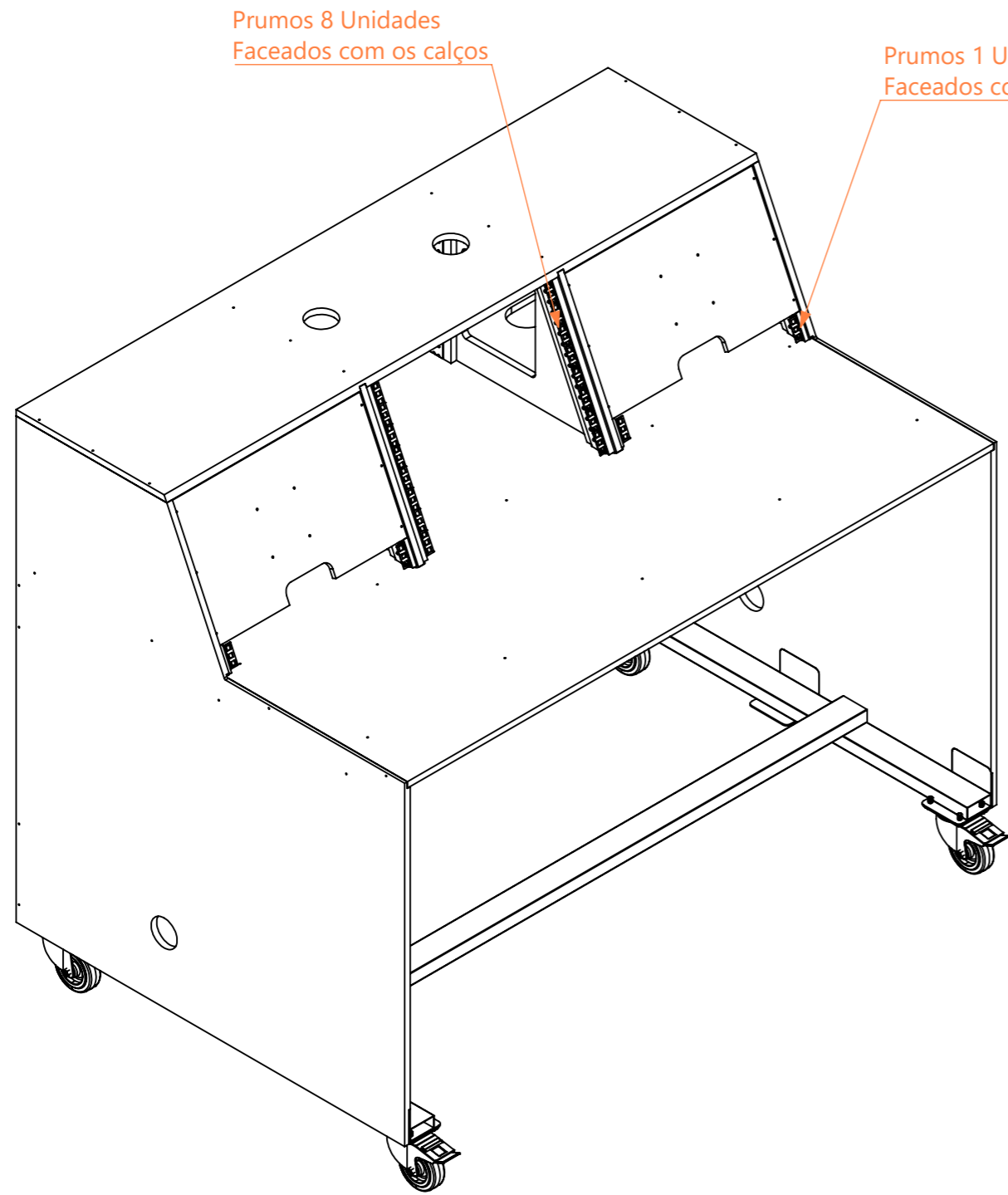

This drawing must not be copied or disclosed without consent of the owner	Drawn by	Name	Date
	Reference	CarlaSilva	11/01/2025
		WR2A.160105120	
1st Angle projection	Scale	units in mm	general tolerance
	1:12	DO NOT SCALE	0.8mm
	Regie de Madeira 160.105.120		

