

Internal Dimensions		
Width	Depth	Height
2 x 19"	139	13 UN
Weight	Approx. 57 Kg	
Wall Thickness	10mm	

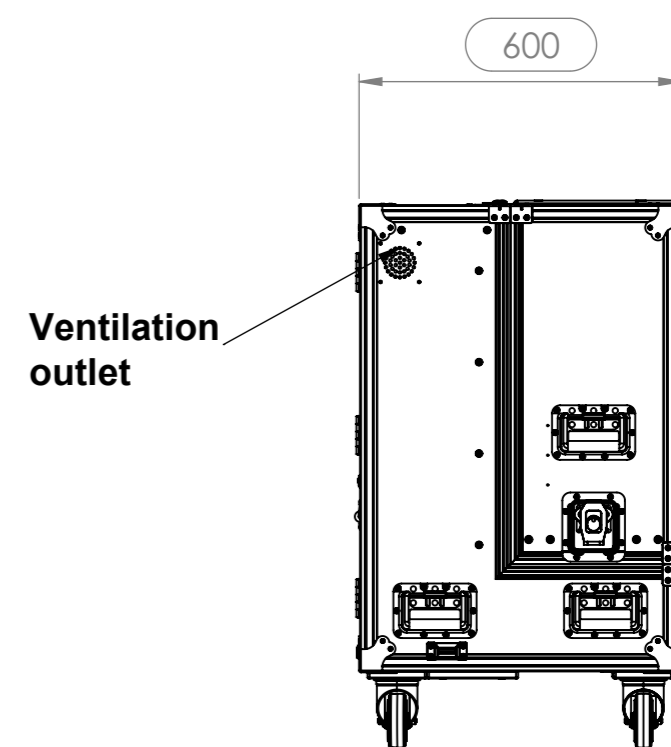

Hardware		
Qty	Ref.	Description
8	4150	Case corner three-leg
4	172531	Large butterfly V3 with 'push-back' function
2	16540	Sliding Latch System - Sliding Latch
2	8762.01	Fan - cast chassis 80x80x25 mm
10	34082	Recessed Sprung Handle Medium
8	40403	Large corner bracket f. 35mm case angle
2	RODA.100T	Swivel castor Ø100mm with brake
2	RODA.100	Swivel castor Ø100 mm
6	PRUMO.1005	Single Racks Strip 1/2U 2mm
3	2602	Medium duty butt hinge z./p.
3	17343	Overlatch Butterfly Latch Large 14 mm deep
3	1630KEEP	Surface mount keeper plate
2	4903	Rubber foot 20 x 9 mm, black
2	4909	38 mm rubber foot black with steel insert. Height: 20 mm.
2	87991	Telescopic Table Leg Set 73 - 118 cm
1	CHAPA.1000	Identification Plate

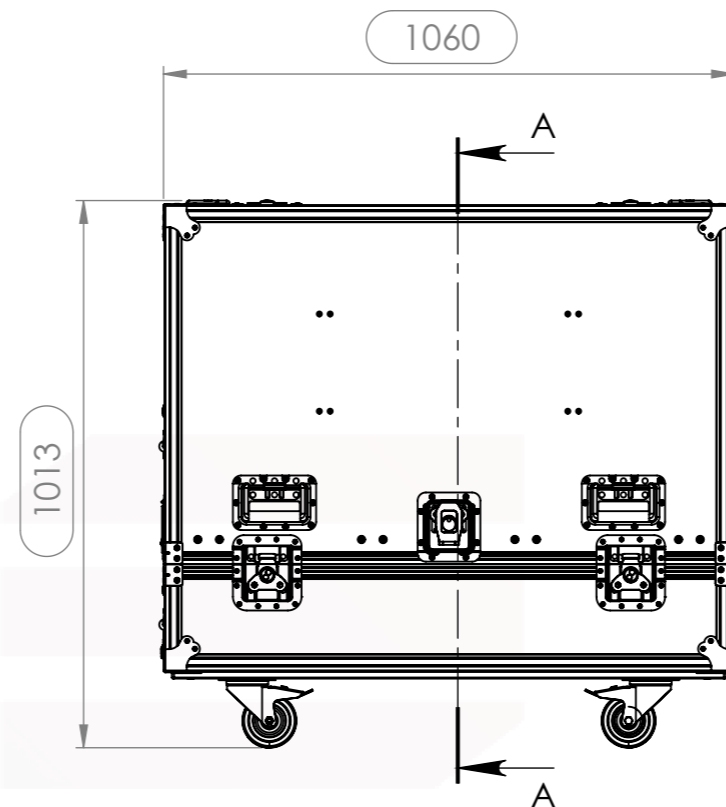
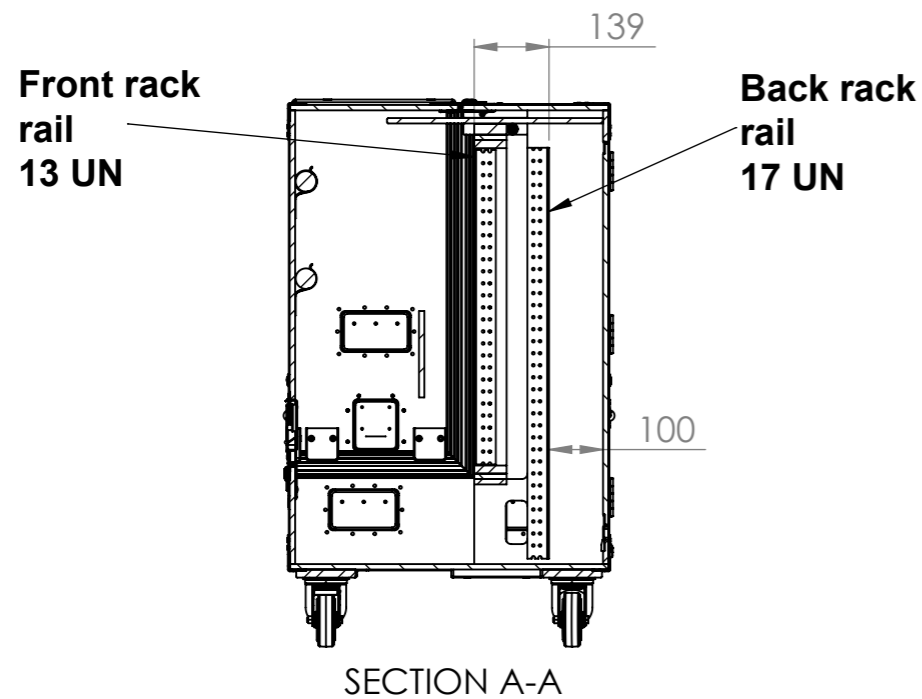
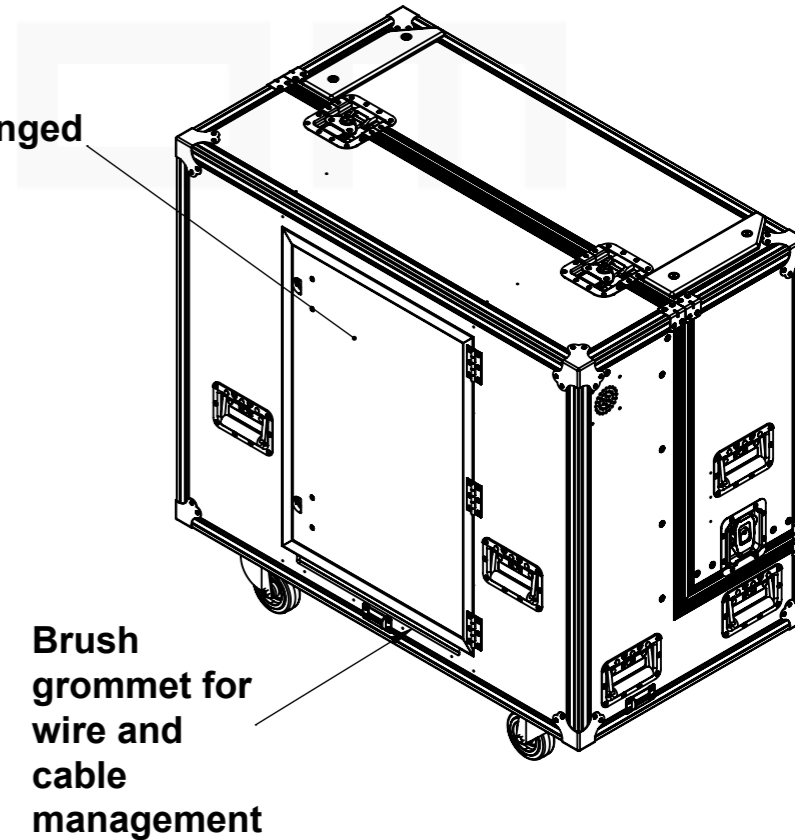
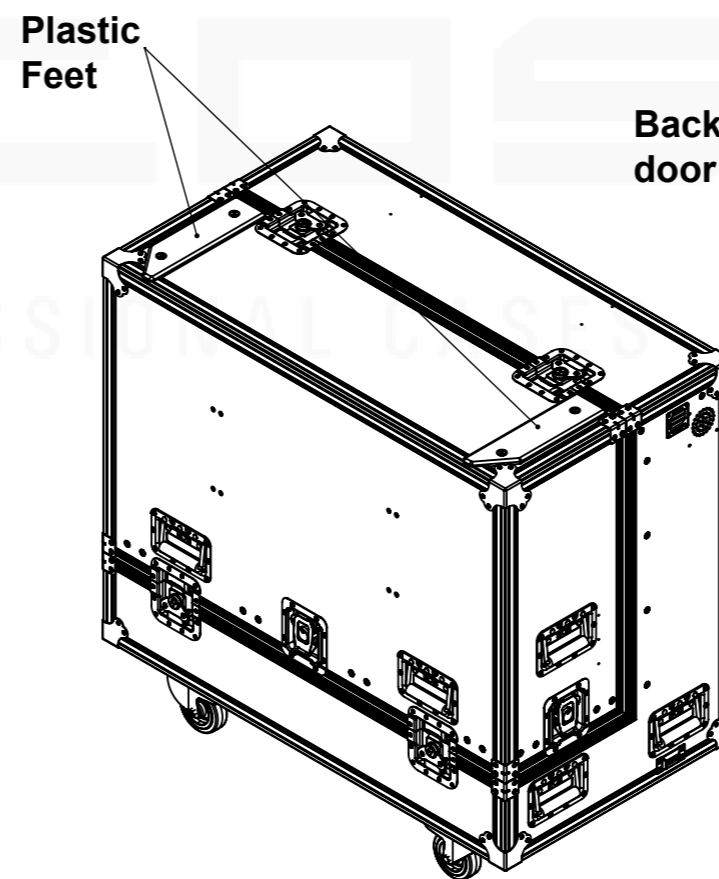

A3

This drawing must not be copied or disclosed without consent of the owner

1st Angle projection

Scale 1:14

units in mm DO NOT SCALE general tolerance 0.8mm

Name	Date
alexandre	04/05/2017
Reference	STAT.112



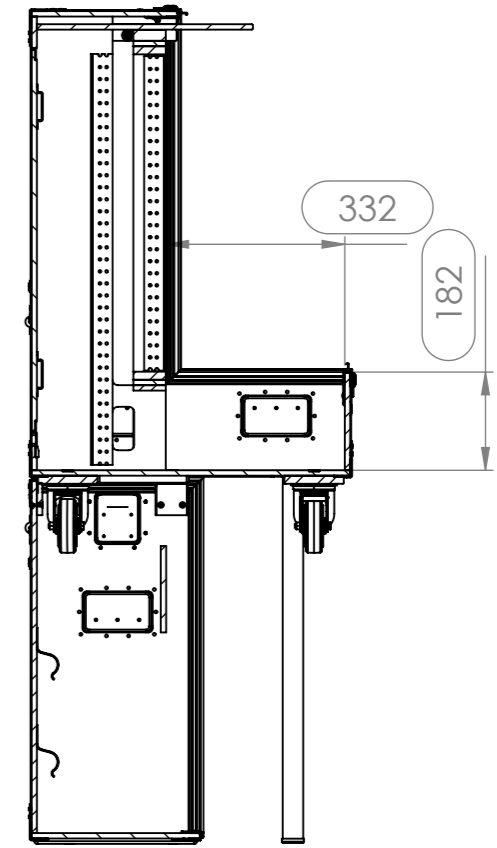
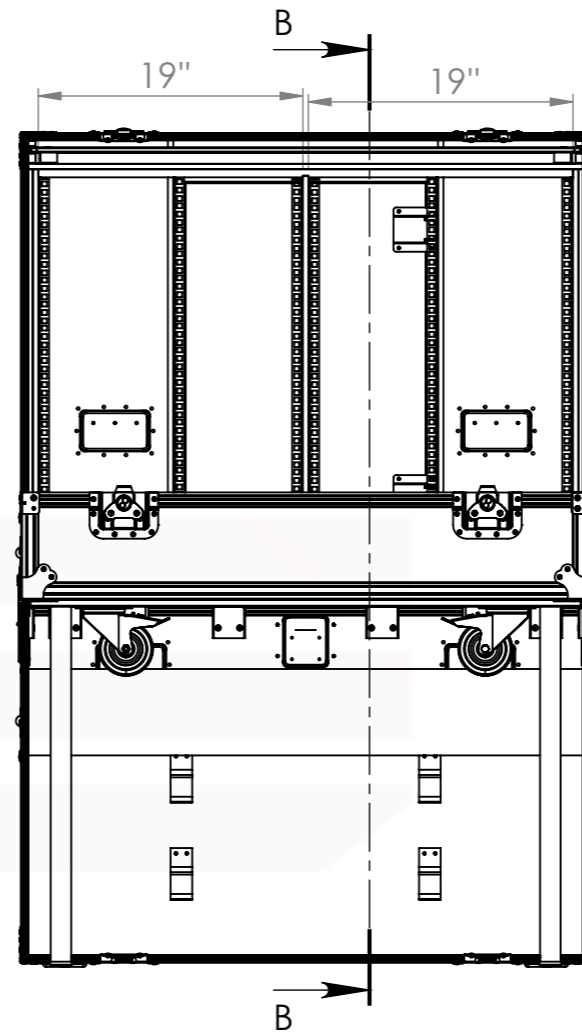
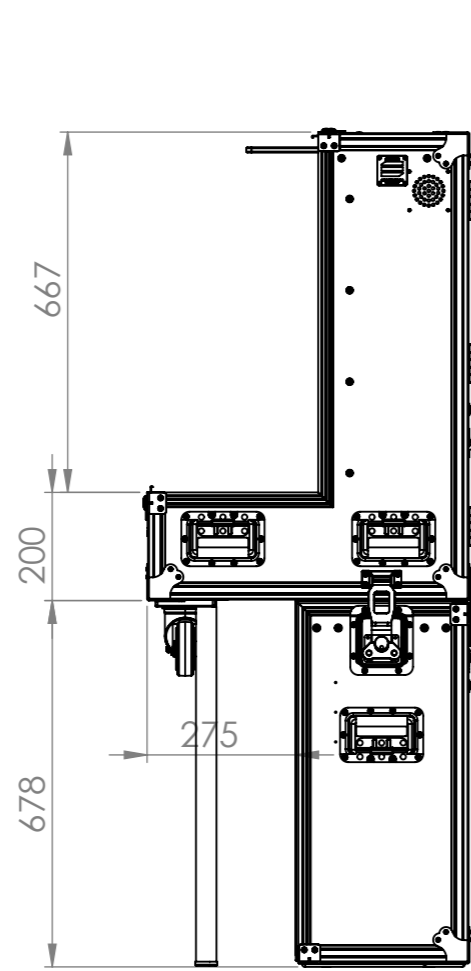

SECTION B-B

HD Foam  
around the  
rack frame

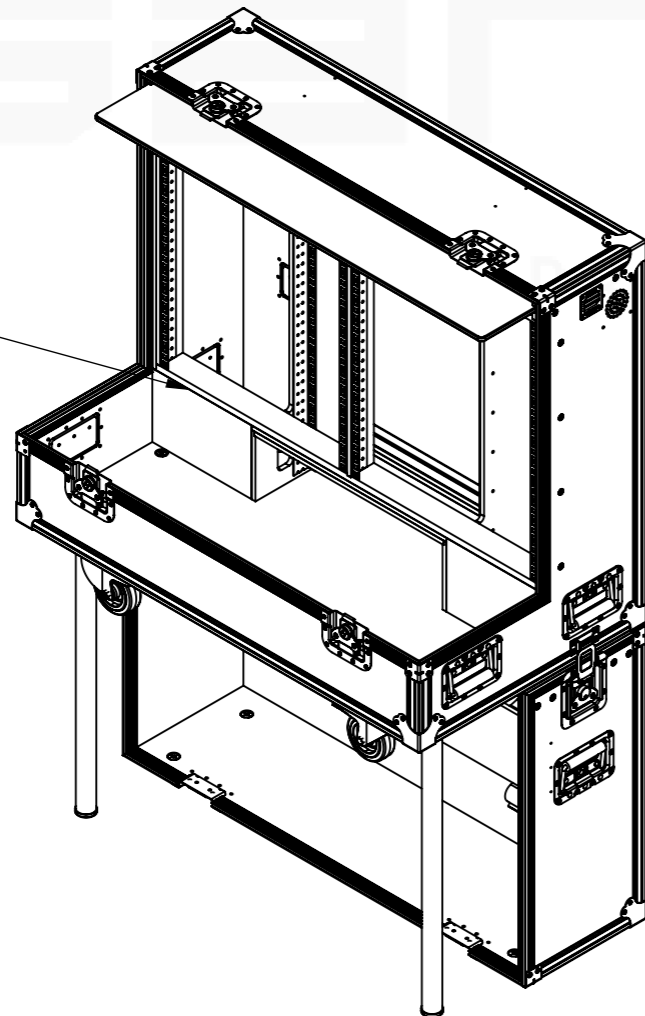

Back rack rail  
17 UN accessible  
from the door

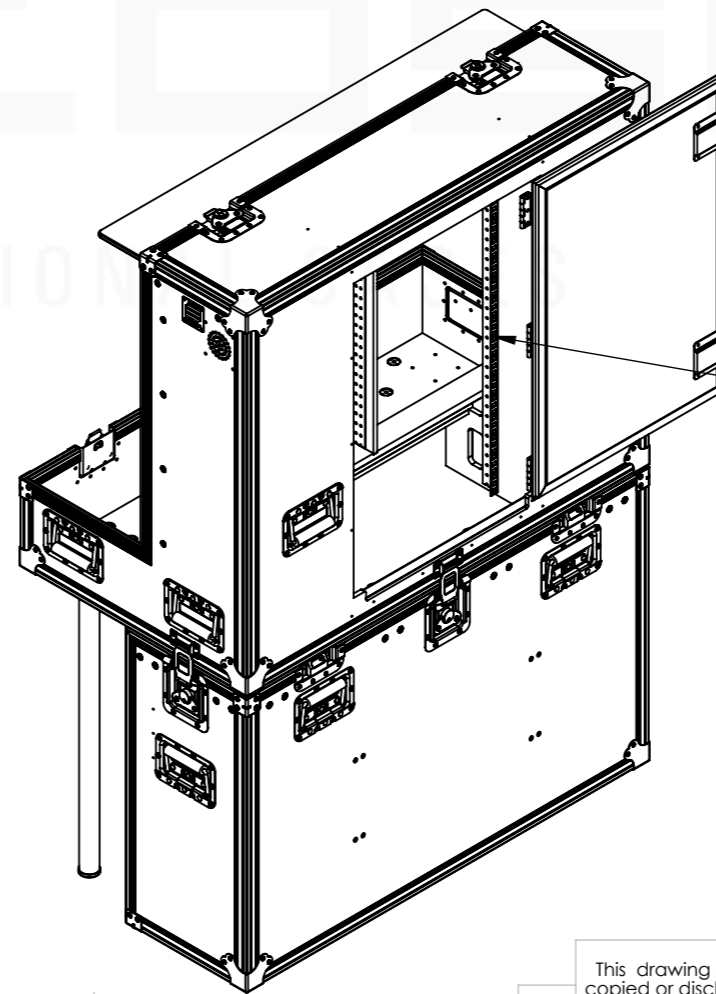

Drawn by	Name	Date
alexandre	alexandre	04/05/2017

Reference	Name	Date
STAT.112	STAT.112	

Scale	units in mm	general tolerance
1:14	DO NOT SCALE	0.8mm

This drawing must not be copied or disclosed without consent of the owner

1st Angle projection



A3