

Equipments	SONY LMD-2110W / SONY MCS-8M / SONY PMWRX50
Weight	Approx. 16 Kg
Wall Thickness	7mm

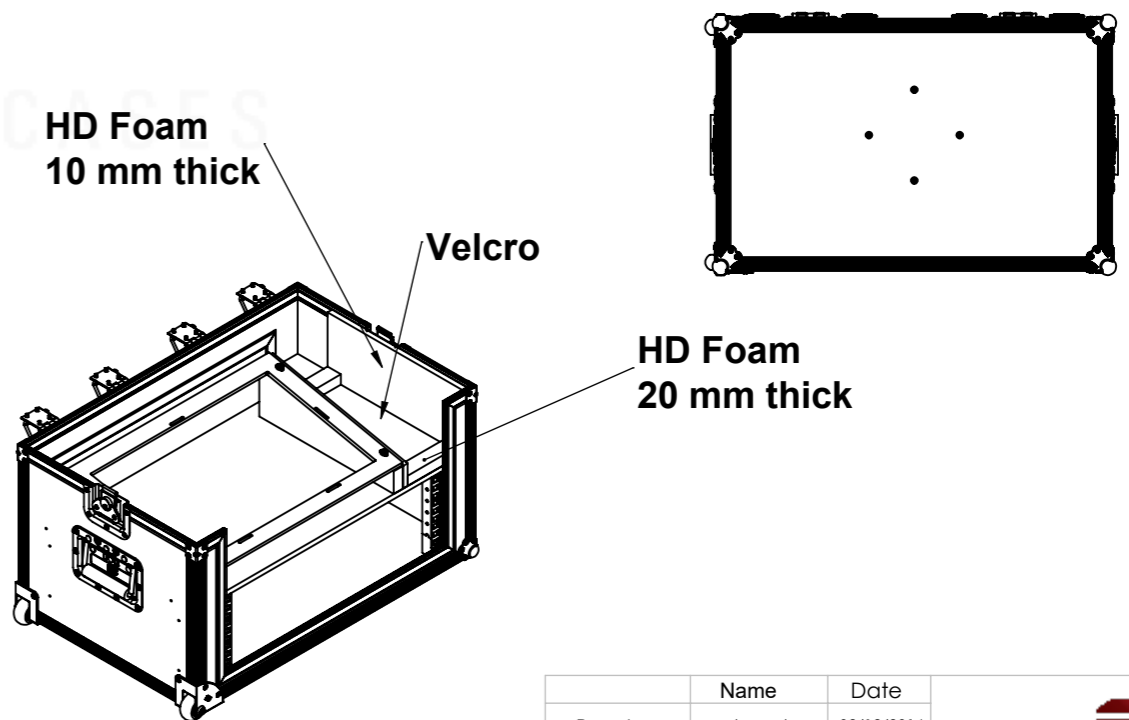

Hardware		
Qty	Ref.	Description
8	40407	Medium corner-brace zinc plated 1,0mm
6	C1345Z	Small ball corner - 3 leg - zinc plated
1	16540	Sliding Latch System - Sliding Latch
1	STAND.003	Stand FC for TFT, VESA 200/100 mm
2	17290S	Key lockable medium Butterfly special
2	37600S	Castor with 48 mm wheel in aluminium
2	4909	38 mm rubber foot black with steel insert. Height: 20 mm.
2	34082	Recessed sprung handle medium model
2	2252	Heavy duty hook over hinge.
4	2524	Heavy Duty Strut Hinge
4	PRUMO.1005	Single Racks Strip 1/2U 2mm

Name	alexandre	Date	02/12/2016
Reference	STAT.105		
Scale	1:12	units in mm	general tolerance 0.8mm
1st Angle projection	FC REGI VIDEO, 2U + MIXER + ECRA		

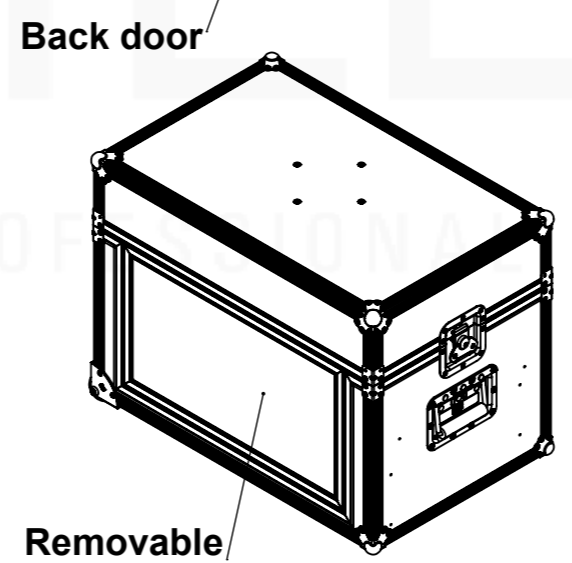
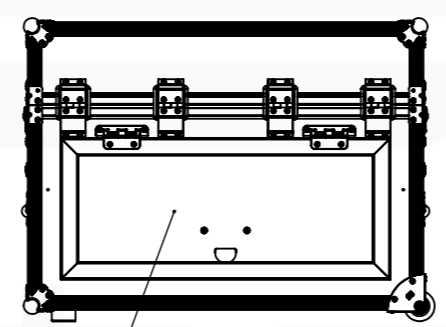
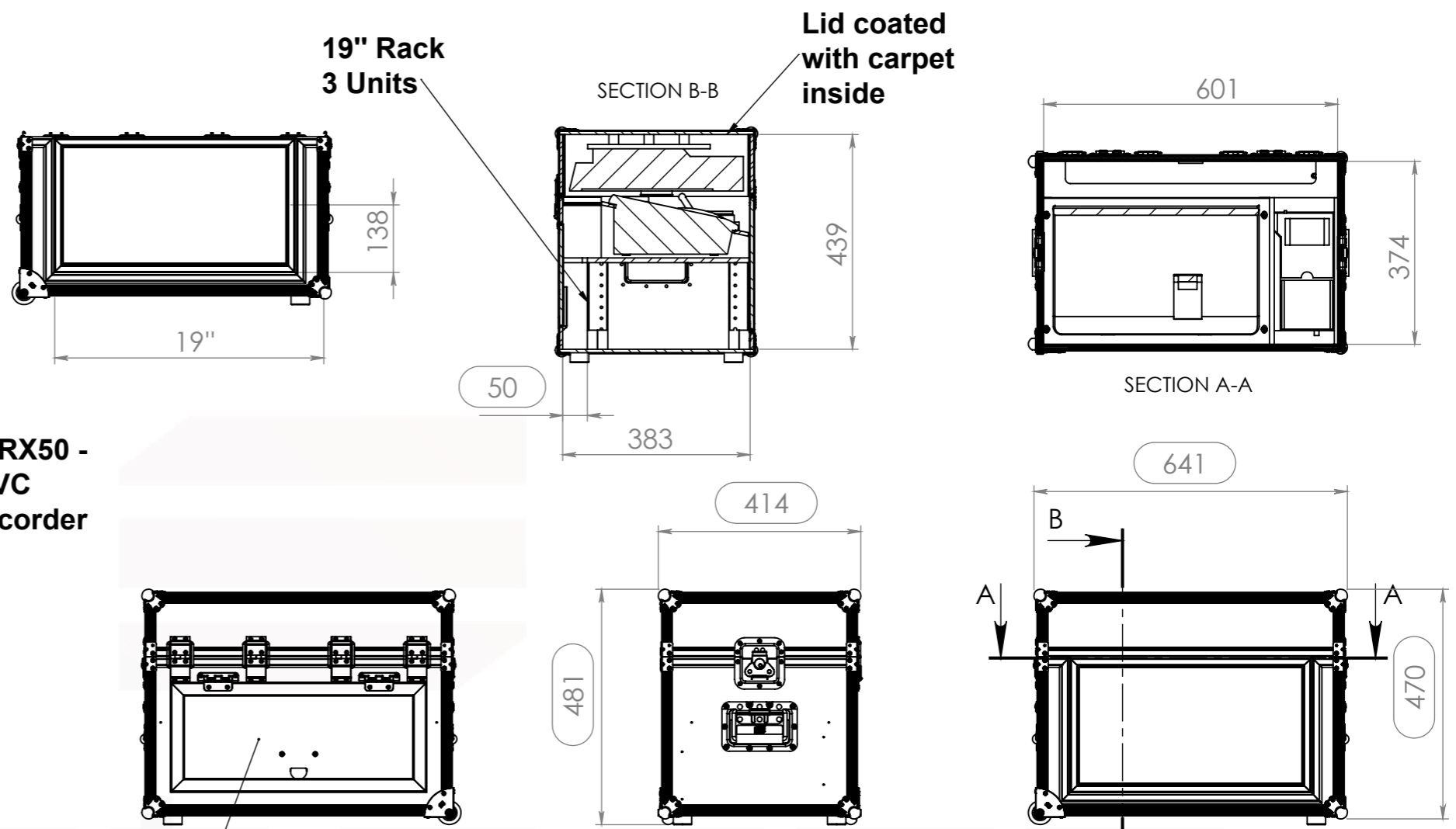
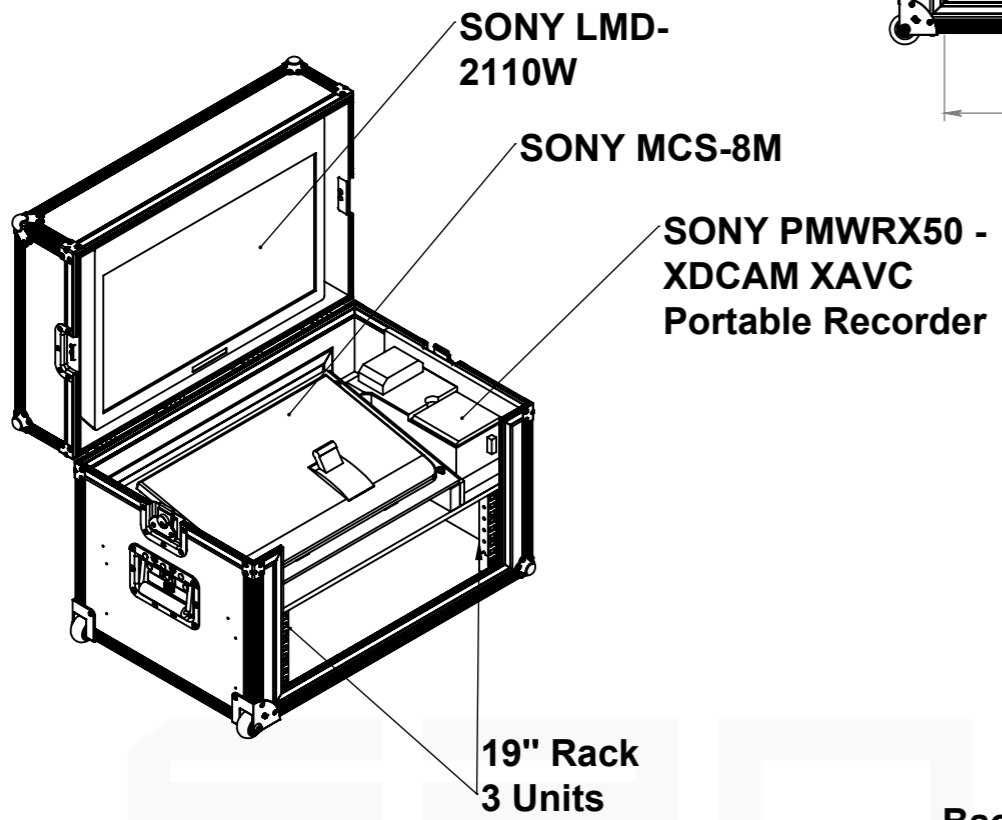

This drawing must not be copied or disclosed without consent of the owner

A3