

Equipment		D&B XSL8/ XSL12	
Width	Depth	Height	
700	504	284	
Weight	Approx. 39 Kg		
Internal Dimensions			
Width	Depth	Height	
704	506	1139	
Weight	Approx. 55.01 Kg		

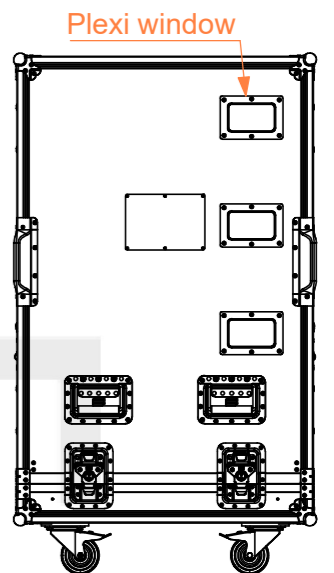

For transportation, place in the socket with a 0° angle.

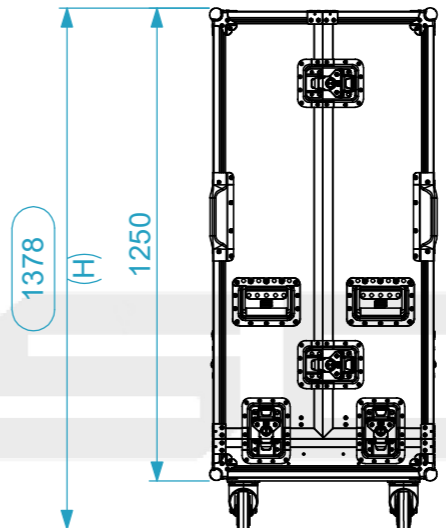
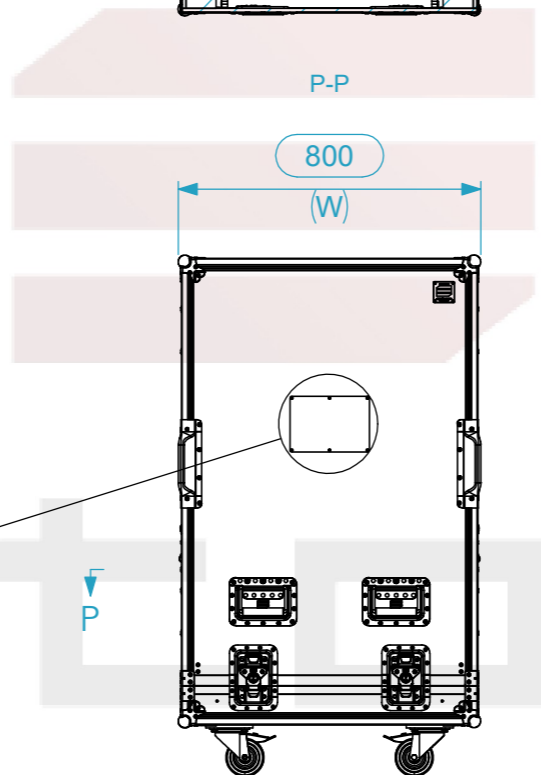
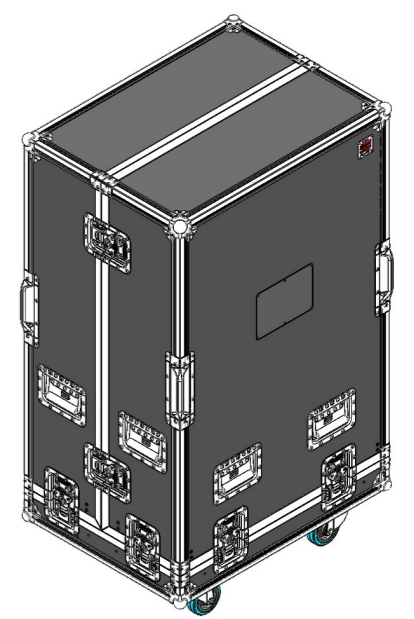
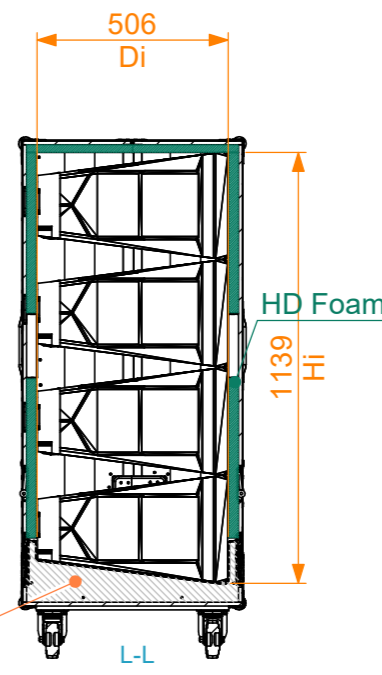
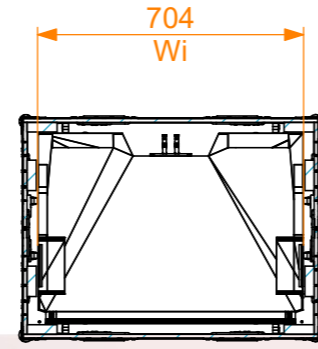
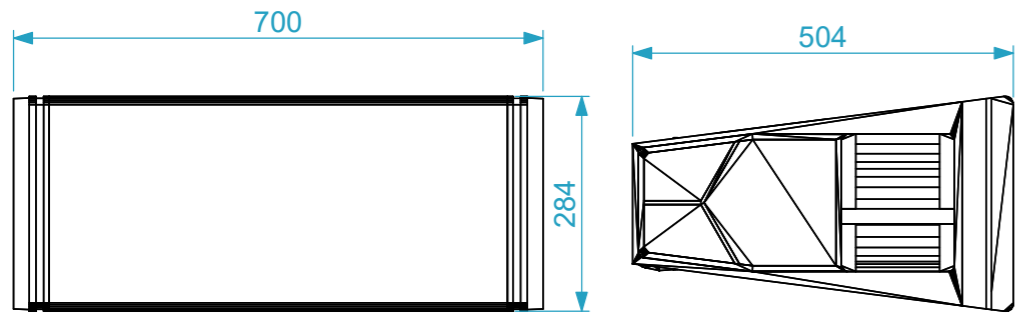
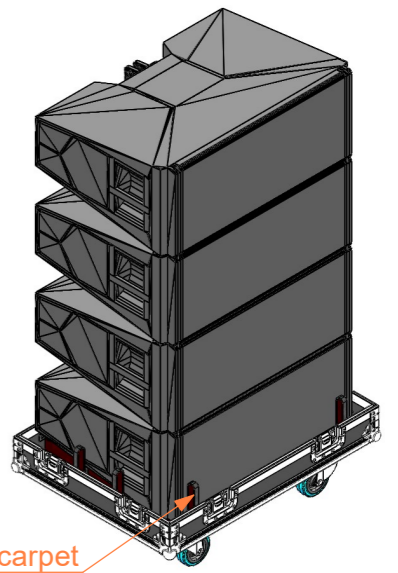
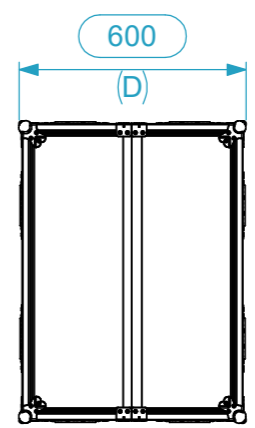
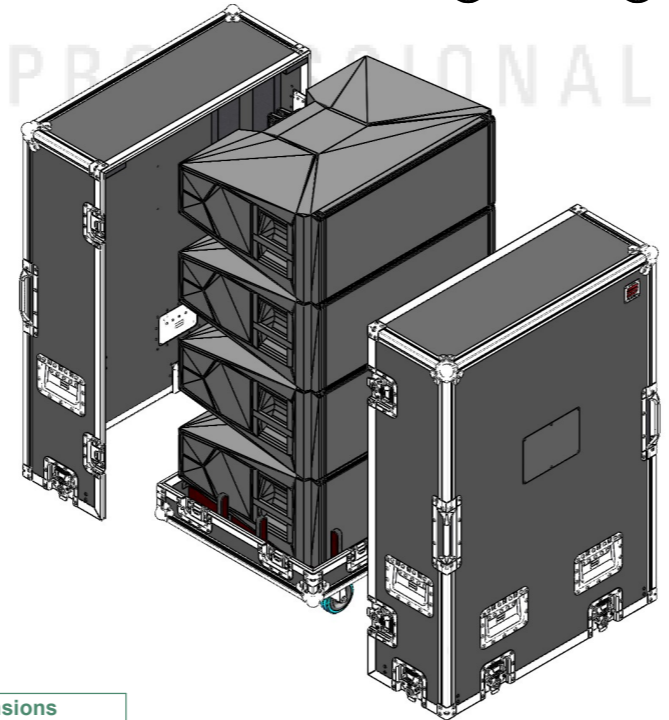
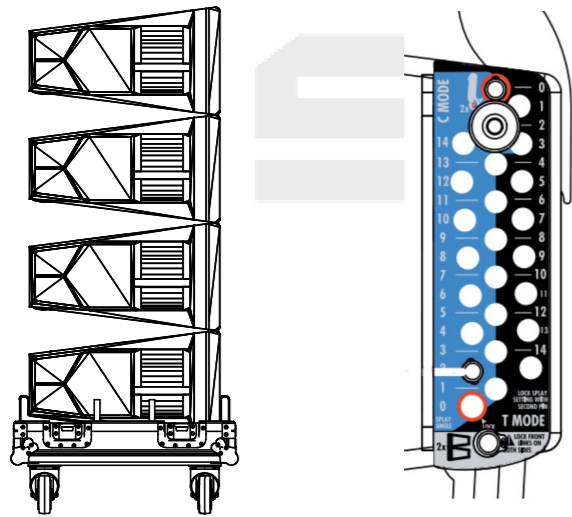

General External Dimensions		Usable Inner Dimensions		Wood Inner Dimensions	
W	Width	Wi	Inside Width	WWi	Wood Inside Width
D	Depth	Di	Inside Depth	WDi	Wood Inside Depth
H	Height	Hi	Inside Height	WHi	Wood Inside Height

Name	Date
Drawn by jose.couto	13/05/2023
Reference	SP3.DBA.XSL.04
Scale	1:20
units in mm	general tolerance 0.8mm
DO NOT SCALE	
Flight case PRO-3, 4x D&B XSL8 / XSL12 (w/ plexi window)	



This drawing must not be copied or disclosed without consent of the owner



A3