

Max. dimensions equipment

Length	Width	Height
570	580	123

REVISIONS

ZONE	REV.	DESCRIPTION	DATE	APPROVED
-	0	Final Drawing	02/10/2015	Carlos Rodrigues

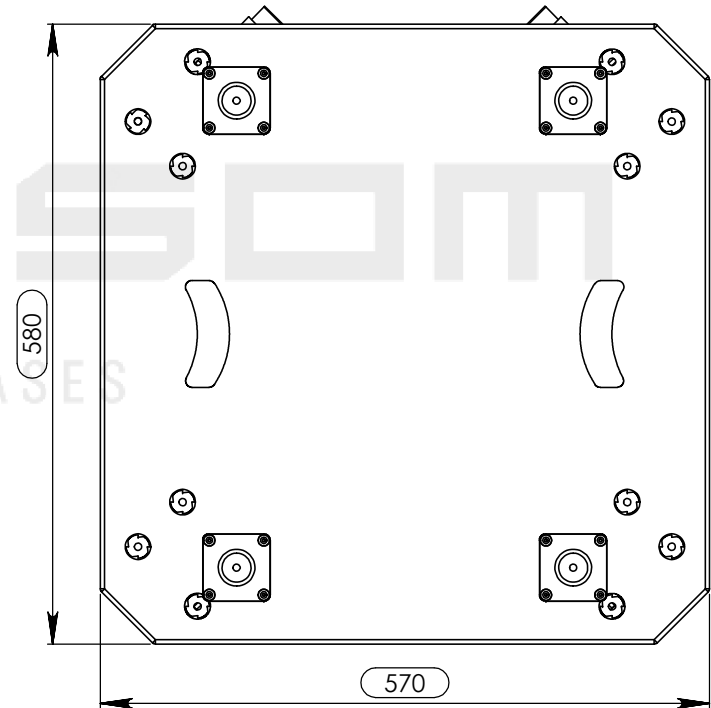
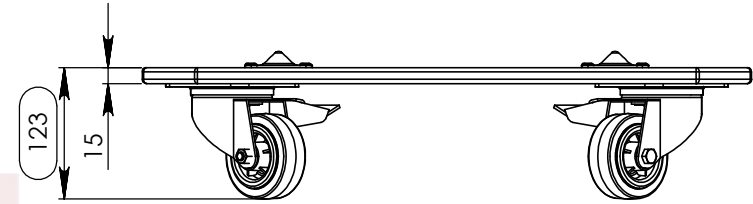
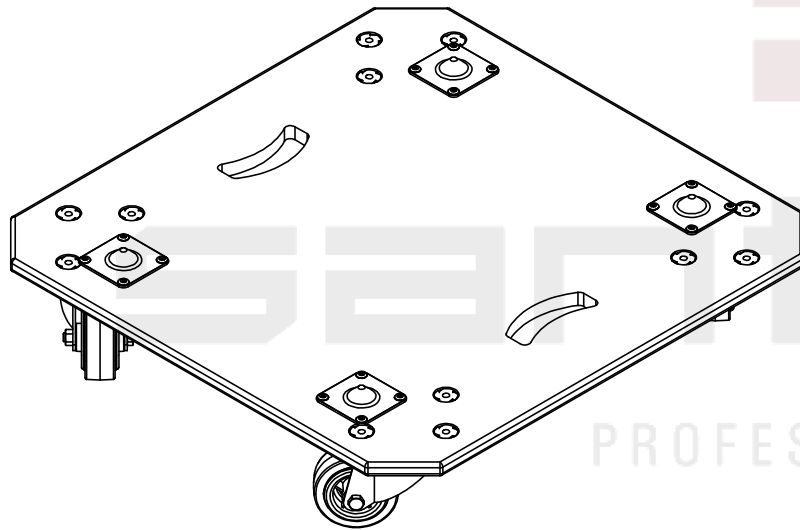

Hardware

Qty	Ref.	Description
2	RODA.80	Swivel castor Ø80 mm without brake
2	RODA.80T	Swivel castor Ø80 mm with brake
4	4937	

This drawing must not be copied or disclosed without consent of the owner



Scale
1:5

UNITS IN
mm
DO NOT SCALE

general tolerance
0.8mm

Name	Date
projects	02/10/2015

Reference SKTAS2T.41

SKATE, AS27
SLIDING-RACK 19" 410MM.

