

Interior dimensions		
Width	Depth	Height
689	307	380
Weight	Approx. 8 Kg	
Wall Thickness		7mm

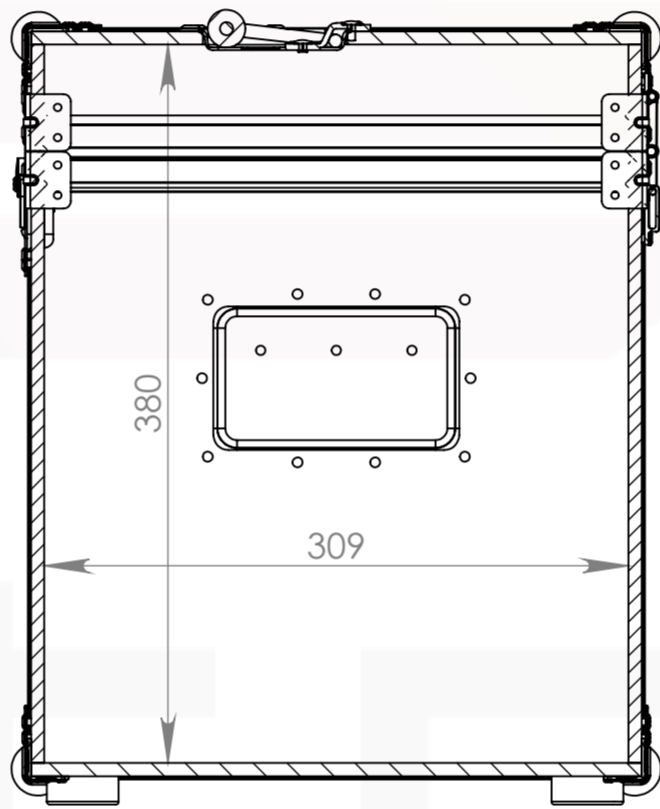

SECTION P-P

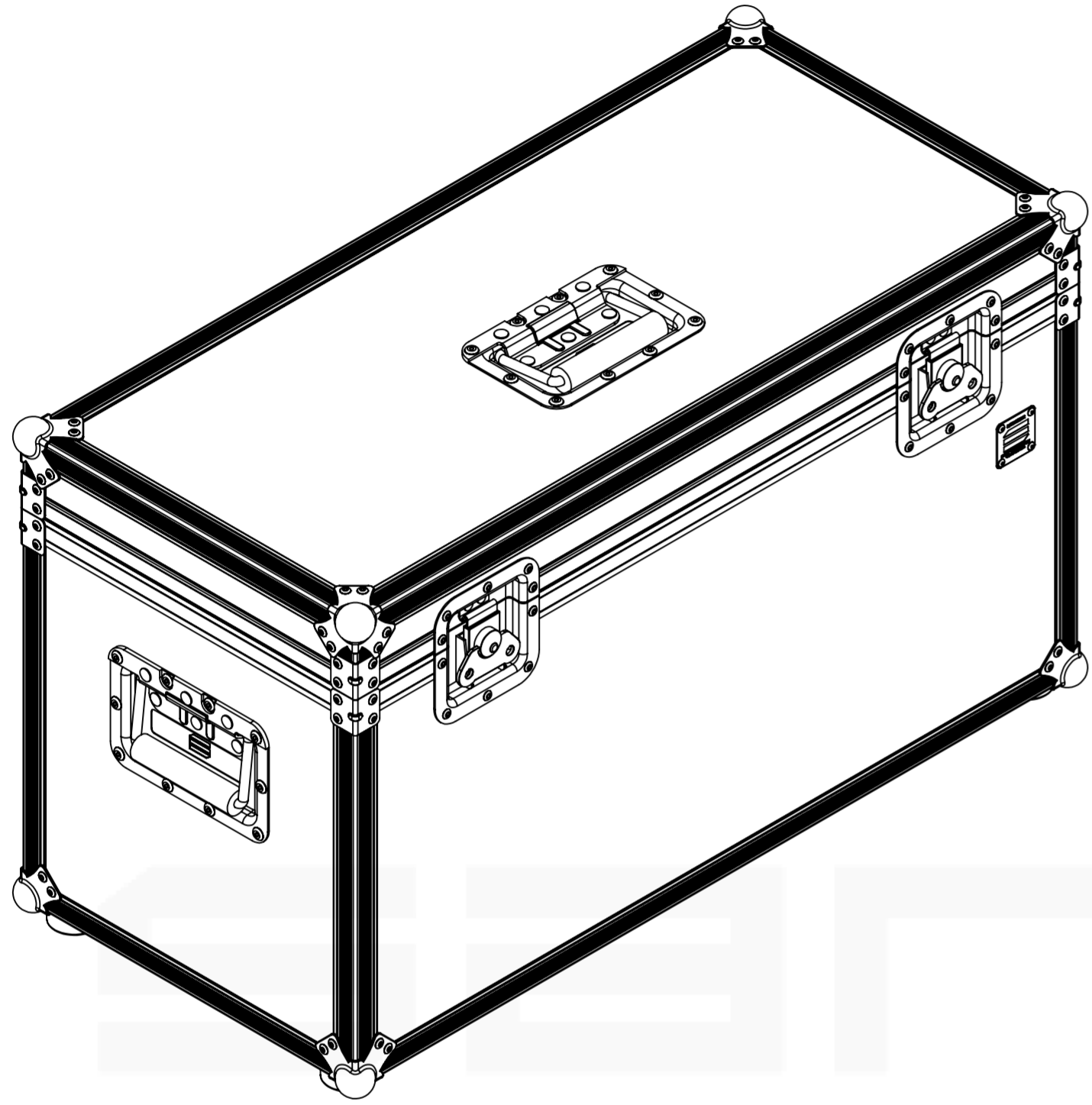
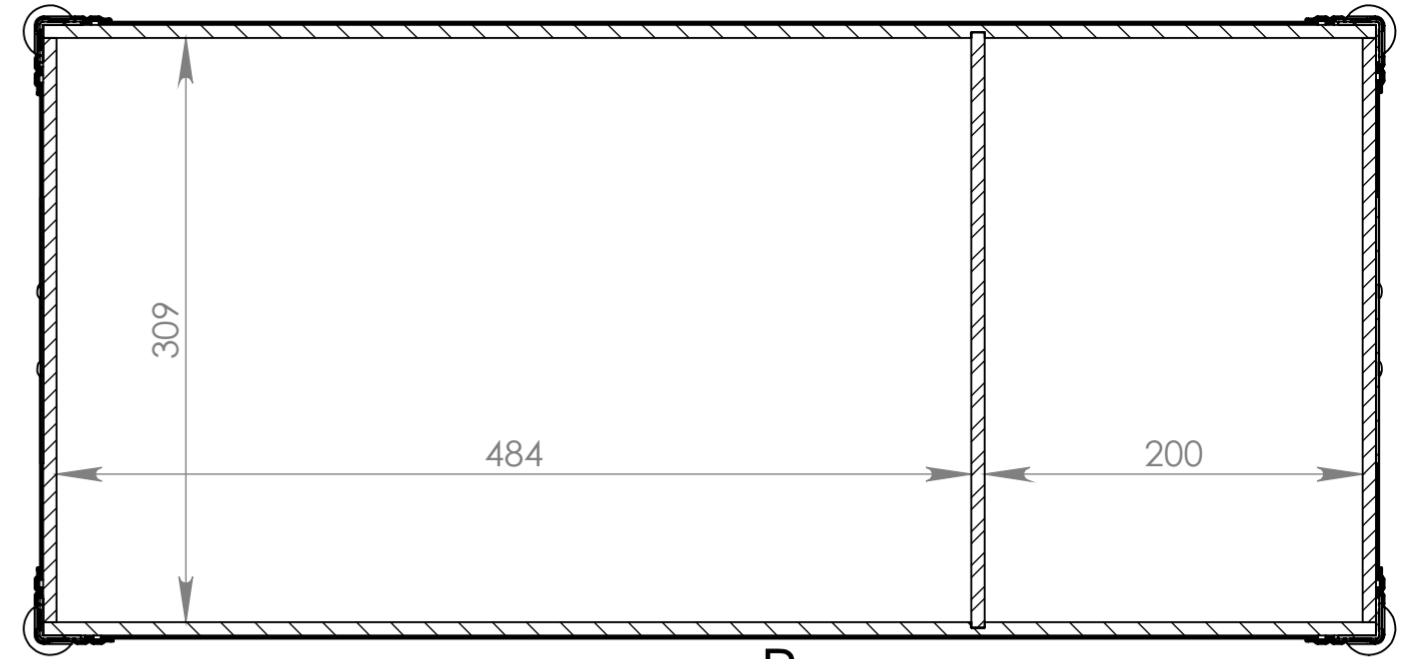

SECTION O-O

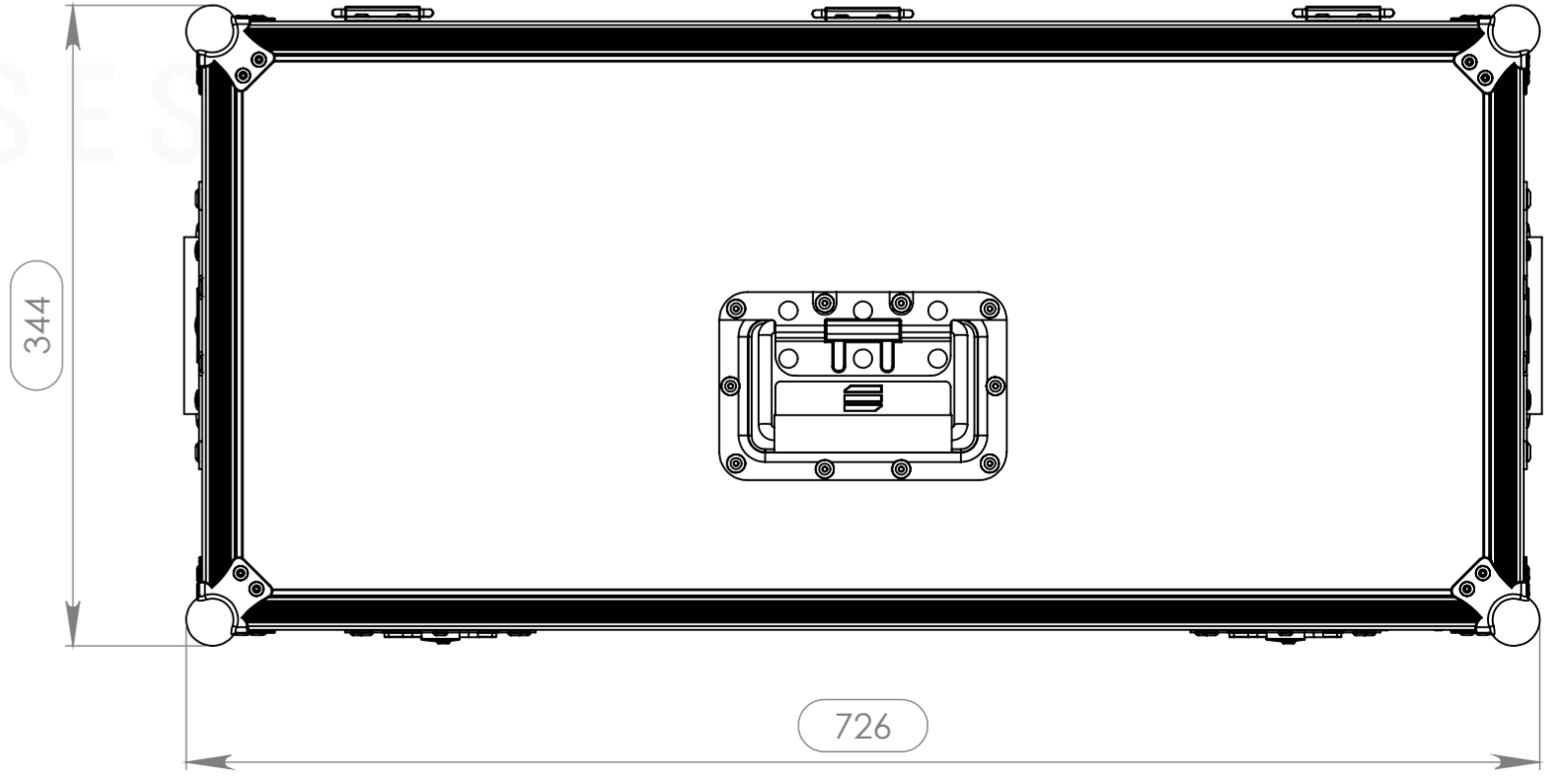
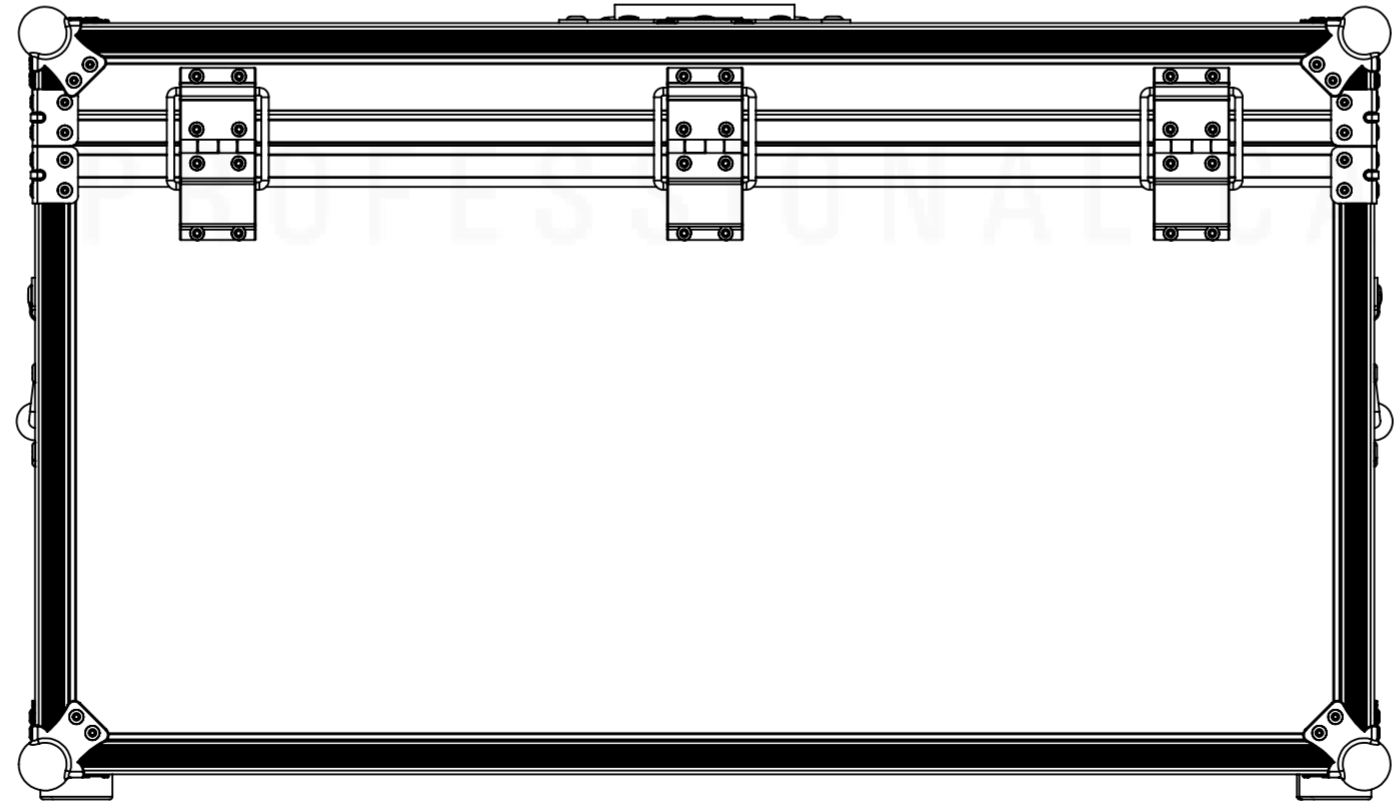
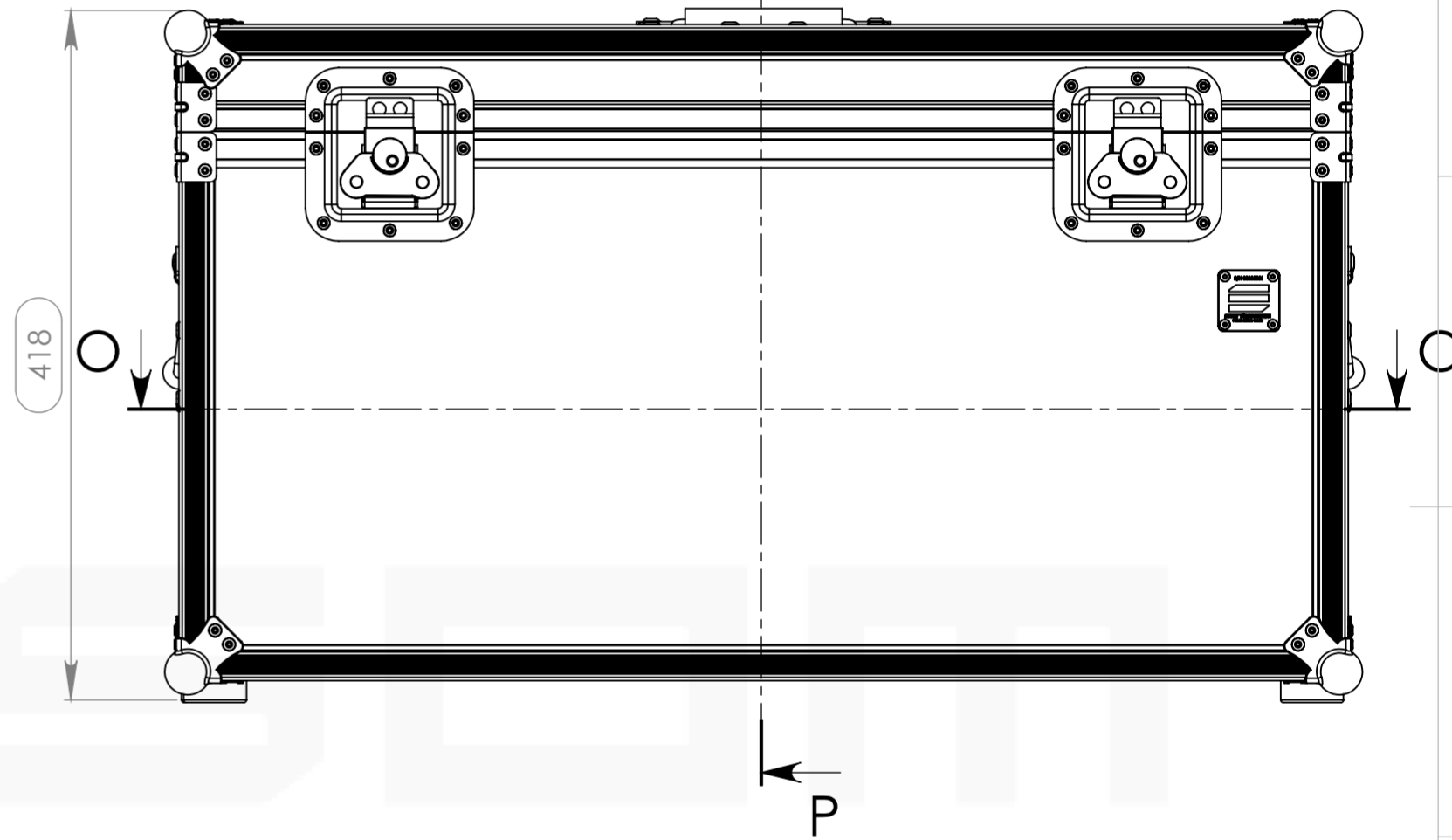

Hardware		
Qty	Ref.	Description
8	40407	Medium corner-brace zinc plated 1,0mm
8	4112	Small ball corner - 3 leg - zinc plated
2	17290S	Key lockable medium Butterfly special
3	2524	Heavy Duty Strut Hinge
4	4907	Rubber foot 38mm x 15 mm
3	34082	Recessed sprung handle medium model
1	CHAPA.1001	Identification Plate

Drawn by	joao	Name	SCPS.0720	Date	13/10/2016
Reference	SCPS.0720	Scale	1:4	Units in mm	DO NOT SCALE
This drawing must not be copied or disclosed without consent of the owner		1st Angle projection	FLIGHTCASE, 720X340X410MM	general tolerance	0.8mm

