

Internal Dimensions		
Width	Depth	Height
513	403	146
Weight	Approx. 4 Kg	
Wall Thickness		7mm

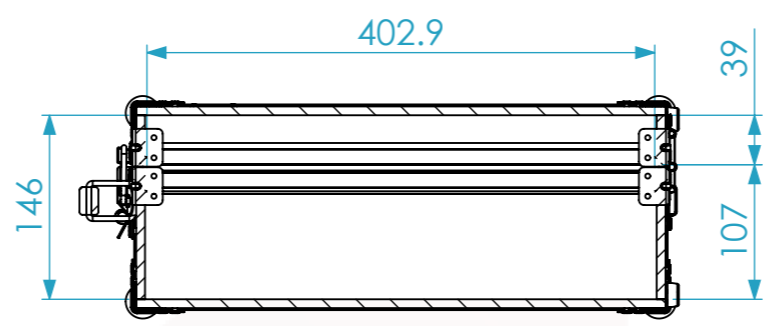

SECTION A-A

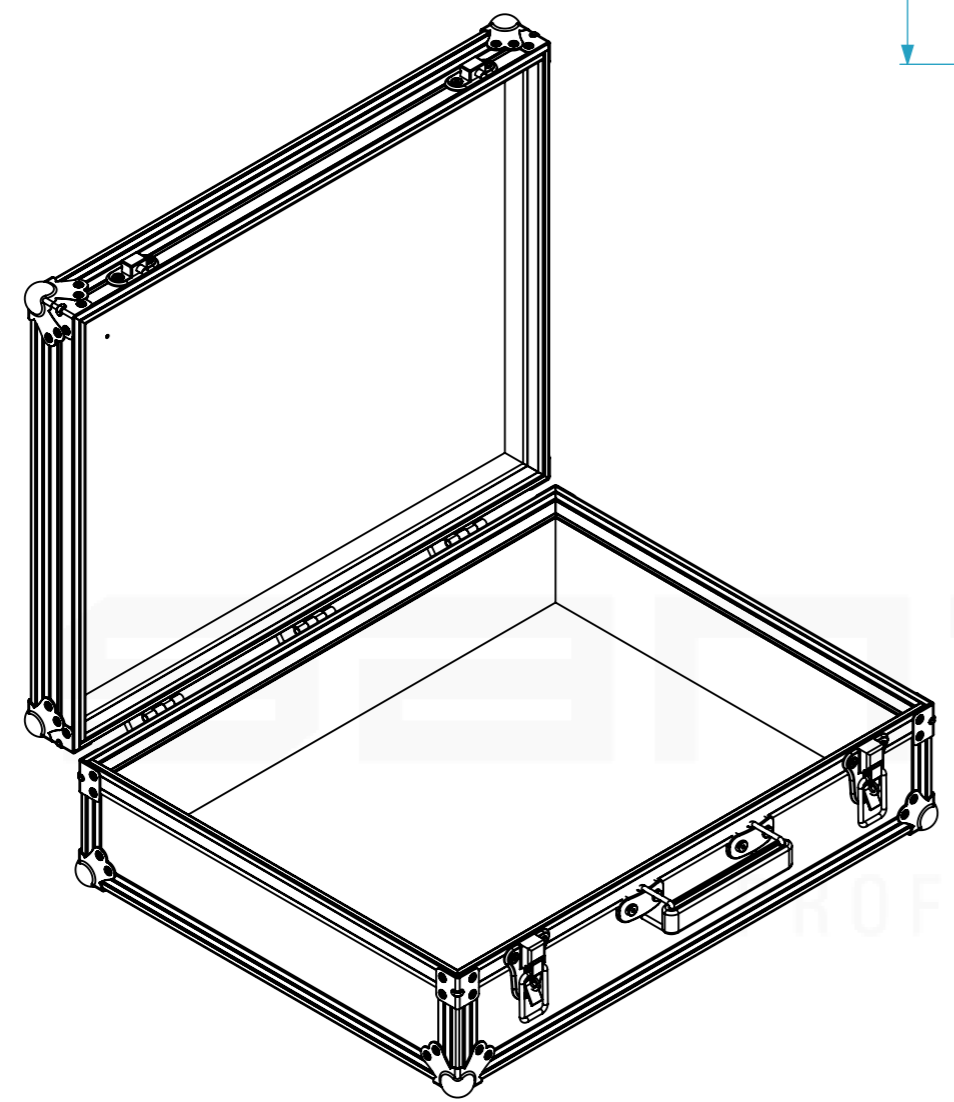
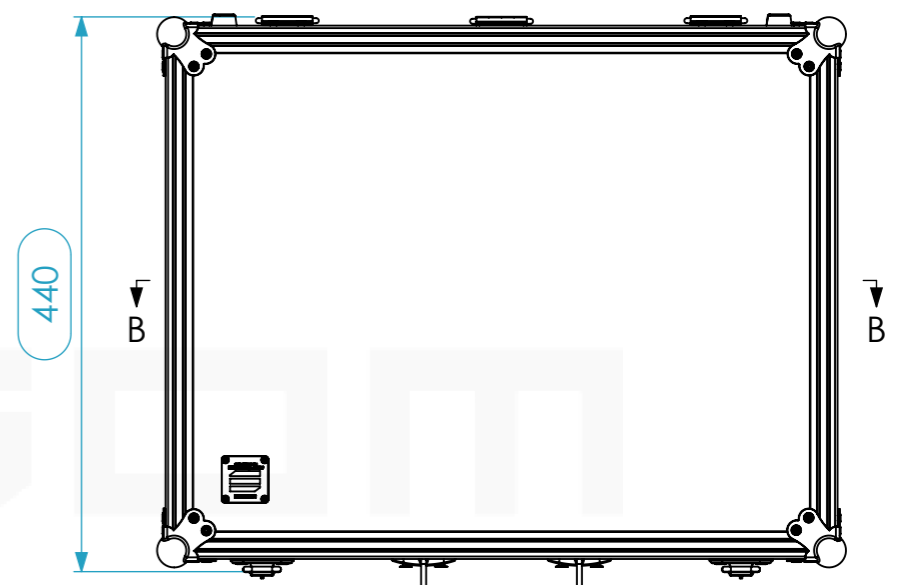
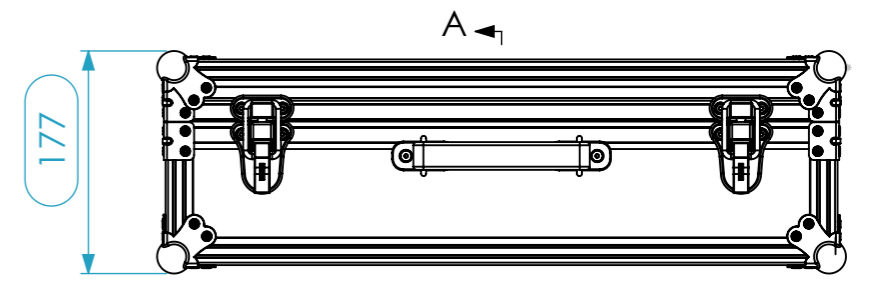

SECTION B-B

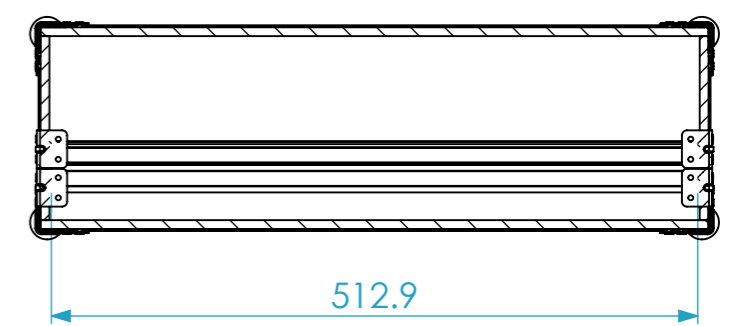

Hardware		
Qty	Ref.	Description
1	CHAPA.1001	Identification Plate
4	4903	Rubber foot 20 x 9 mm, black
4	40407	Medium corner-brace zinc plated 1,0mm
2	16021	Large padlocking drawbolt
3	2524	HEAVY DUTY STRUT HINGE WITH BLACK PLATE
4	40407	
8	C1345Z	Small ball corner - 3 leg - zinc plated
1	3415	Leather Case Handle

This drawing must not be copied or disclosed without consent of the owner

Drawn by	Name	Date
CatarinaDuque	CatarinaDuque	12-01-2018
Reference	S1AA.0554418	
Scale	units in mm	general tolerance
1:6	DO NOT SCALE	0.8mm
1st Angle projection	FC S1AA. S13X403X146	

