

Dimensões

Comprimento	Largura	Altura
709	25	780
Peso	Approx. 4.52 Kg	
Espessura		10mm

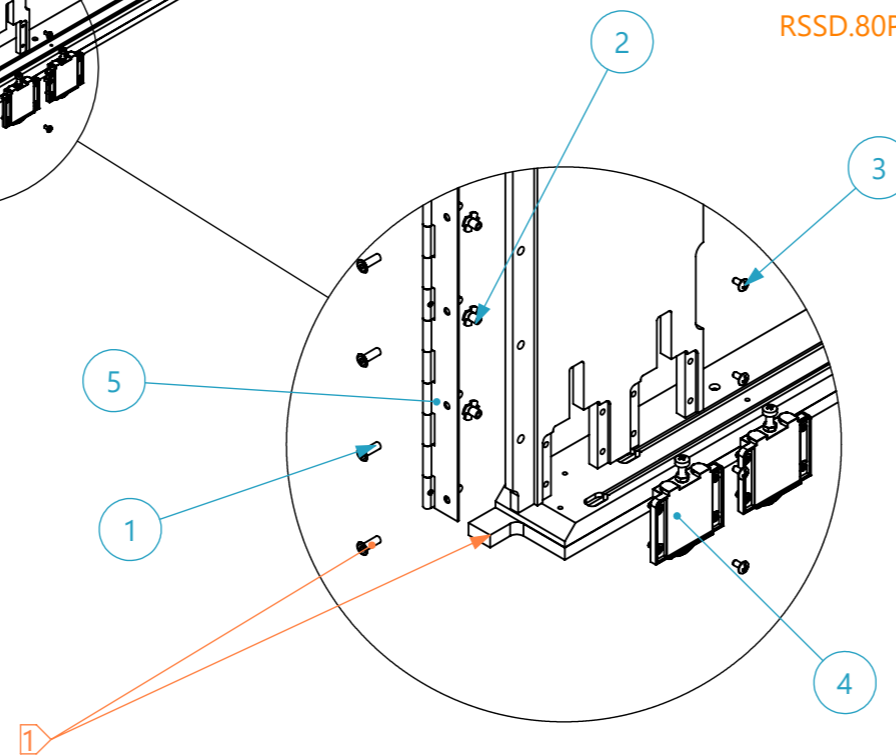
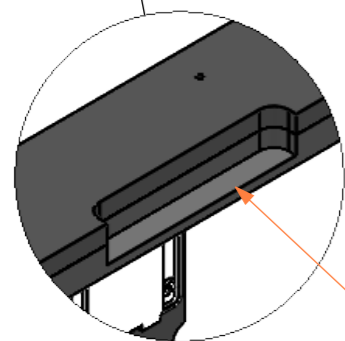
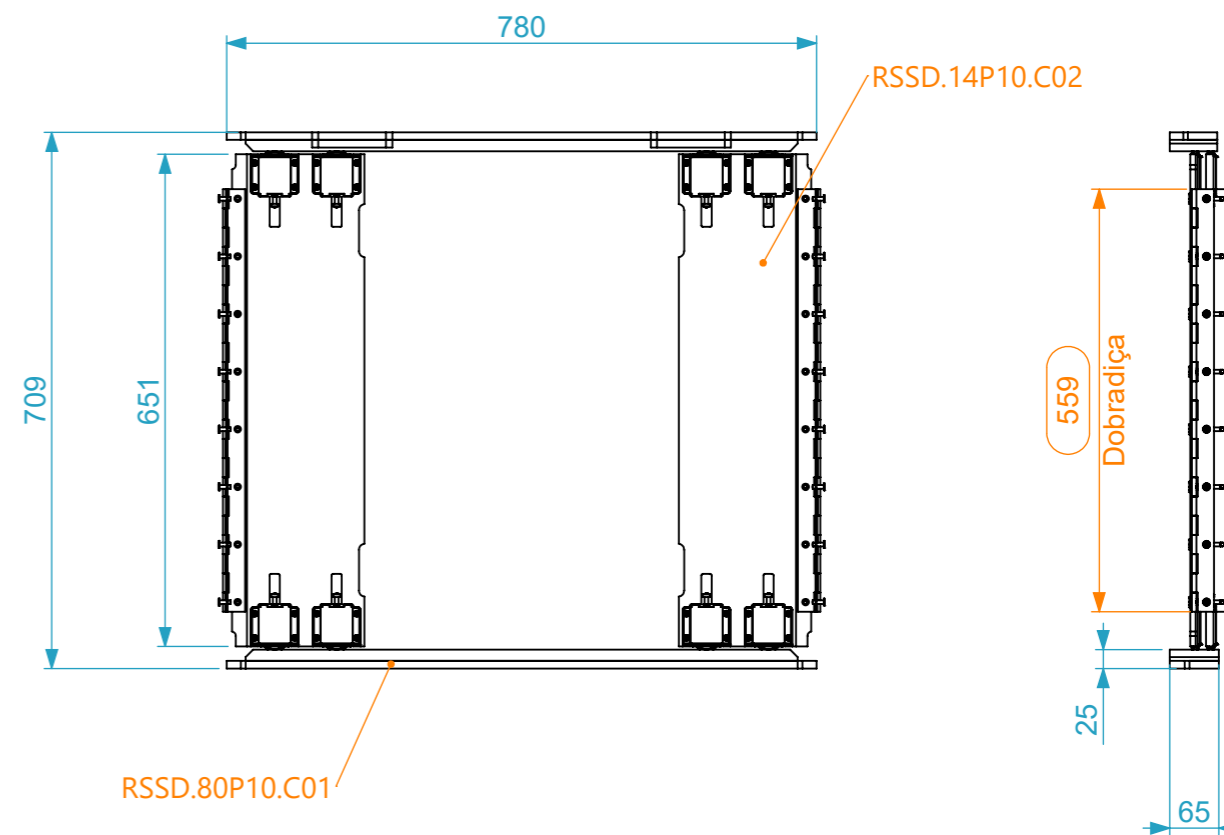
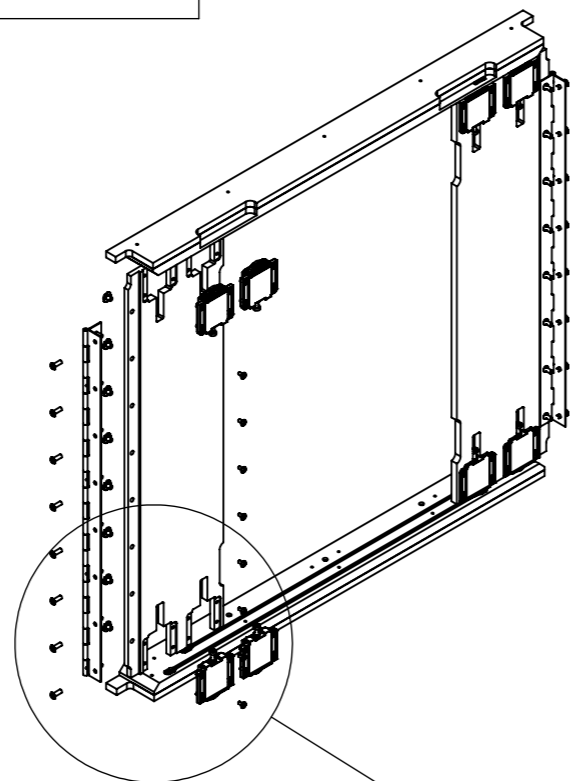
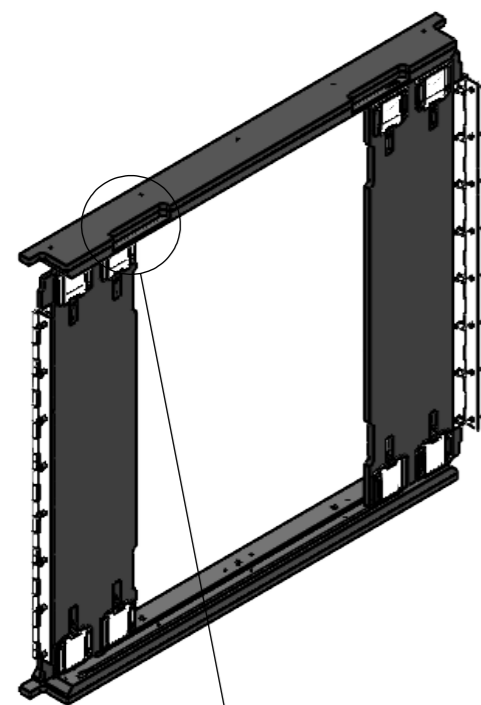

NOTAS:

- 1) GUIAS E REBITES DAS PORTAS CLASSIFICADOS COMO SUB-COMPONENTE => SEPARADOS NA OP DA RACK
2. APLICAR AS PORCAS DE GARRA, FIXAR AS DOBRADIÇAS E OS CARROS (CARDES.1001) NA PRÉ-MONTAGEM
- 3) GUIAS COM REBAIXOS SÃO MONTADAS EM CIMA (PARA COMPENSAR OS ENCAIXES DE RODAS)

Lista de Componentes (x2)

Item nº	Quant.	Descrição	Ref.
1	16	Rebite Multigrip AL 4,8x15 oxidado/preto	RIVET.4815MG.90
2	16	PORCA C/GARRA M4	DIN6919.M4.ZC
3	16	PARAFUSO COMBI CABEÇA OVAL M4x8 - Zincado	DIN0082.M408.ZC
4	8	Carro p/ sistema deslizante	CARDES.1001
5	2	Dobradiça de plano 1830x51mm - zincado	2606

Lista de Componentes

Item nº	Quant.	Descrição	Ref.
1	1	Guias Portas p/ Double Sliding Rack RSS - 800 Prof.	RSSD.80P10.C01
2	1	Réguas Desliz. Portas 14U p/ Double Sliding Rack RSS	RSSD.14P10.C02

Material	Name	Date	 santosom PROFISSIONAL CARDS
Drawn by	CarlaSilva	07/06/2025	
Reference	RSSD.1480.P10		
This drawing must not be copied or disclosed without consent of the owner		Scale 1:10	units in mm DO NOT SCALE general tolerance 0.8mm
1st Angle projection		Sistema Portas Deslizantes 14U p/ Double Sliding Rack RSS	