

Dimensões		
Comprimento	Largura	Altura
1200	480	615
Peso	Approx. 40 Kg	
Espessura		10mm

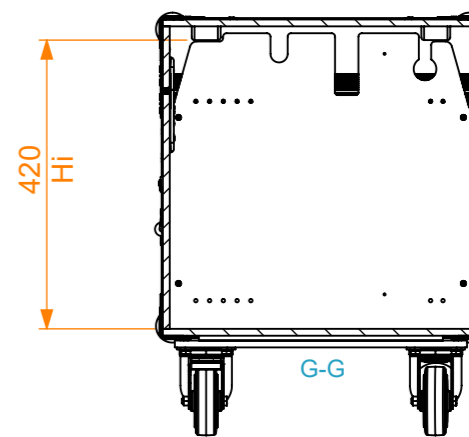

Lista de Componentes			
Item nº	Quant.	Descrição	Ref.
1	1	Malão PRO, X1 120.48.48 (116x43x44 WID)	X1AAR.1204848

This drawing must not be copied or disclosed without consent of the owner	Drawn by	alexandre	Date	26/04/2022
	Reference	RLF02.1204848A		
	Scale	1:11	units in mm	general tolerance
1st Angle projection	FC Mod, 2 Motores		DO NOT SCALE	0.8mm
		436x300x420mm - Modelo 2		

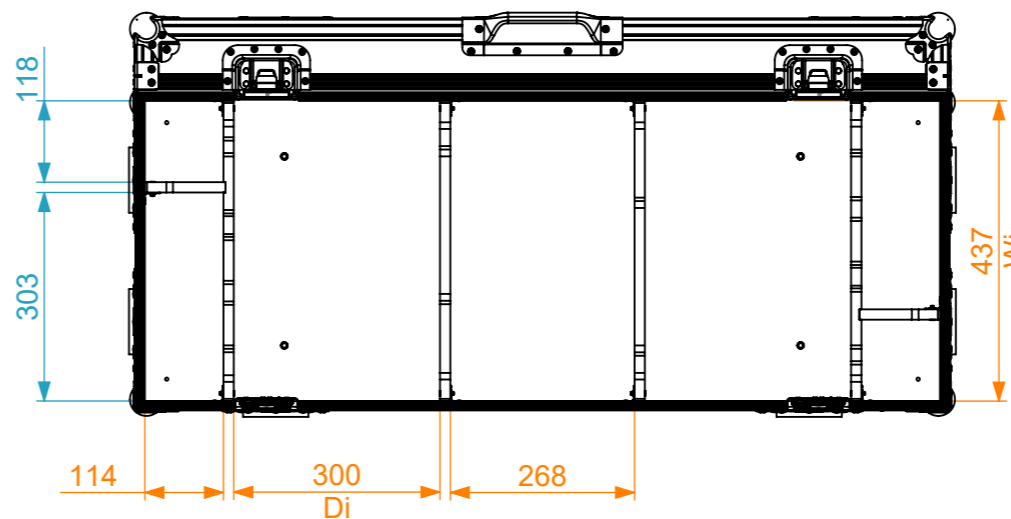
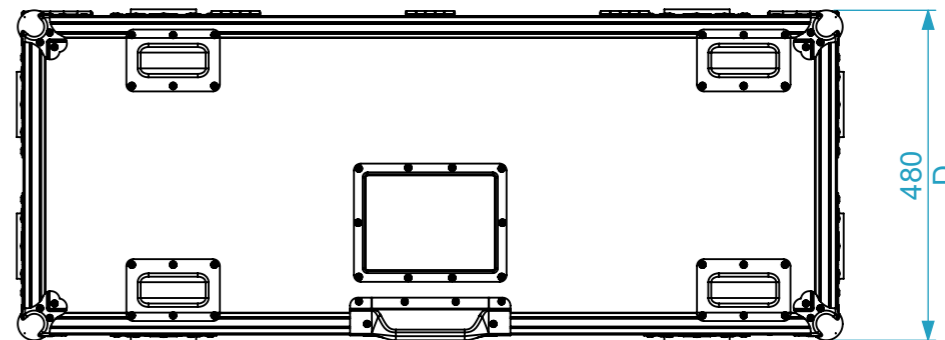
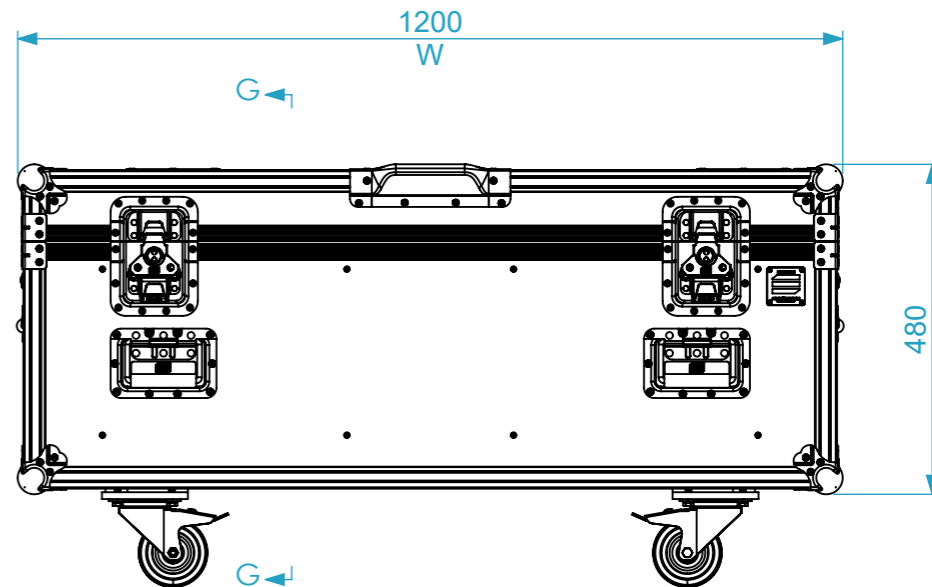
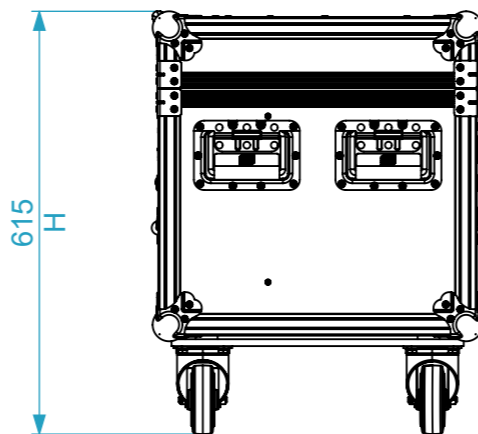
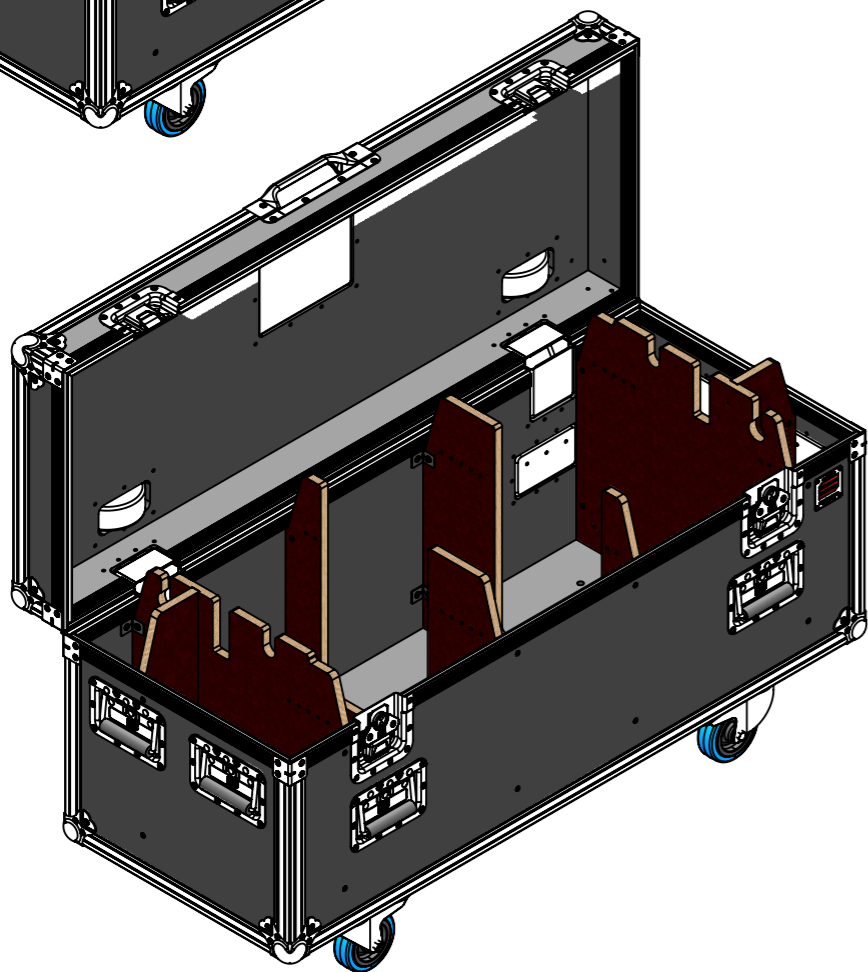
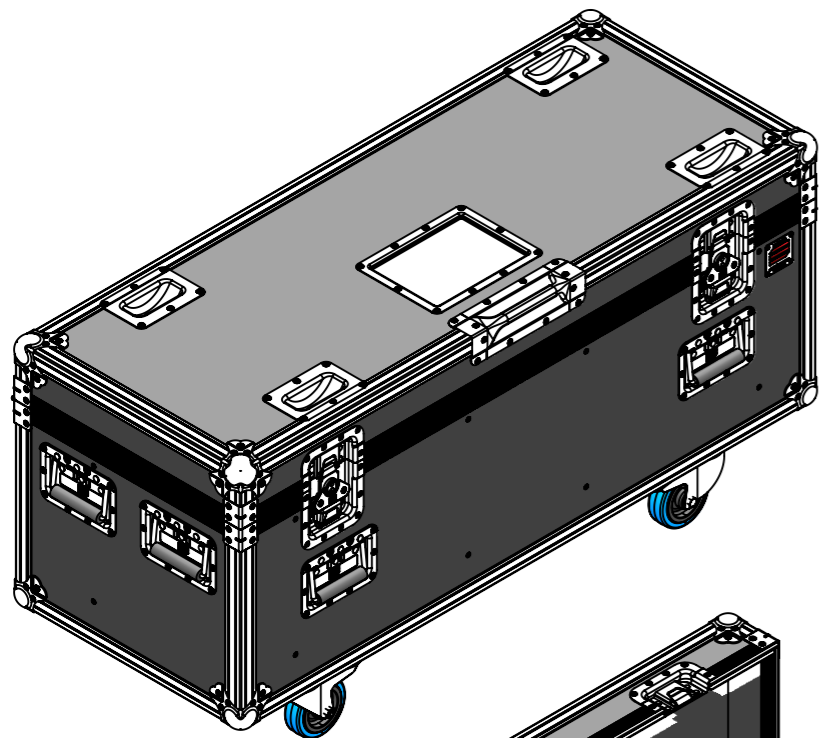