

Dimensões Interiores

Comprimento	Largura	Altura
210	437	420
Peso	Approx. 34 Kg	
Espessura	10mm	

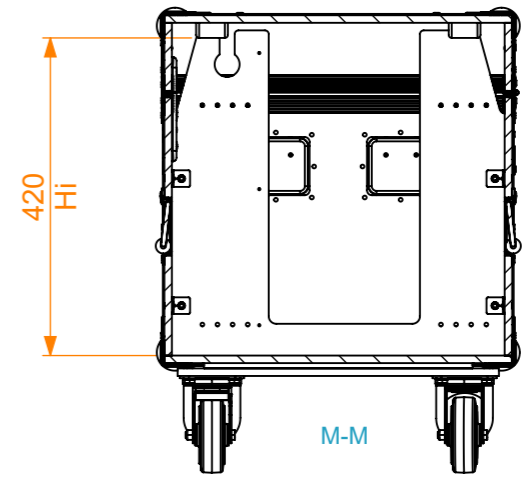
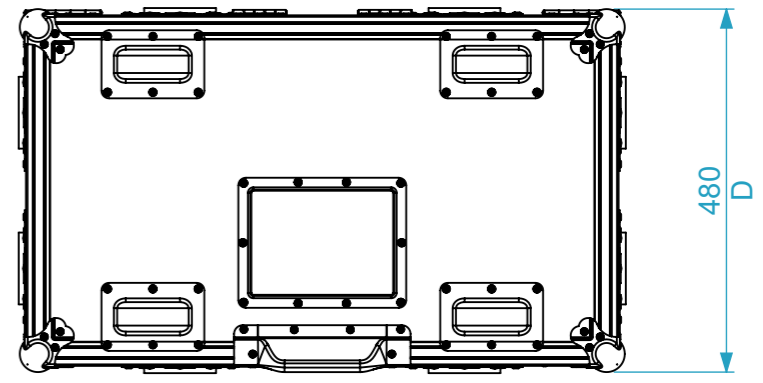
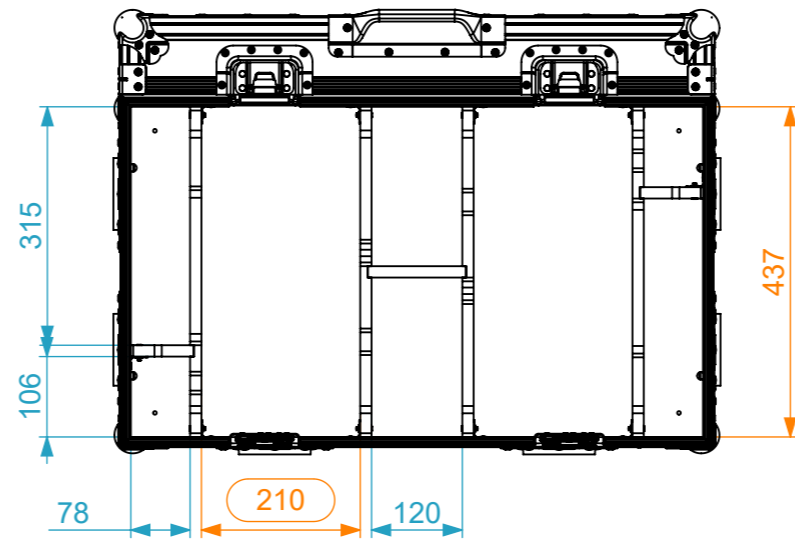
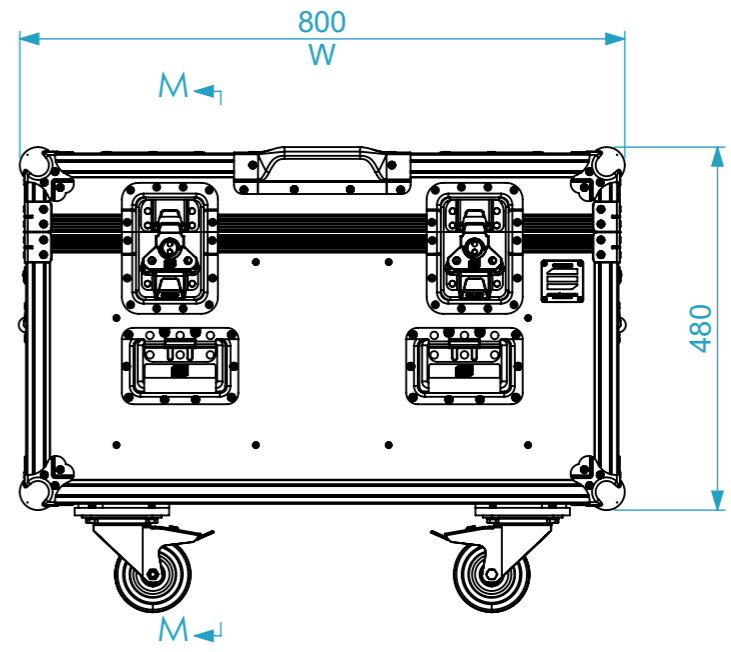
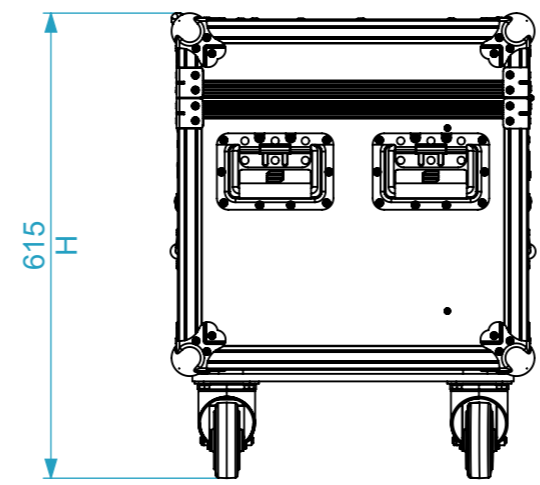
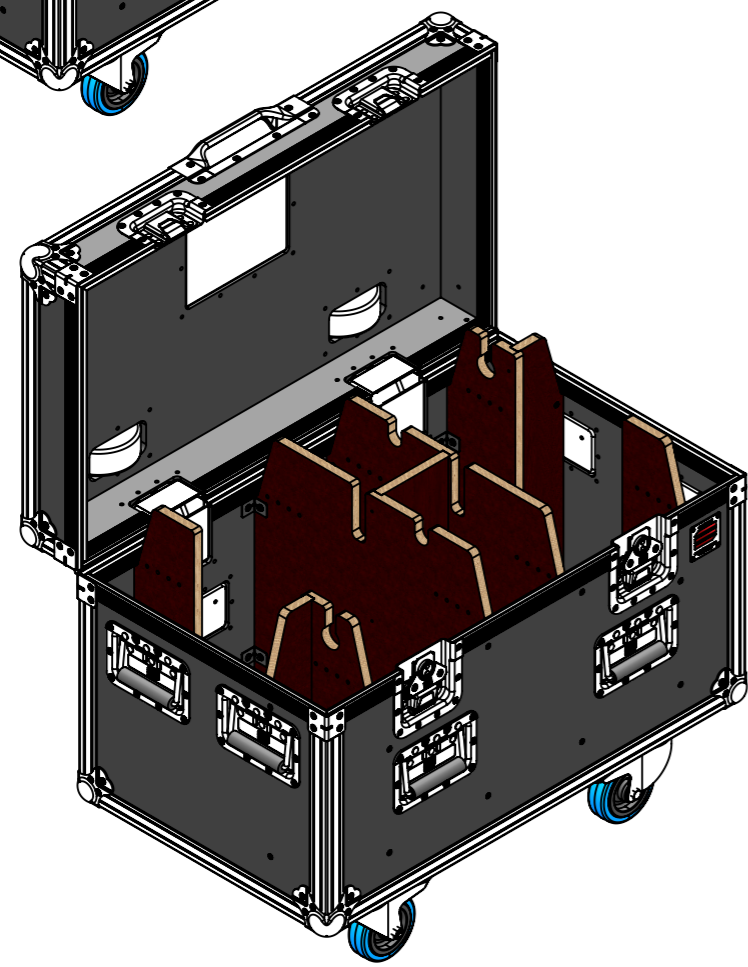
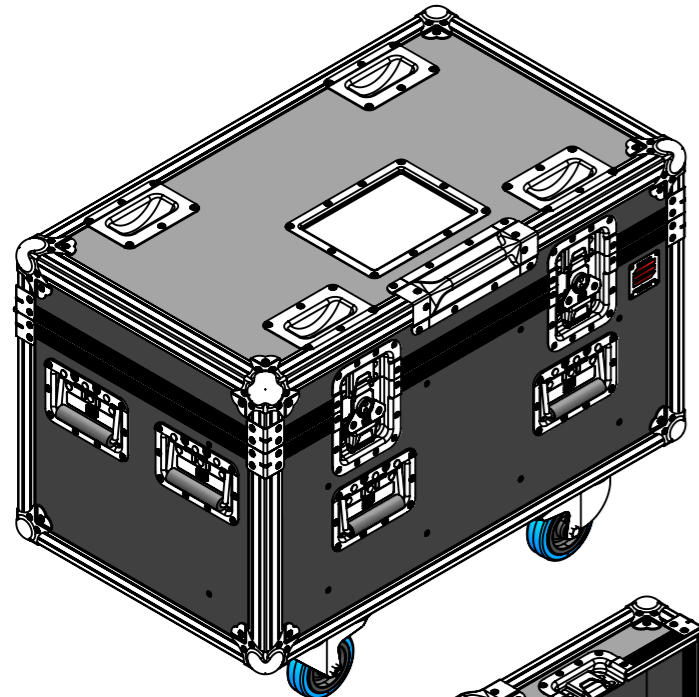

Lista de Componentes

Item nº	Quant.	Descrição	Ref.
1	1	Malão PRO, X1 80.48.48 (76x44x44 WID)	X1AAR.0804848

Drawn by	alexandre	Name	alexandre	Date	30/05/2022
Reference	RLF02.0804848B	Scale	1:10	units in mm	DO NOT SCALE
This drawing must not be copied or disclosed without consent of the owner		1st Angle projection	Scale	1:10	units in mm DO NOT SCALE
				general tolerance	0.8mm
				FC Mod, 2 Motores 436x210x420mm - Modelo 1	

