

Equipment	ChainMaster D8+ Ultra 2000 kg				
Width	450	Depth	316	Height	151
FC Weight	Approx. 37 Kg				
Wall Thickness	10mm				

ChainMaster D8+Ultra 2000 kg

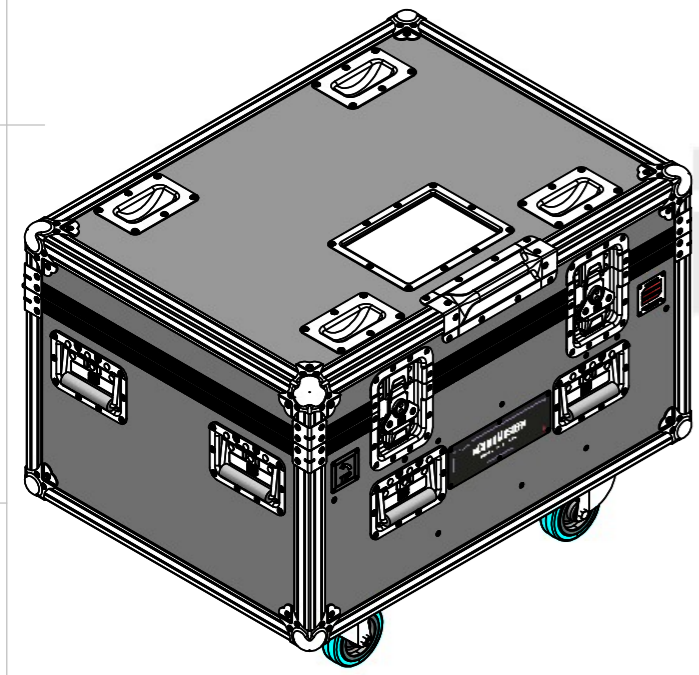

HD Foam shims

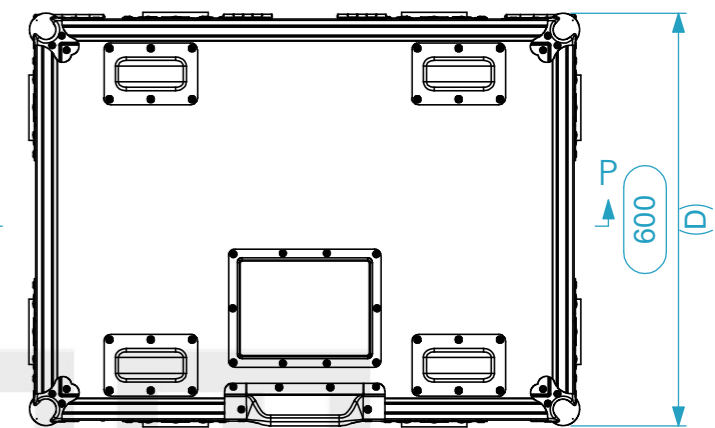
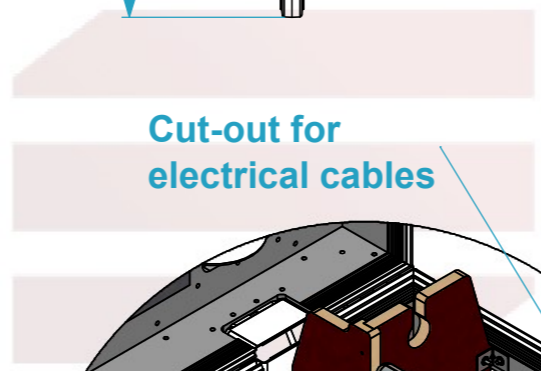
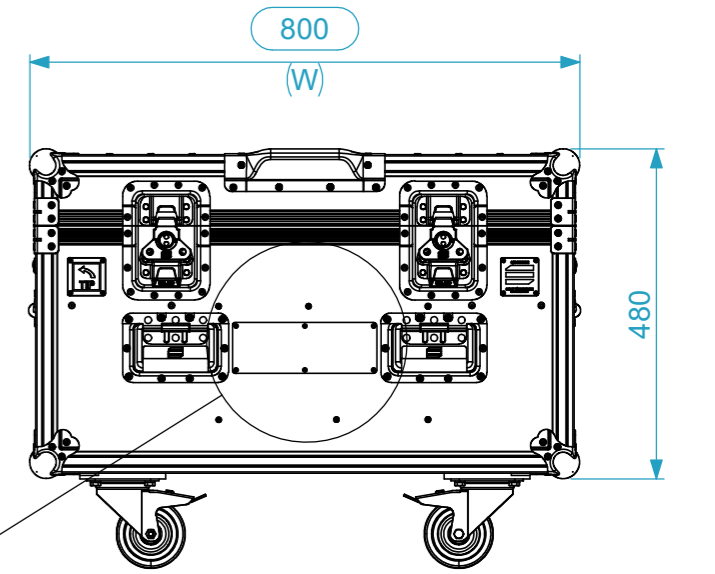
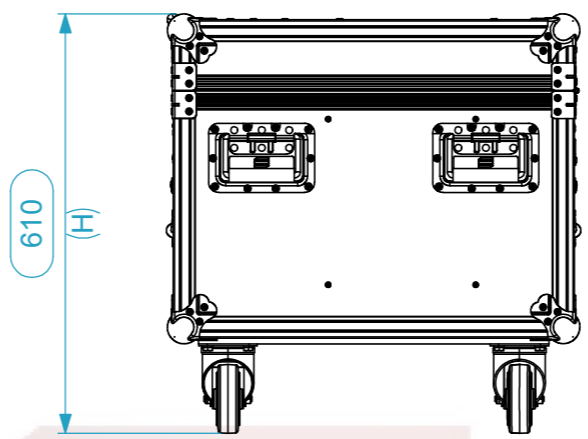
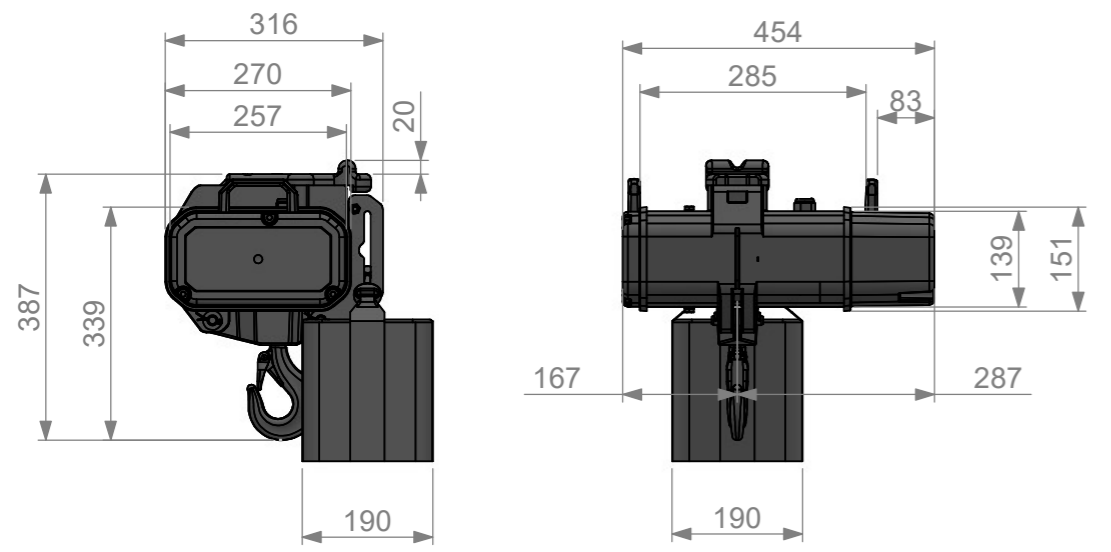
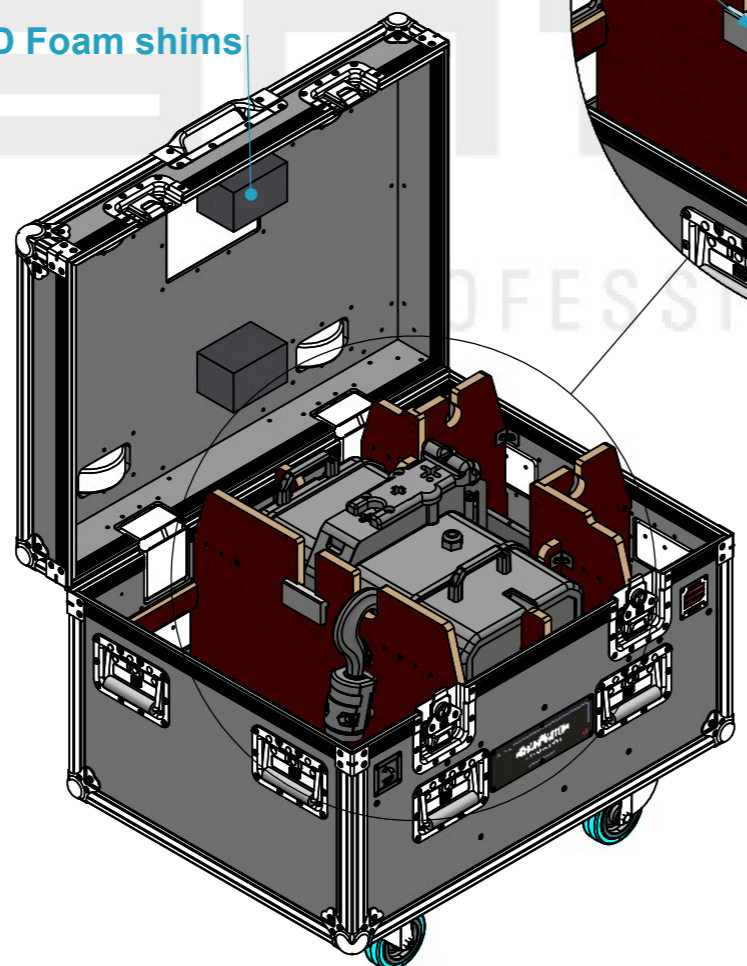

Cut-out for chain

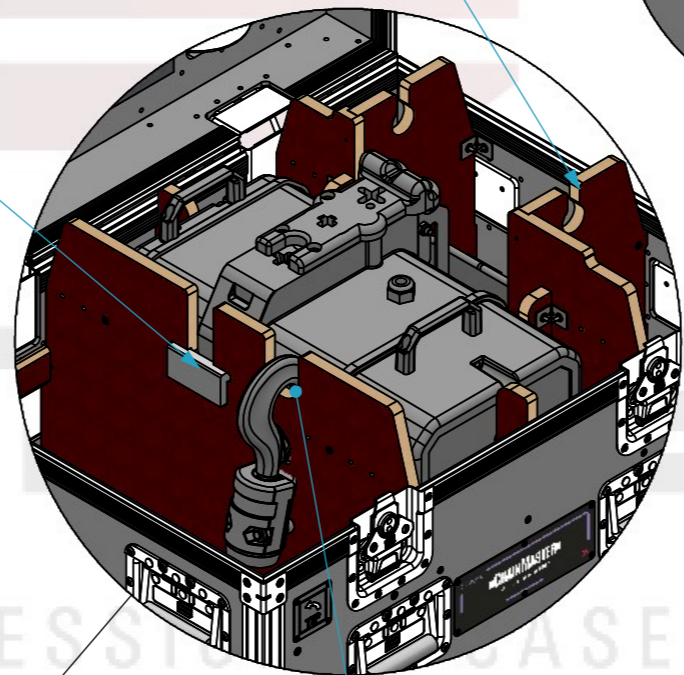

Cut-out for chain hook

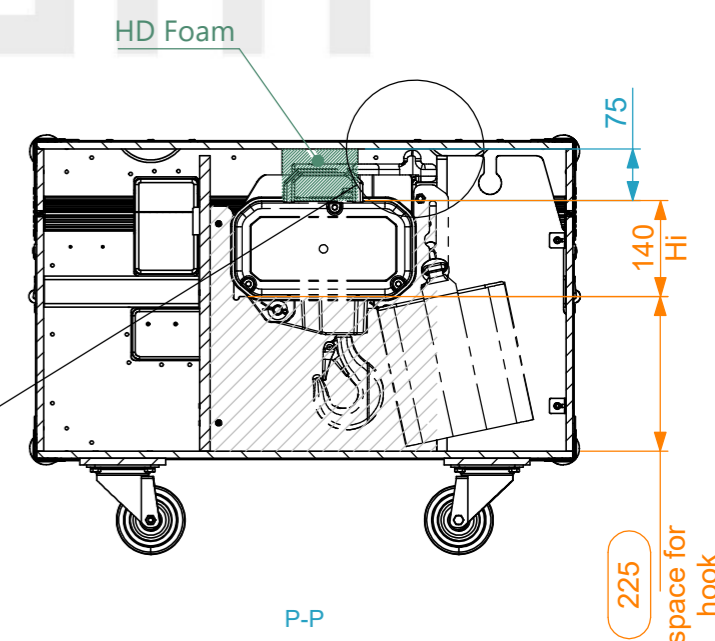
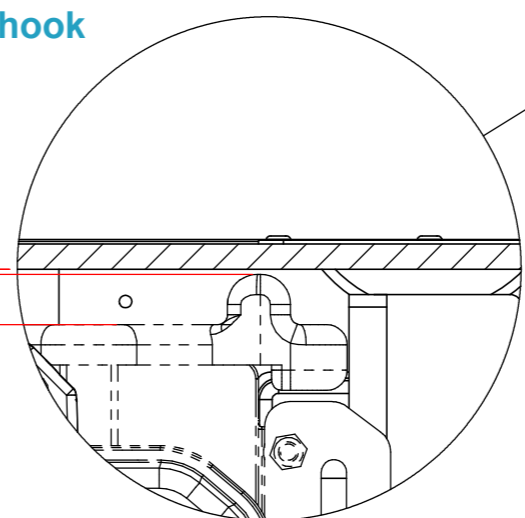

22 from lid to motor body

General External Dimensions	
W	Width
D	Depth
H	Height
Usable Inner Dimensions	
Wi	Inside Width
Di	Inside Depth
Hi	Inside Height

MORE DETAILS IN THE NEXT PAGE

This drawing must not be copied or disclosed without consent of the owner

Drawn by	jose.coufo	Date	01/04/2025
Reference	RL1.CHMU2T.01		
Scale	1:11	units in mm	general tolerance 0.8mm
1st Angle projection	Flight case PRO. 1x ChainMaster D8+ Ultra 2T		



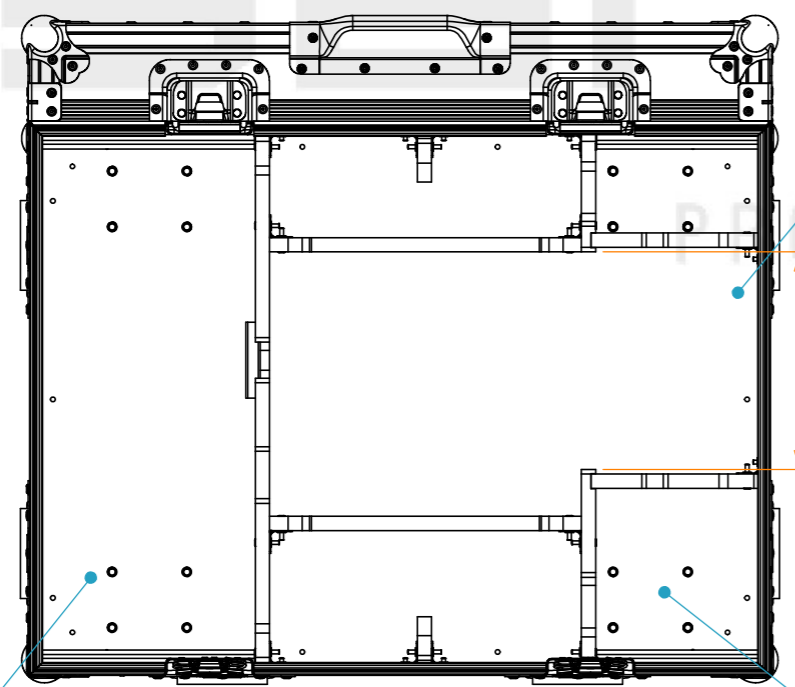
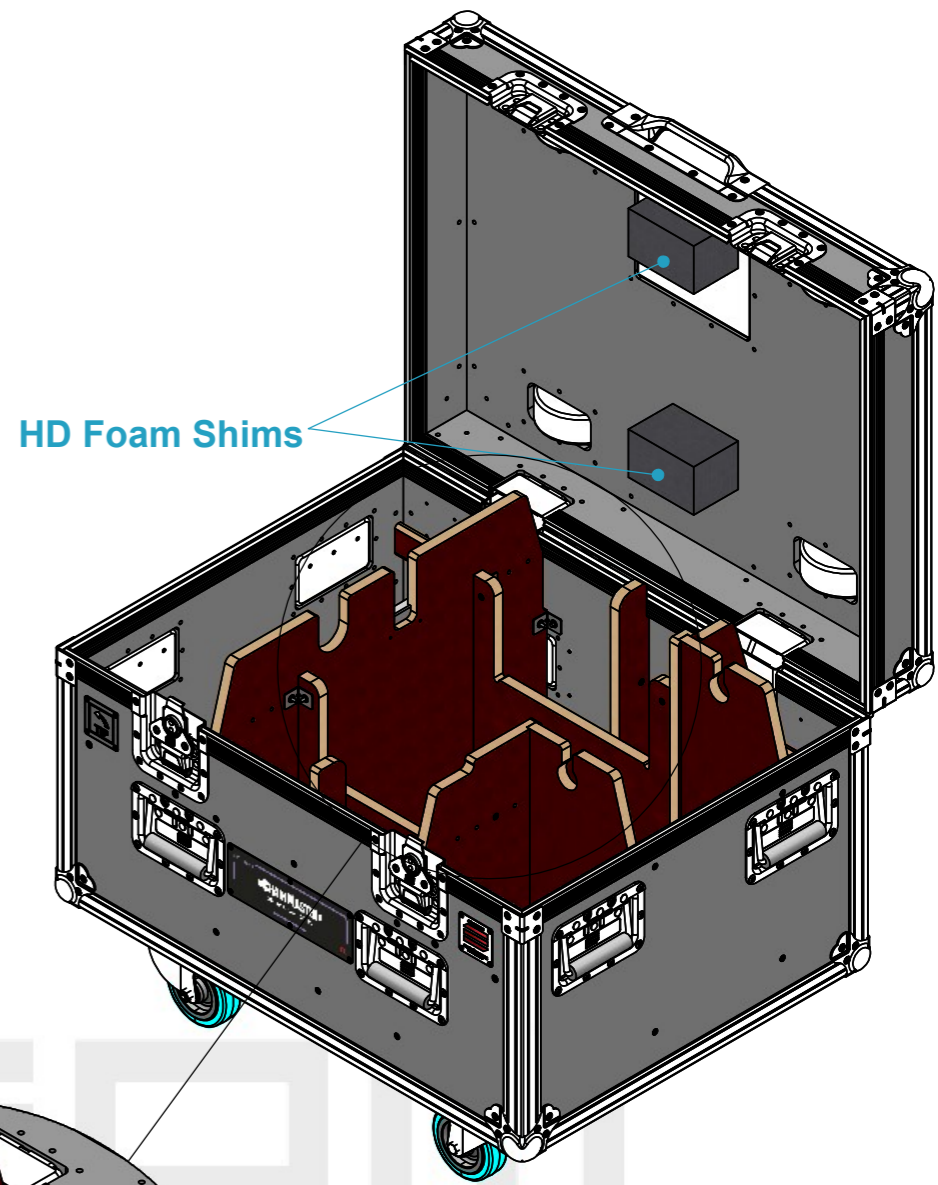
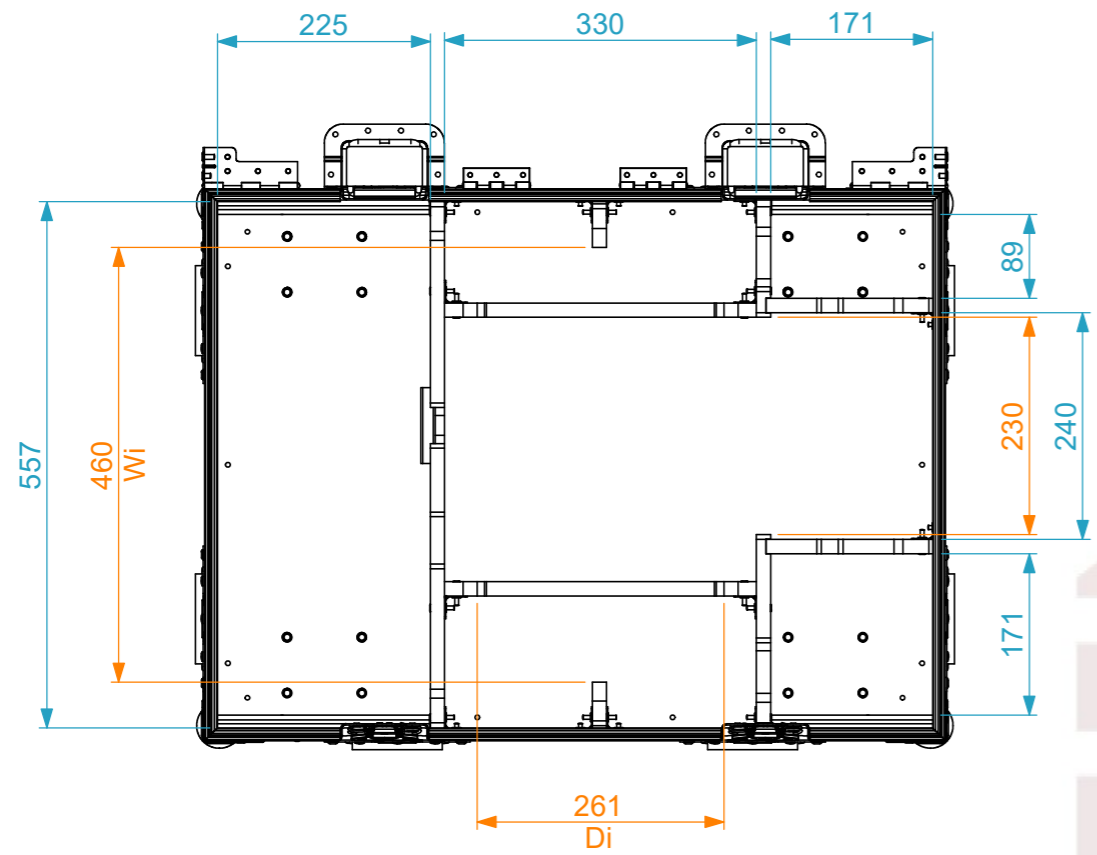

Compartments for hoist chain

Compartment for electrical cables and socket

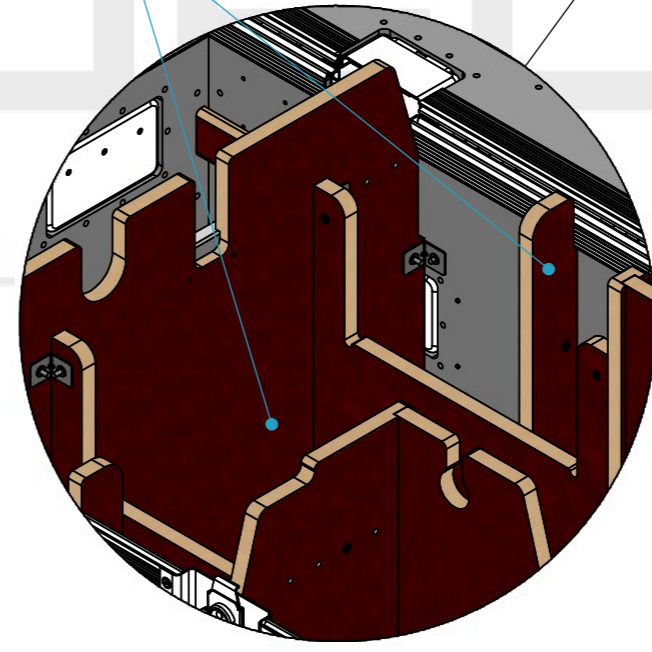

Drawn by	Name	Date
jose.couto	jose.couto	01/04/2025
Reference	RL1.CHMU2T.01	
Scale	units in mm	general tolerance
1:11	DO NOT SCALE	0.8mm
Flight case PRO. 1x ChainMaster D8+ Ultra 2T		



This drawing must not be copied or disclosed without consent of the owner



A3