

Interior dimensions

Width	Depth	Height
497	442	94
Weight	Approx. 10.92 Kg	
Wall Thickness	4.5mm	

REVISIONS

ZONE	REV.	DESCRIPTION	DATE	APPROVED
-	0	Final Drawing	11/06/2013	Telmo Santos
-	1	Updated Drawing	17/09/2013	Daniel Lopes
-	2	Changed the interior design	18/02/2014	Daniel Lopes

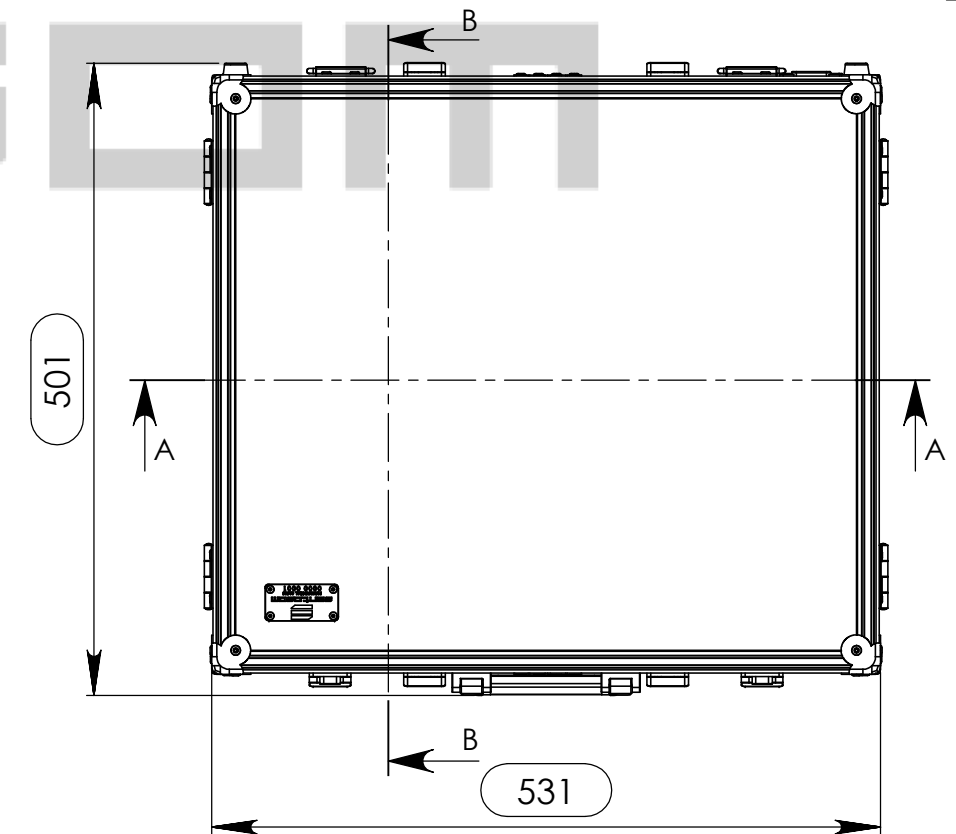
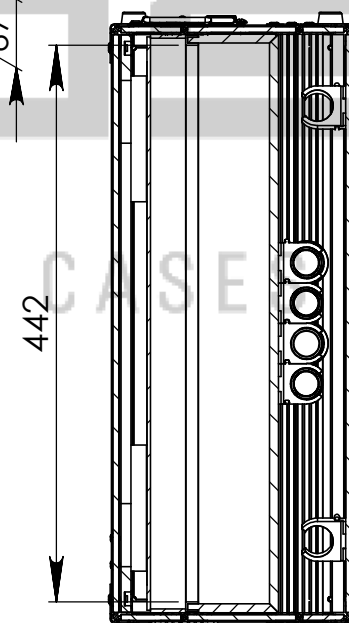
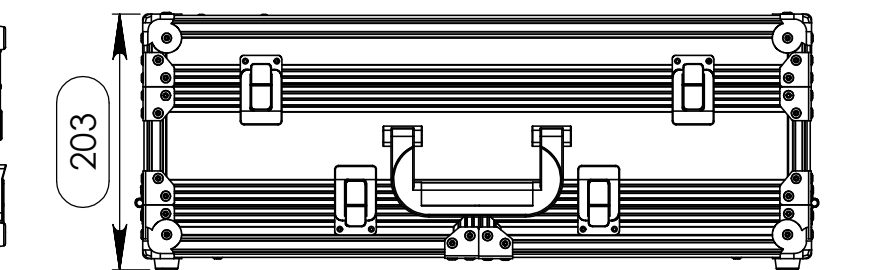
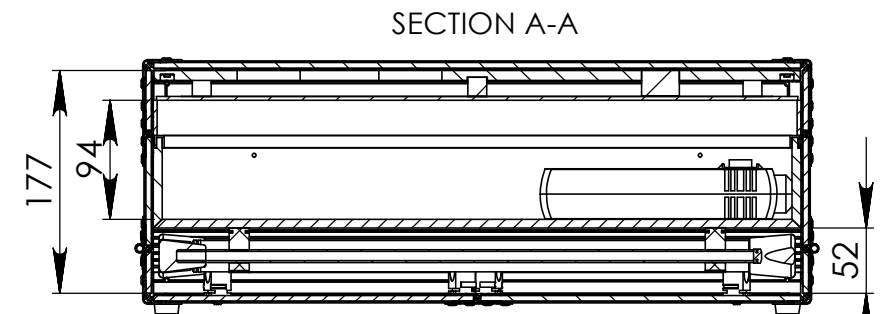
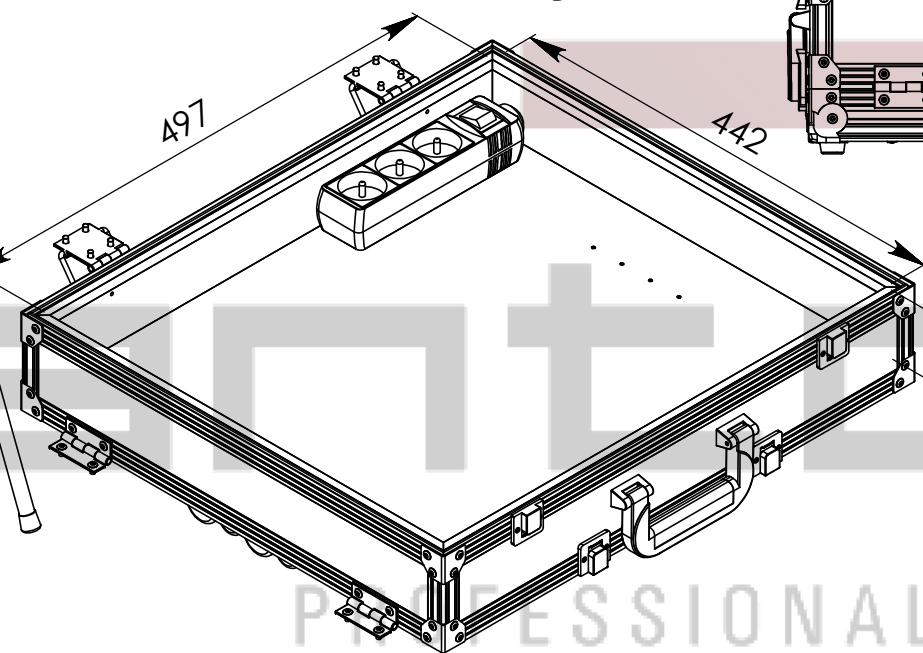
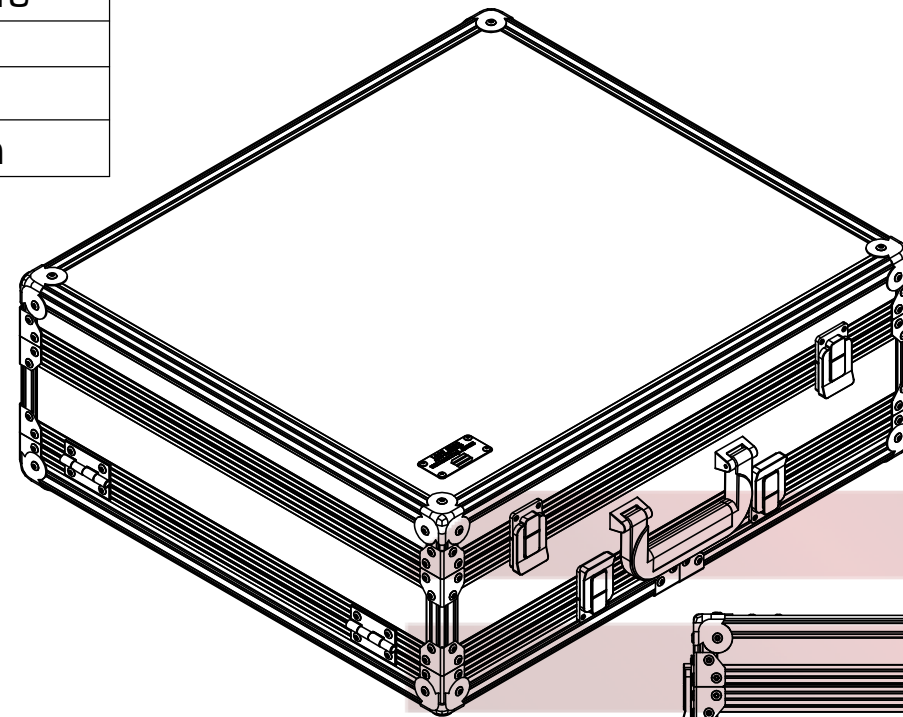
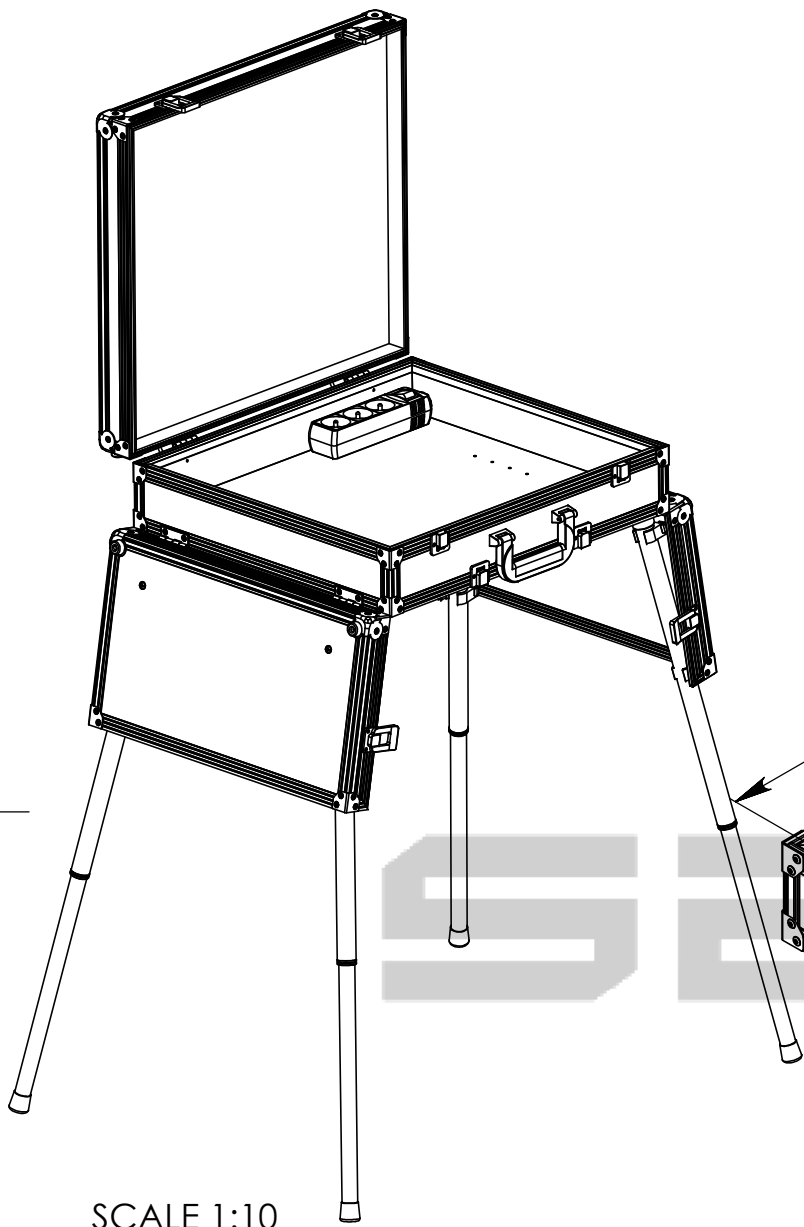

SCALE 1:10

Hardware

Qty	Ref.	Description
8	4056	Small case corner - 3 leg - 1 mm Steel, chrome plated
20	4046	Small corner brace - suits 6136 casemaker
8	4903	Rubber foot 20 x 9 mm, black
1	3430	Chrome plated plastic with soft black plastic insert
2	2524	Heavy Duty Strut Hinge, zinc plated
1	CEC.002	IEC MALE PANEL PLUG
4	2601	Hinge small 1,3 mm Steel zinc plated
6	1619	Simple block catch

SECTION B-B

This drawing must not be copied or disclosed without consent of the owner

Drawn by	Name	Date
DanielLopes	DanielLopes	18-02-2014
Reference	STAR.0503	
Scale	units in mm	general tolerance
1:6	DO NOT SCALE	0.8mm
FC. MAKE UP P/ KIT PÉS 500X450X130+50. LUZ LED		

