

**Internal Dimensions**

<b>Width</b>	<b>Depth</b>	<b>Height</b>
1156	556	420
<b>Weight</b>	Approx. 38 Kg	
<b>Wall Thickness</b>		10mm

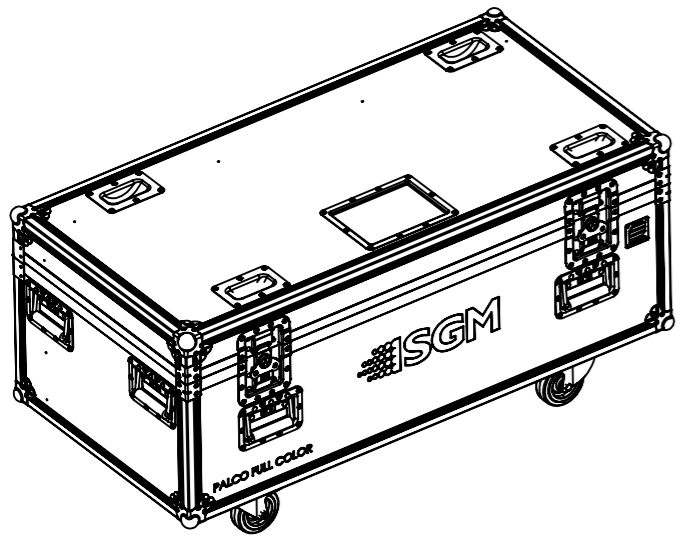

SGM Placo 5

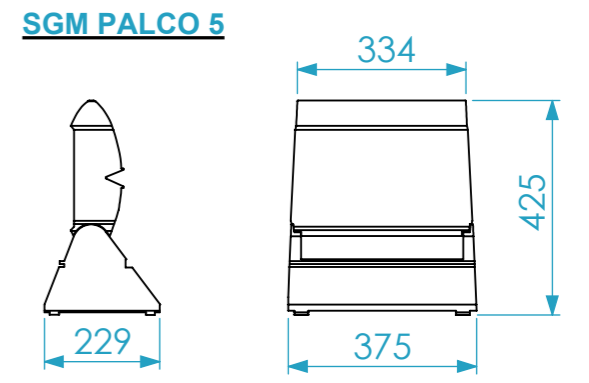
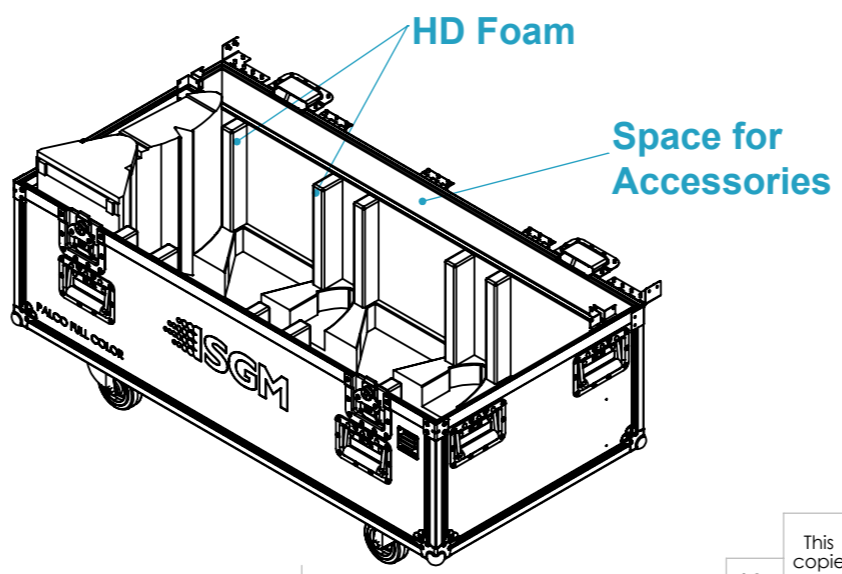
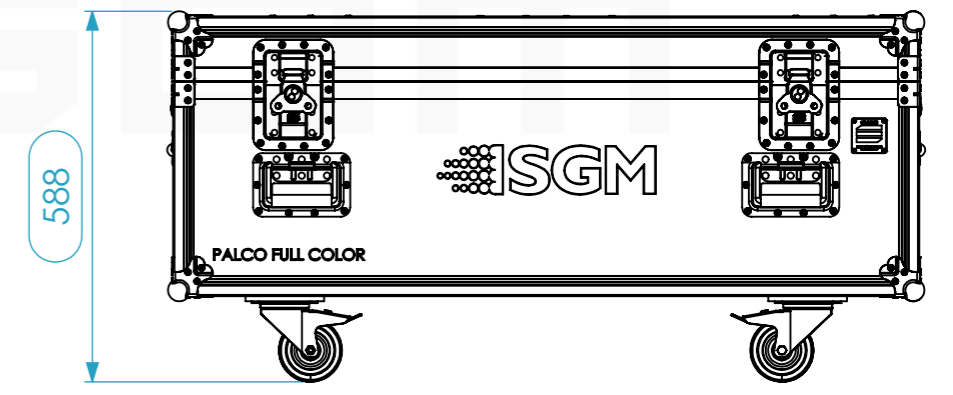
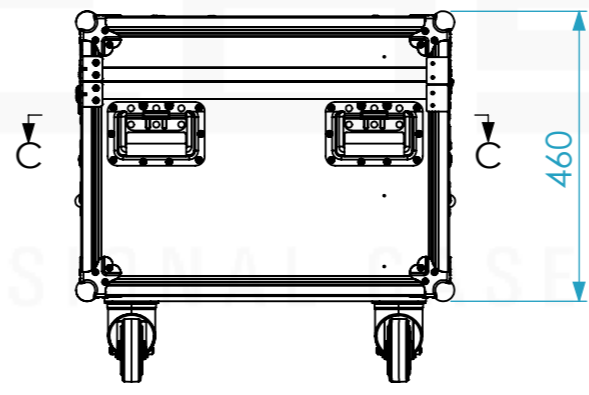
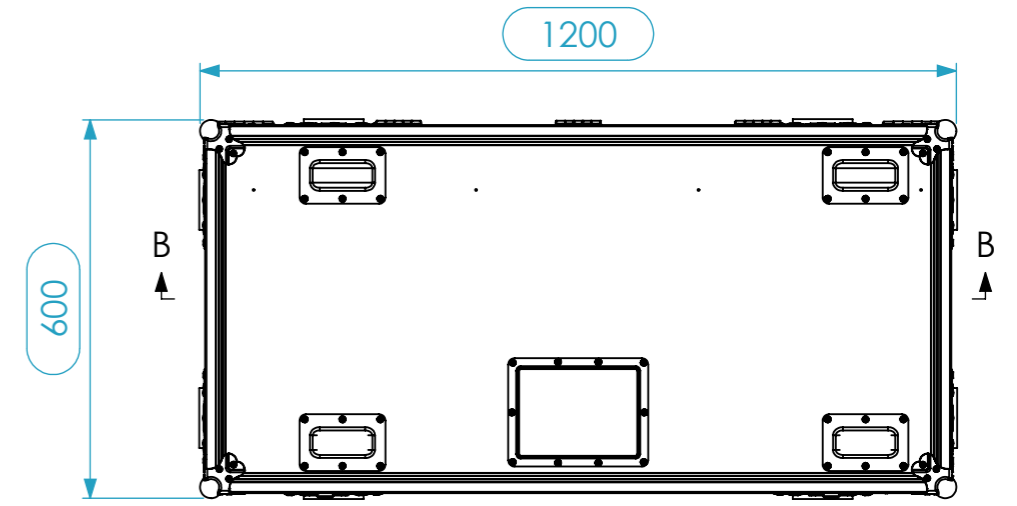
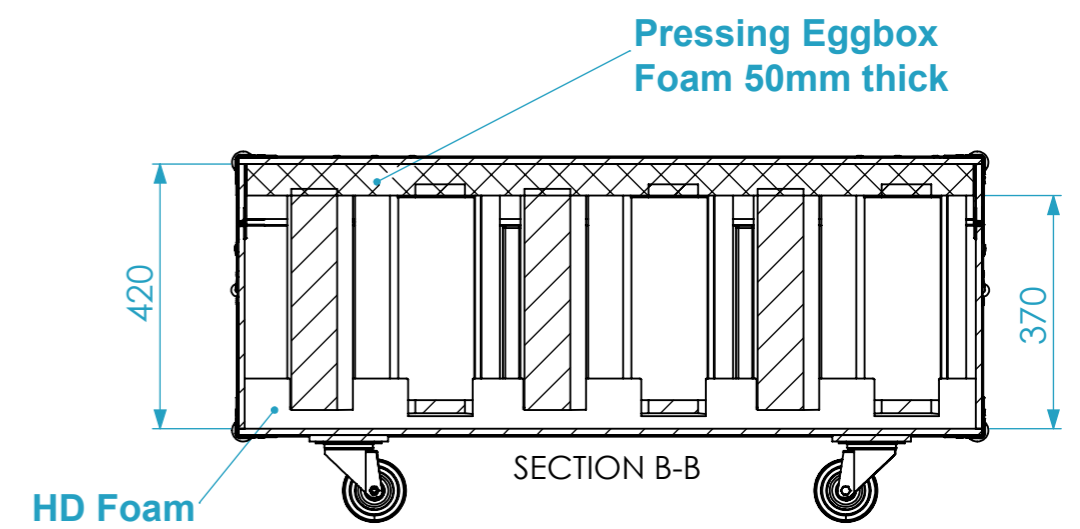
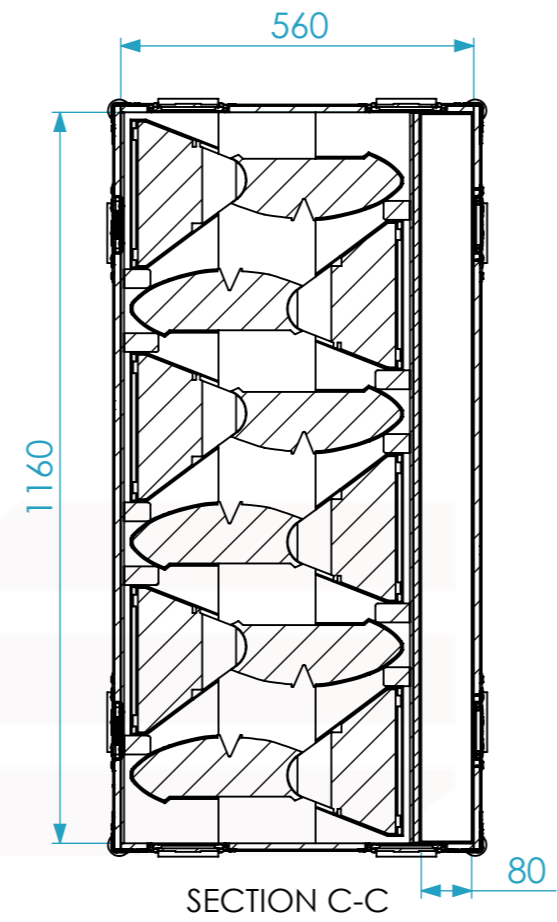
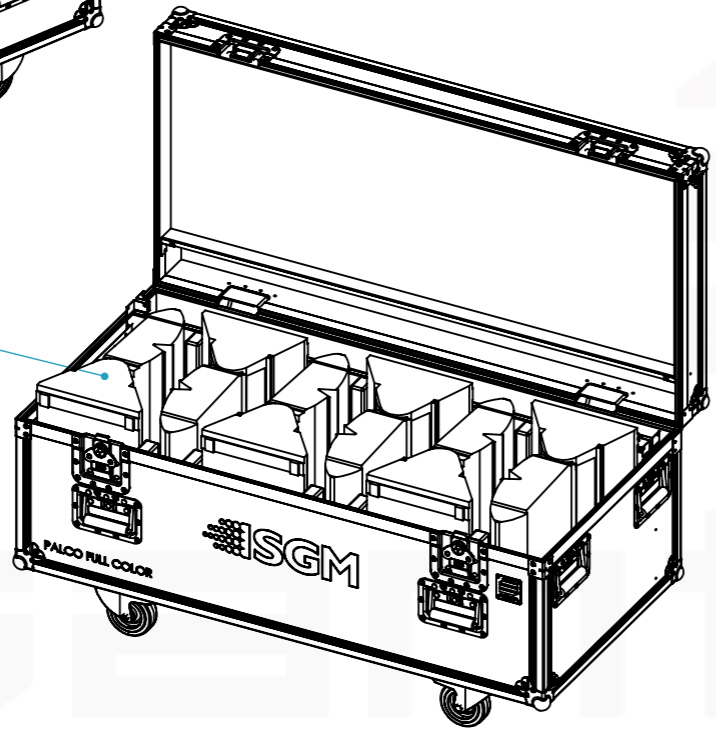

Hardware		
Qty	Ref.	Description
4	40403	Large corner bracket f. 35mm case angle
8	410429	Heavy Duty Ball Corner
1	88001D	Dish for 88001 Tour Label
1	CHAPA.1000	Identification Plate
2	172511PEN	Butterfly Latch large cranked 14 mm deep - MOL-compatible
2	270836	Large lidstay cranked / hinge
2	RODA.100T	Swivel castor Ø100mm with brake
2	RODA.100	Swivel castor Ø100 mm
4	38083	Castor dish deep zinc plated
2	DCR110	Combination of Hinge and 2 Corner Braces
3	2602	Medium duty butt hinge z./p.
8	34082	Recessed Sprung Handle Medium
4	4292	Bracket for dividing walls

This drawing must not be copied or disclosed without consent of the owner

Drawn by	Name	Date
jorgepacheco	jorgepacheco	02/02/2018
Reference	PROJET.663R	
Scale	units in mm	general tolerance
1:12	DO NOT SCALE	0.8mm
1st Angle projection	FC. 6X SGM PALCO 5 RODAS	

