

Equipment	CLF LEDWASH RGBW	
Width	Depth	Height
485	145	105
Internal Dimensions		
Width	Depth	Height
106	146	485-9
Weight	Approx. 40 Kg	
Wall Thickness	10mm	

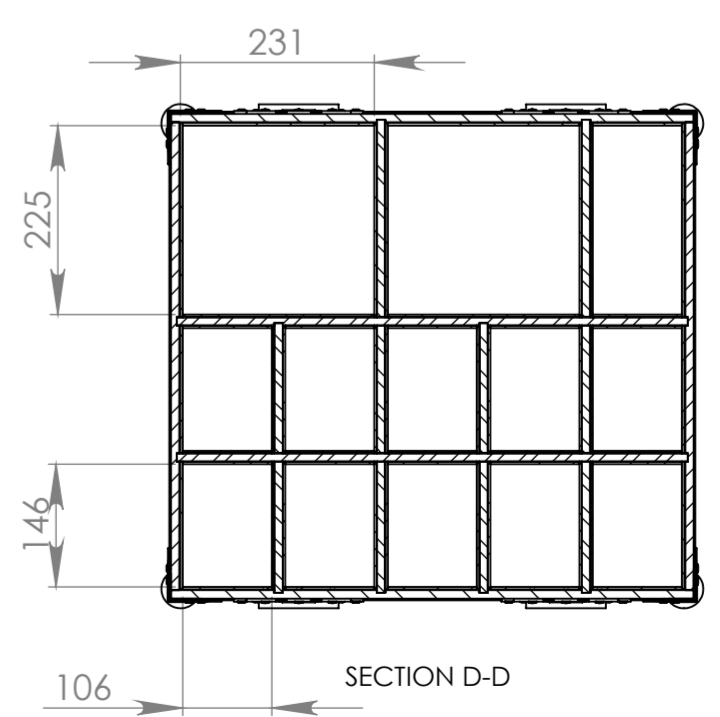
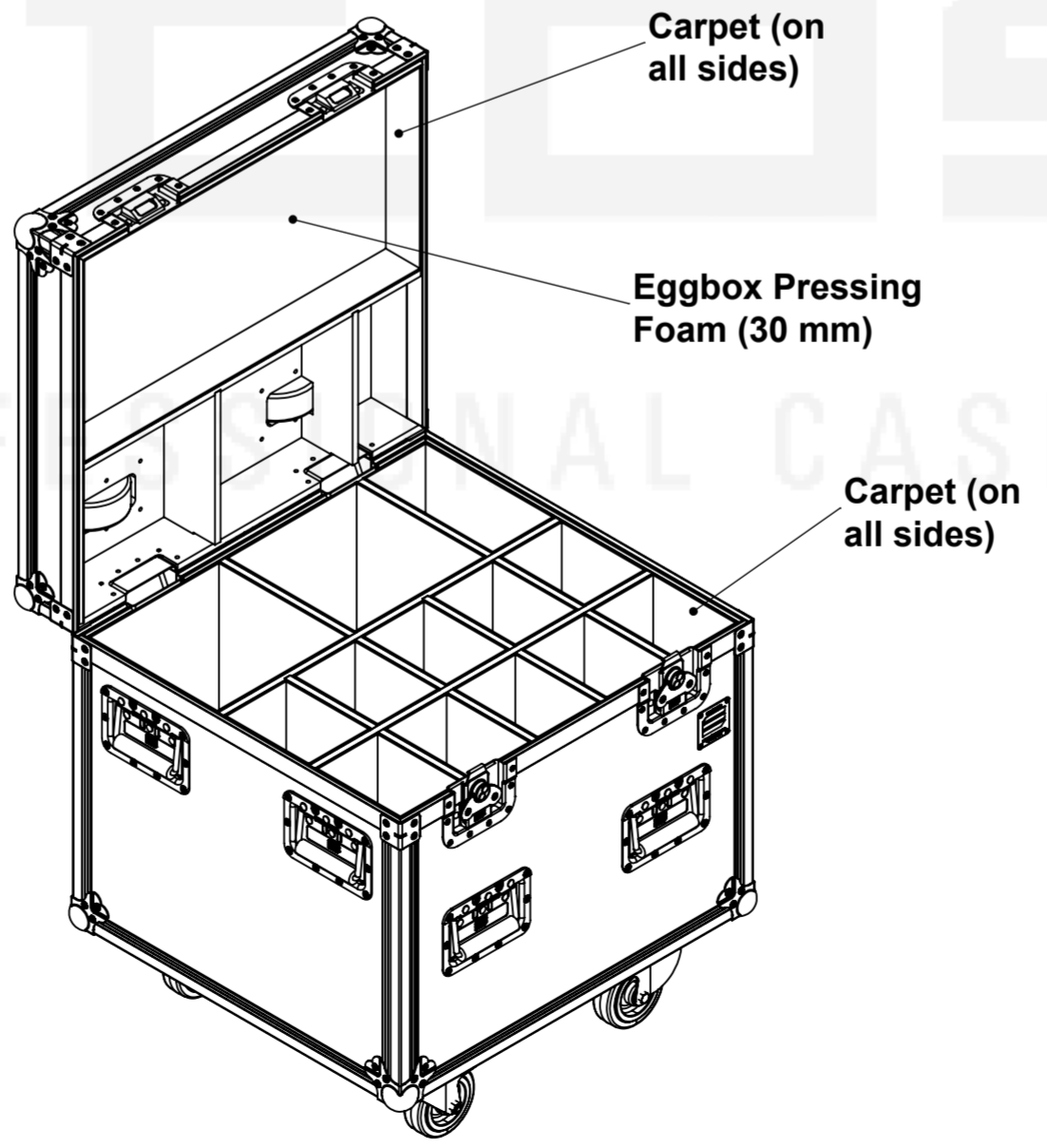
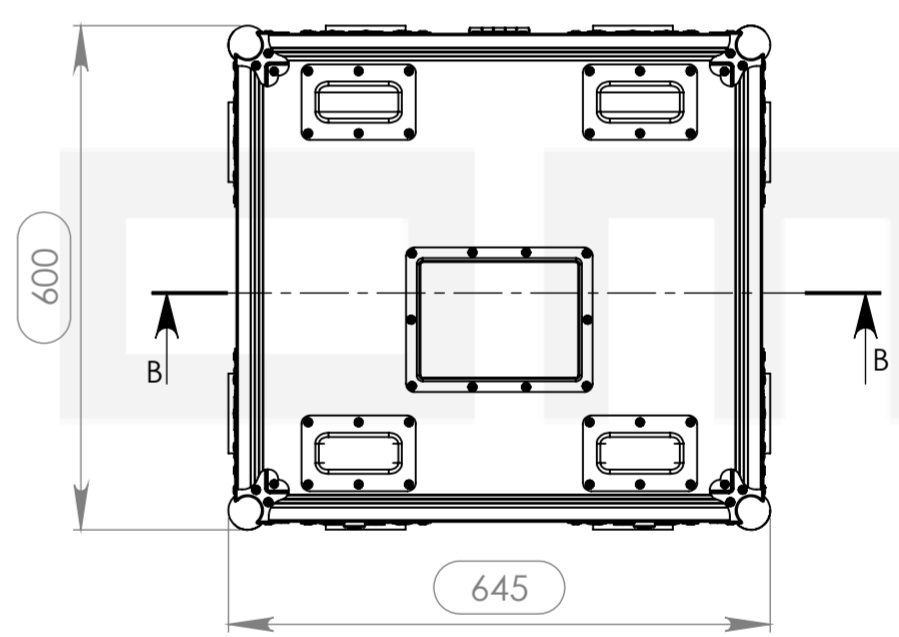
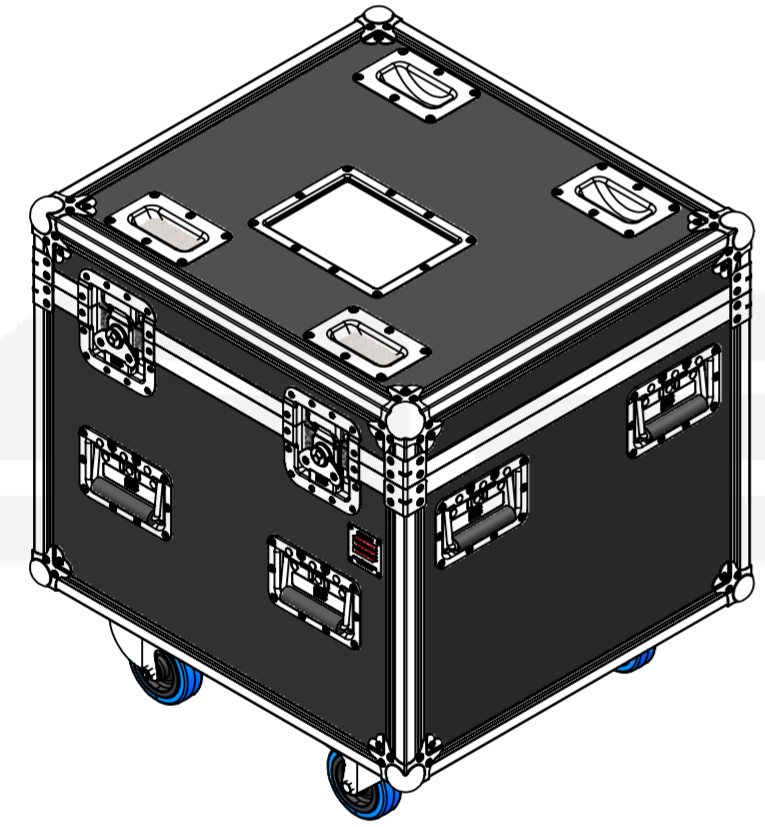
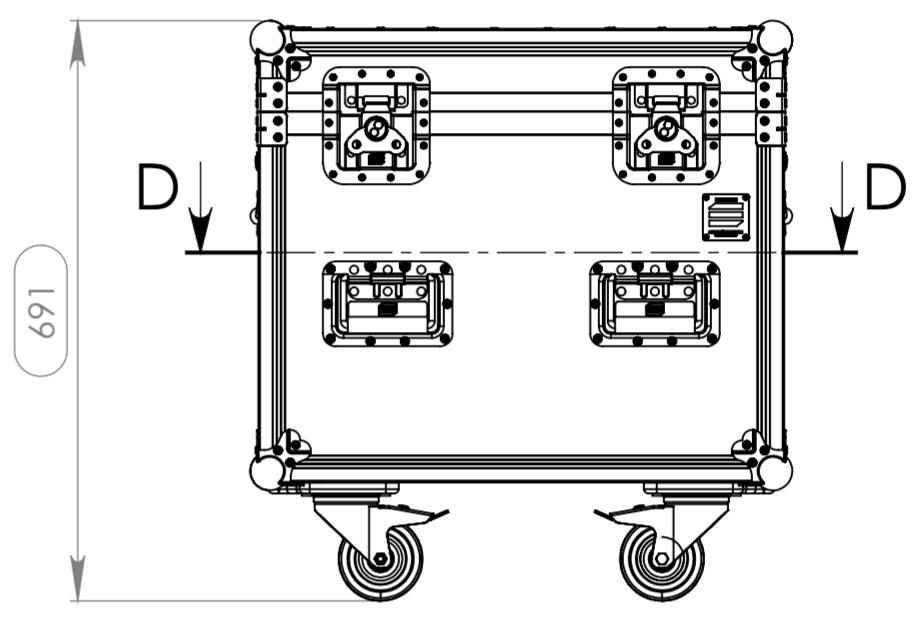
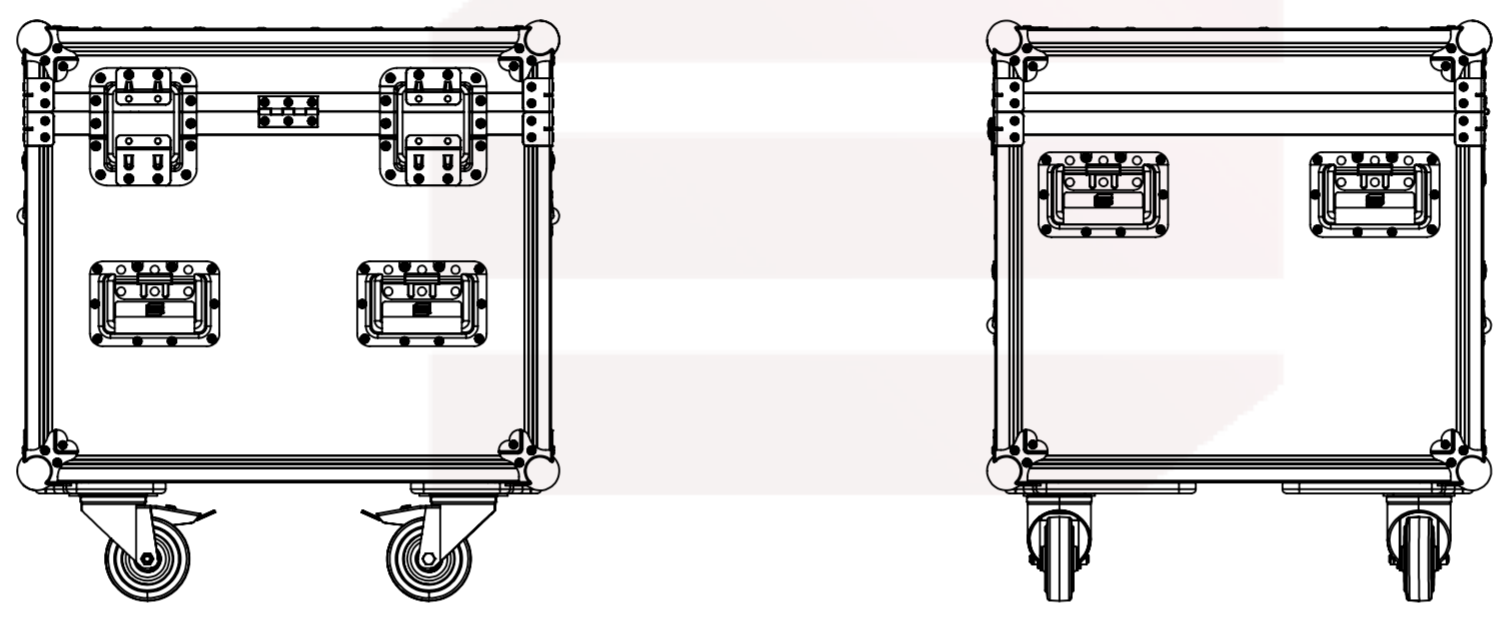
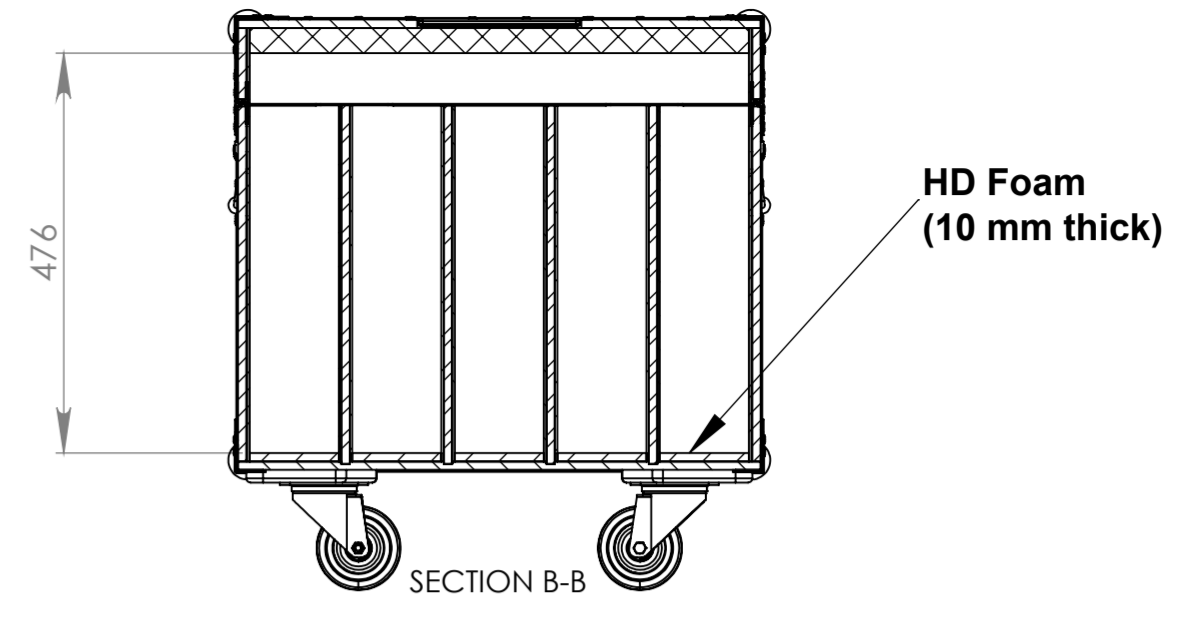

Hardware		
Qty	Ref.	Description
8	410429	Ball Corner large three-leg cranked 35 mm 9 holes
8	40403	Large corner bracket f. 35mm case angle
8	34082	Recessed sprung handle medium model
1	88001D	Dish for 88001 Tour Label
2	RODA.100T	Swivel castor Ø100mm with brake
2	RODA.100	Swivel castor Ø100 mm
2	172531	Large butterfly V3 with 'push-back' function
4	38083	Castor dish deep zinc plated
1	2602	Medium duty butt hinge z./p.
2	270736	Short recessed lidstay cranked
1	CHAPA.1000	Identification Plate

Drawn by	alexandre	Date	25/10/2016
Reference	PROJET.296R		
Scale	1:9	units in mm	general tolerance 0.8mm
DO NOT SCALE			

This drawing must not be copied or disclosed without consent of the owner

1st Angle projection

FLUHCASE_10X CLF LEDWASH RGBW

SANTOSOM

PROFESIONALES CASAS