

Interior dimensions		
Width	Depth	Height
275	255	760
Weight	Approx. 55 Kg	
Wall Thickness	10mm	

REVISIONS				
ZONE	REV.	DESCRIPTION	DATE	APPROVED
-	0	Final Drawing	04/08/2016	Alexandre

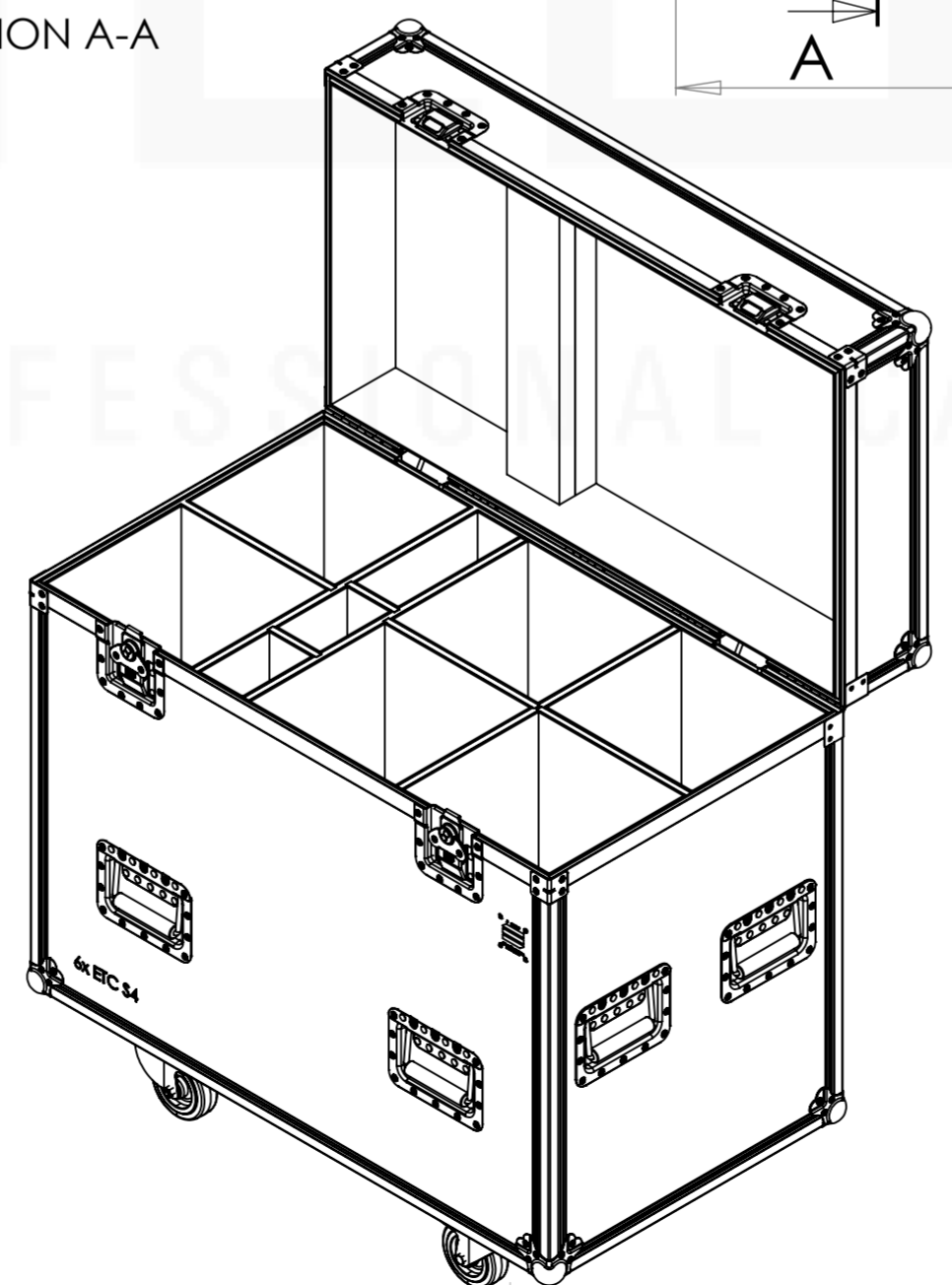
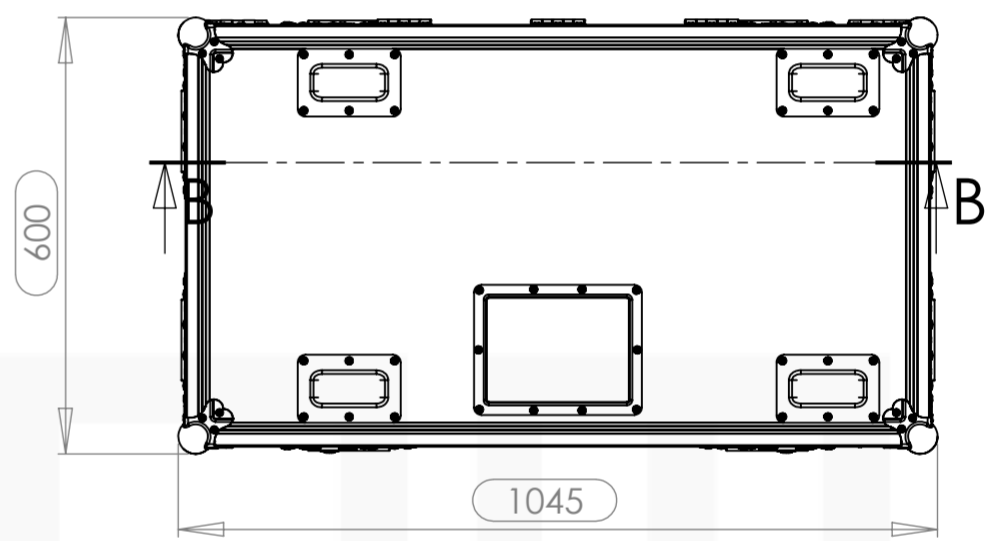
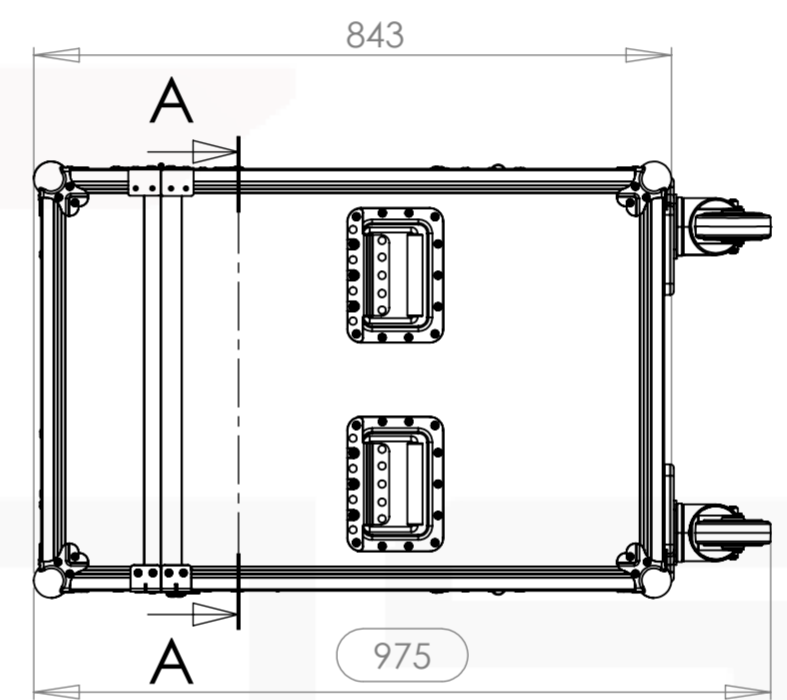
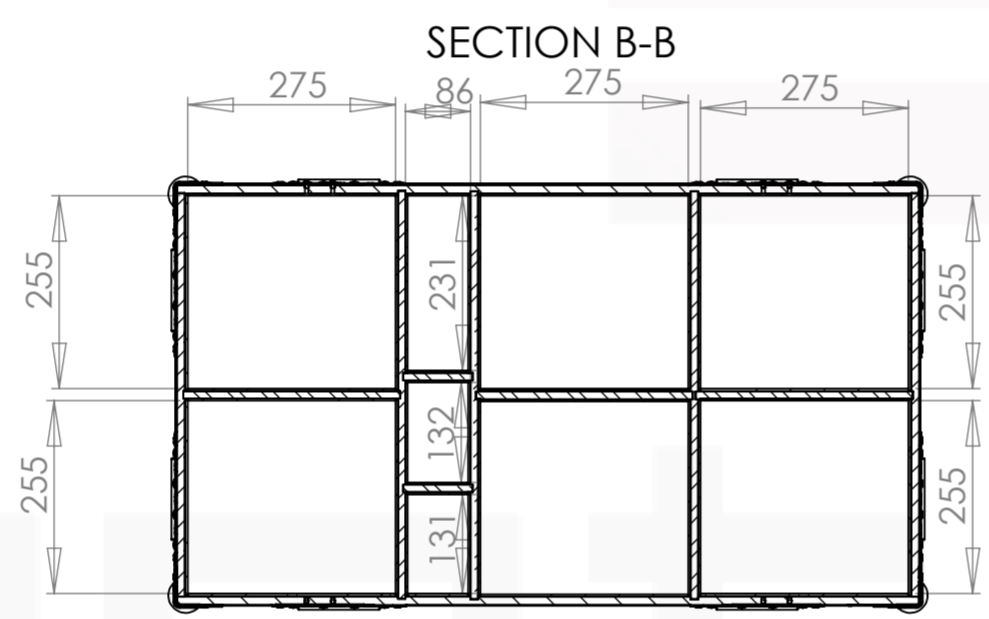
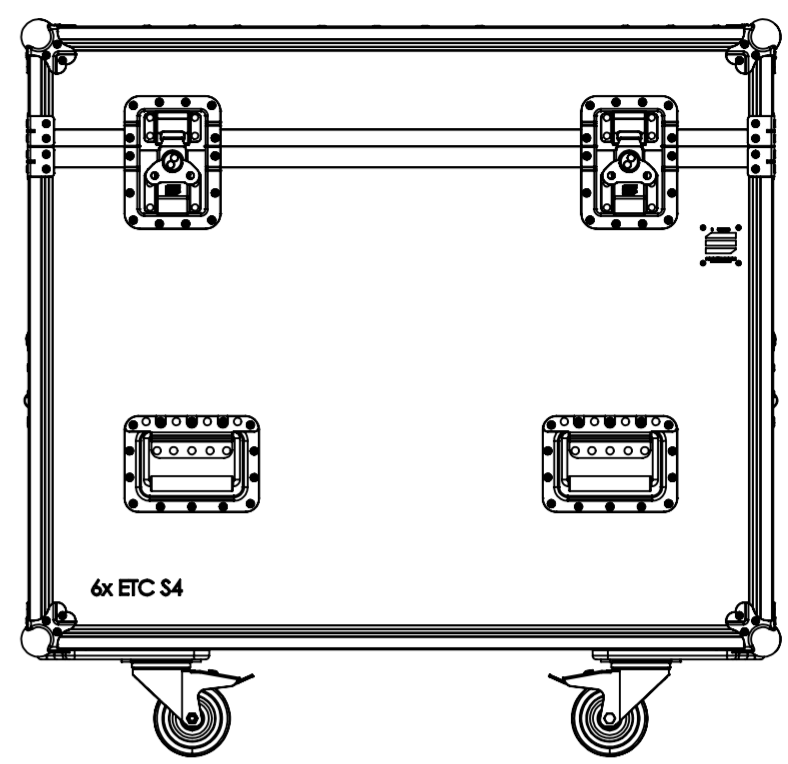
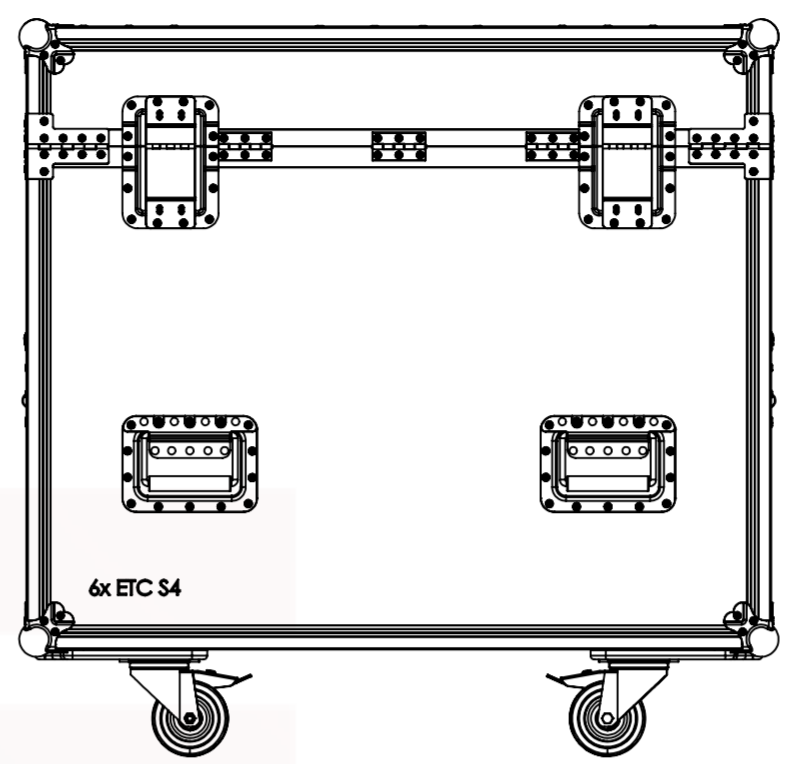
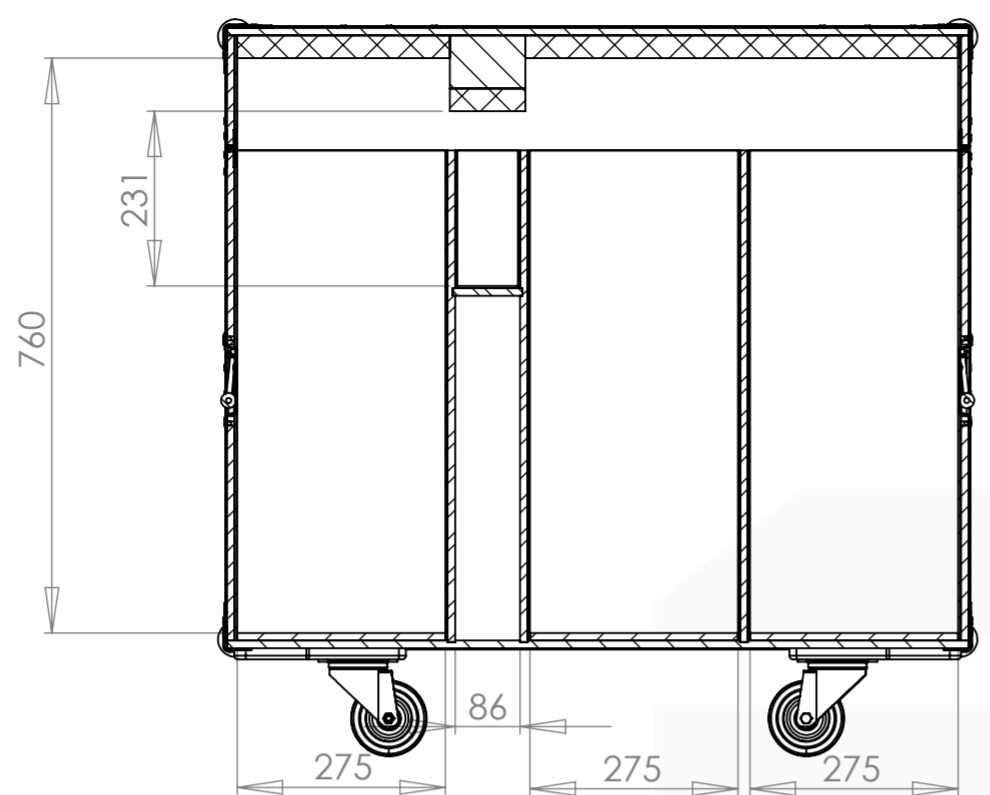
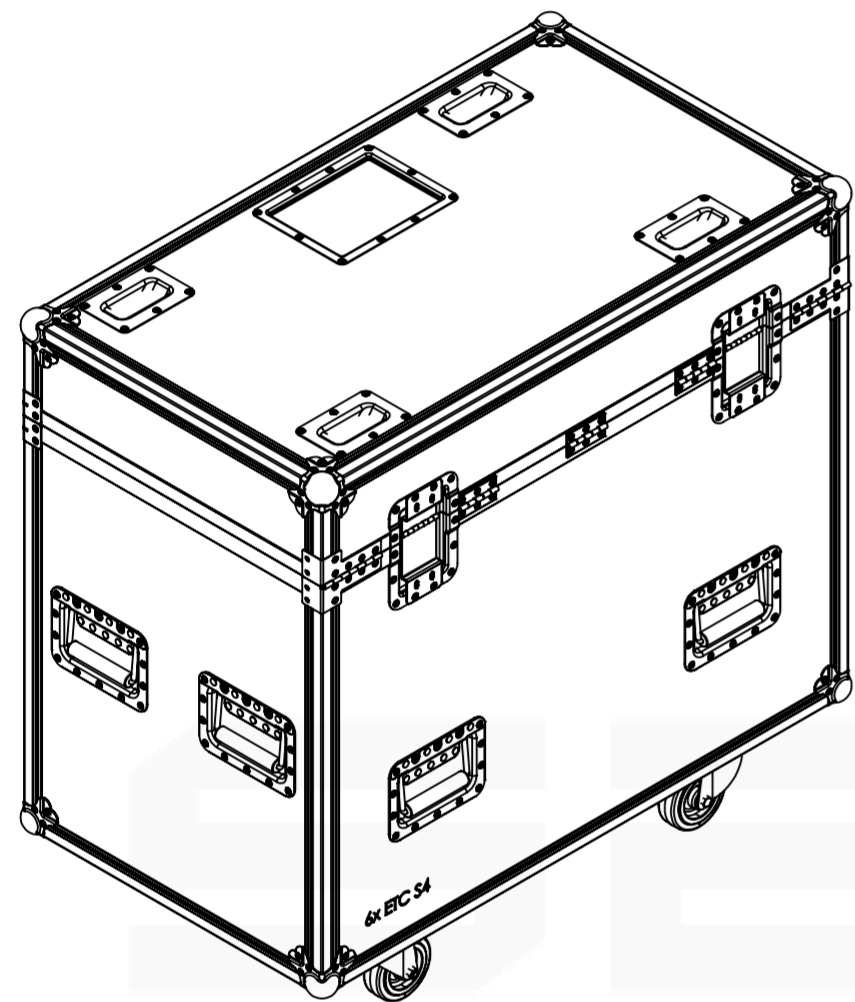

Hardware		
Qty	Ref.	Description
4	40403	Large corner bracket f. 35mm case angle
8	410429	Heavy Duty Ball Corner
1	88001D	Dish for 88001 Tour Label
1	CHAPA.1000	Identification Plate
4	38083	Castor dish deep zinc plated
8	34085	Large, heavy duty, recessed sprung handle
2	172511COMP	Large AH butterfly with 'push-back', 14mm dish
2	270836	Large lidstay cranked / hinge
2	DCR110	110MM hinge shot
3	2602	Medium duty butt hinge z./p.
2	RODA.100T	Swivel castor Ø100mm with brake
2	RODA.100	Swivel castor Ø100 mm

Drawn by	alexandre	Date	04/08/2016
Reference	PROJET.127		
Scale	1:10	units in mm	general tolerance 0.8mm
1st Angle projection			

This drawing must not be copied or disclosed without consent of the owner

PROJET.127 14-210