

Internal Dimensions		
Width	Depth	Height
962	72	962
Weight	Approx. 59 Kg	
Wall Thickness		10mm

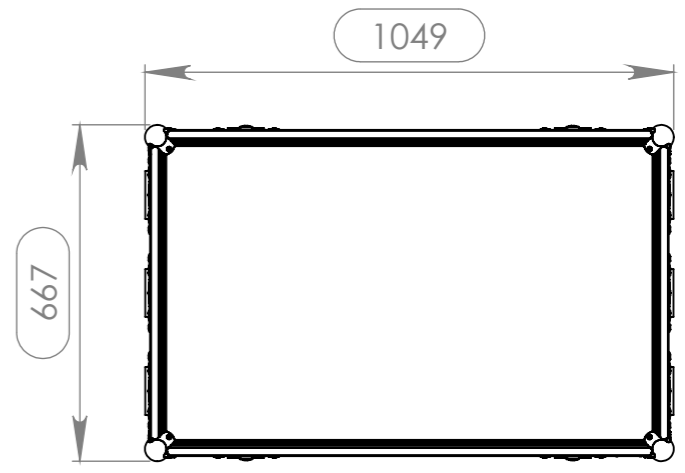
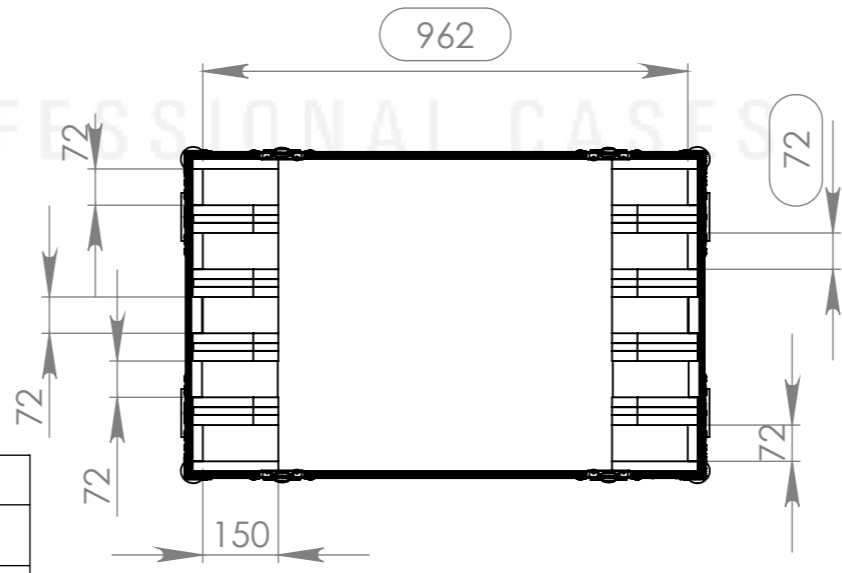
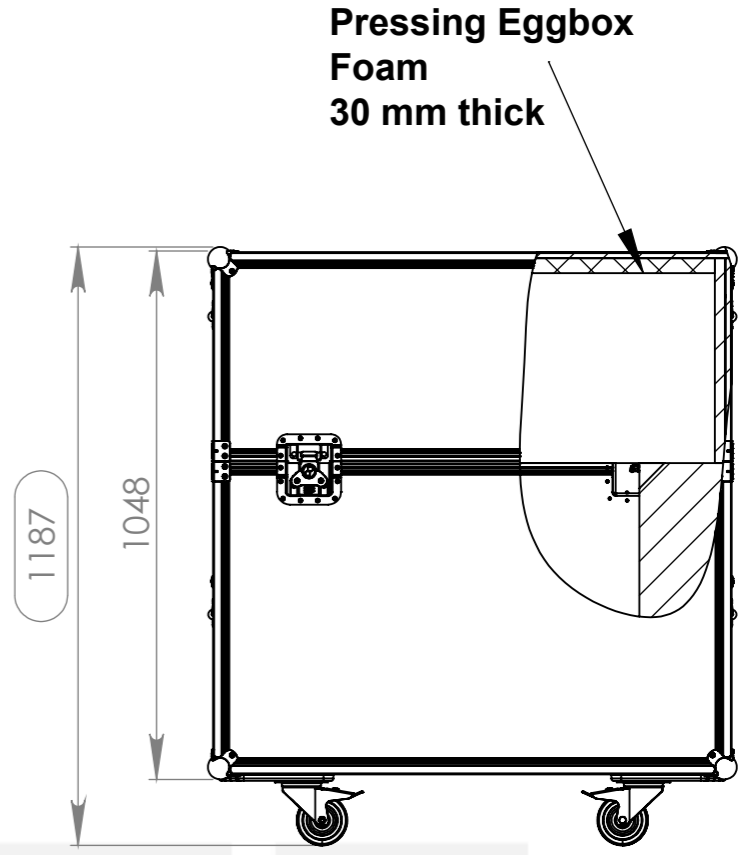
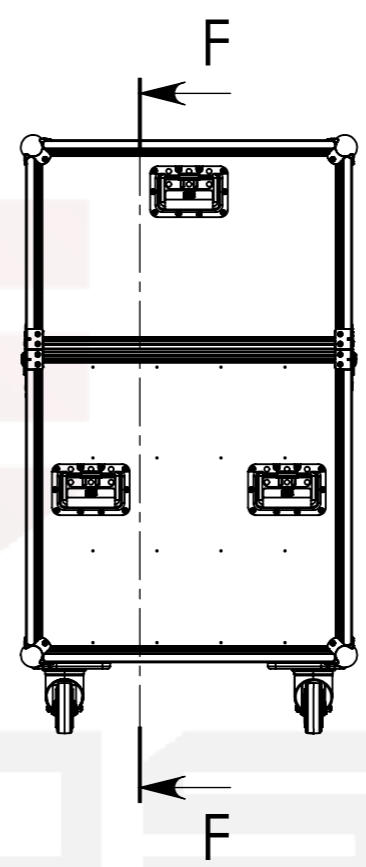
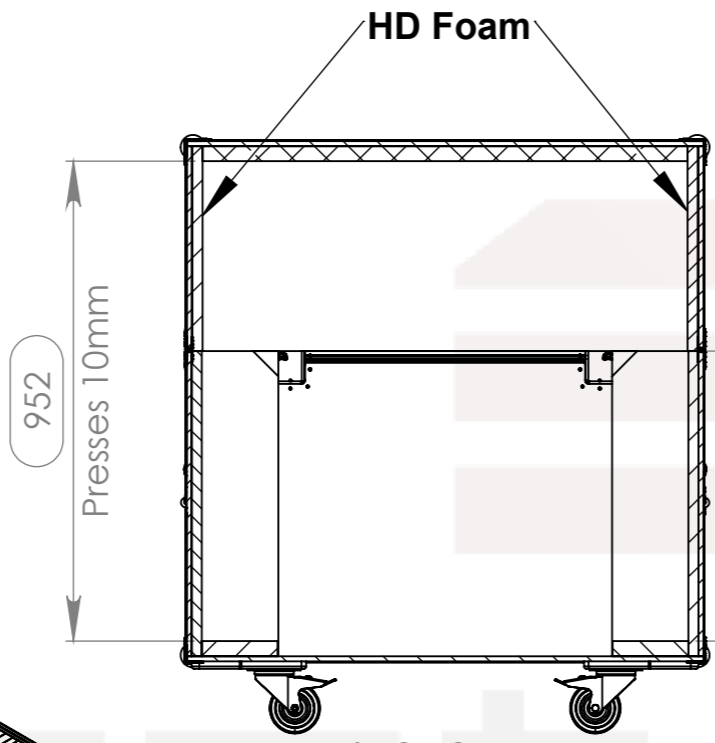
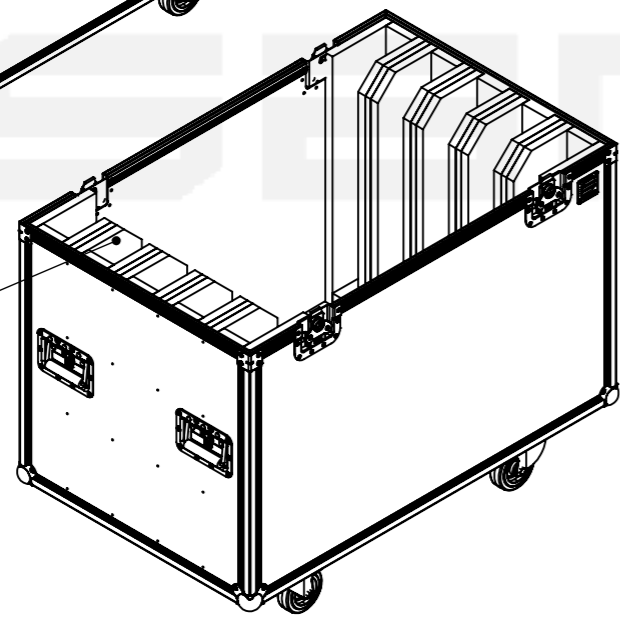
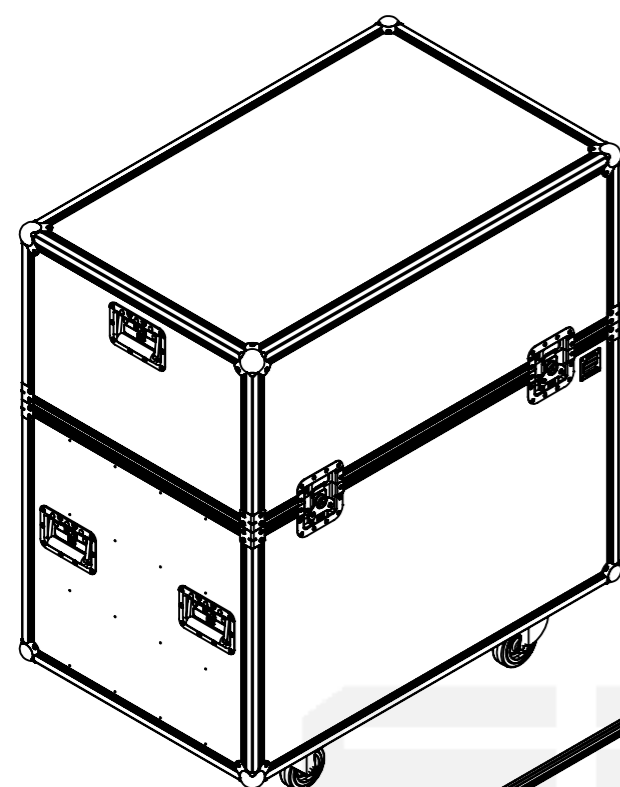

Hardware		
Qty	Ref.	Description
8	4120	Heavy duty ball corner, zinc plated
8	40403	Large corner bracket f. 35mm case angle
6	34082	Recessed sprung handle medium model
2	RODA.100T	Swivel castor Ø100mm with brake
2	RODA.100	Swivel castor Ø100 mm
4	172531	Large butterfly V3 with 'push-back' function

This drawing must not be copied or disclosed without consent of the owner

Drawn by	alexandre	Date	21/12/2016
Reference	PLASB5.0960		
Scale	1:15	units in mm	general tolerance 0.8mm
1st Angle projection	FLIGHTCASE ECO, 5X LED MAX: 960X70X960		

