

Interior dimensions

Width	Depth	Height
77	1154	490
Weight	Approx. 65 Kg	
Wall Thickness	10mm	

REVISIONS				
ZONE	REV.	DESCRIPTION	DATE	APPROVED
-	-	Final Drawing	30-05-2016	Telmo Santos

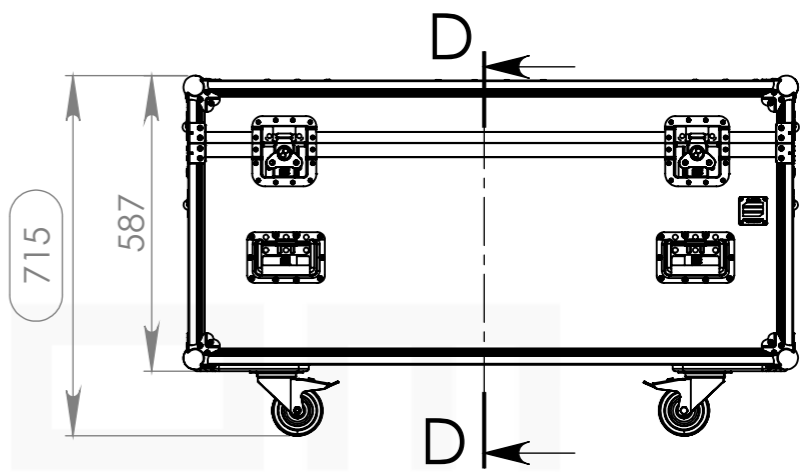
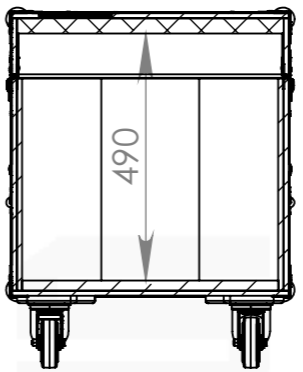
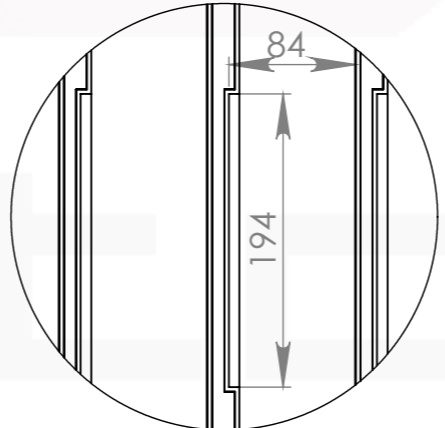
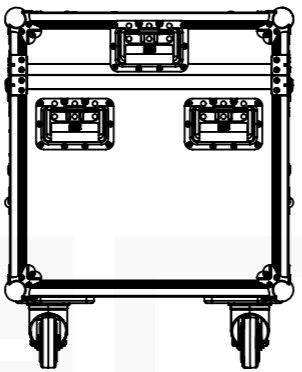
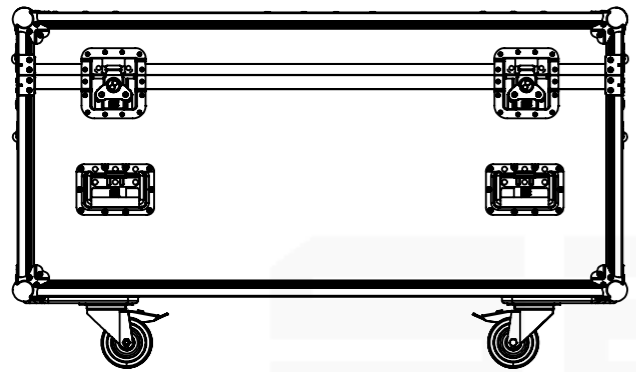
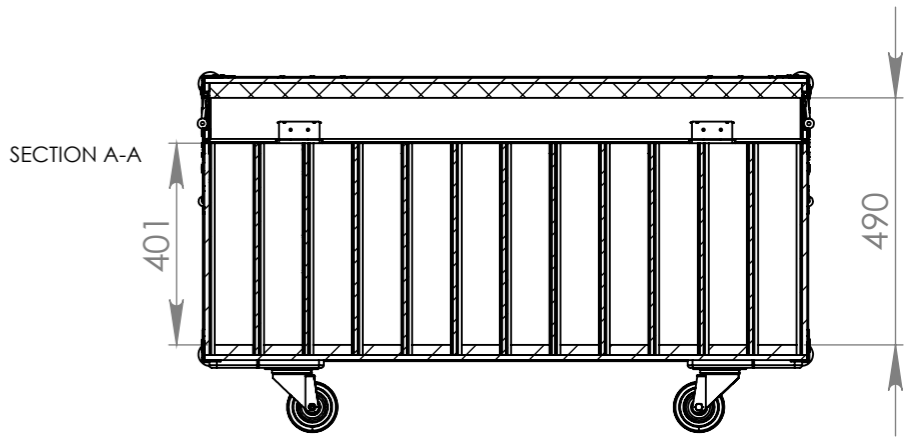
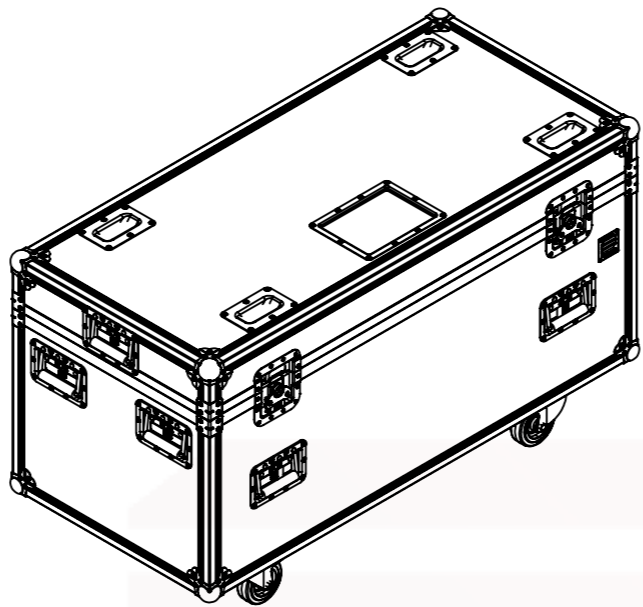

DETAIL E
SCALE 1 : 5

Hardware		
Qty	Ref.	Description
8	410429	Ball Corner large three-leg cranked 35 mm 9 holes
8	40403	Large corner bracket f. 35mm case angle
2	RODA.100T	Swivel castor Ø100mm with brake
2	RODA.100	Swivel castor Ø100 mm
1	88001D	Dish for 88001 Tour Label
4	38083	Castor dish deep zinc plated
10	34082	Recessed sprung handle medium model
4	172531	Large butterfly V3 with 'push-back' function

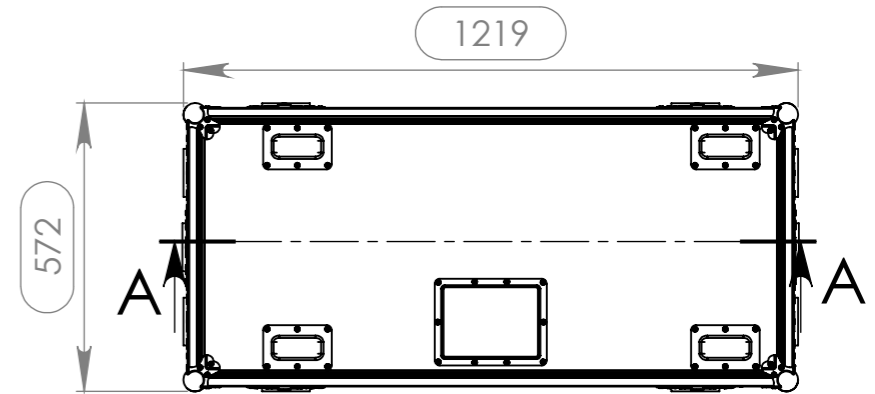
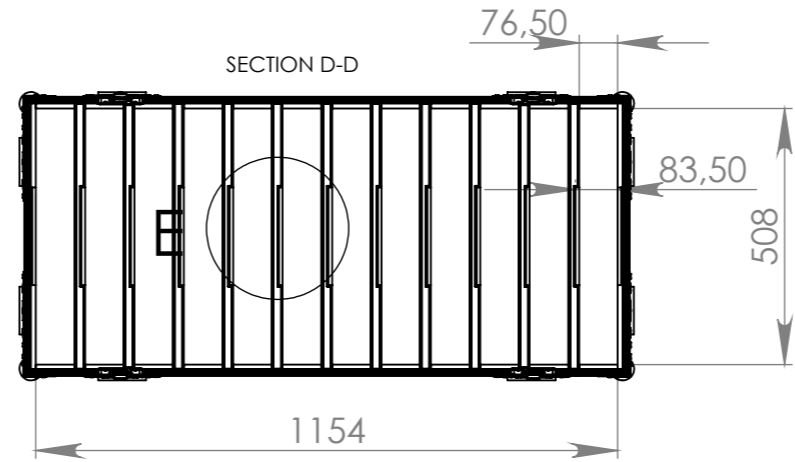

Drawn by	Name	Date
Telmo Santos	Telmo Santos	09/06/2016
Reference	PLASB12.0500	
Scale	units in mm	general tolerance
1:15	DO NOT SCALE	0.8mm
FC, 12X LED DISPLAY+SUPORTE 500X500X75MM, RODAS		



This drawing must not be copied or disclosed without consent of the owner



A3