

Interior dimensions		
Width	Depth	Height
1905	110	1080
Weight	Approx. 86 Kg	
Wall Thickness	10mm	

REVISIONS				
ZONE	REV.	DESCRIPTION	DATE	APPROVED
	0	Final Drawing	30/07/2016	Carlos Rodrigues

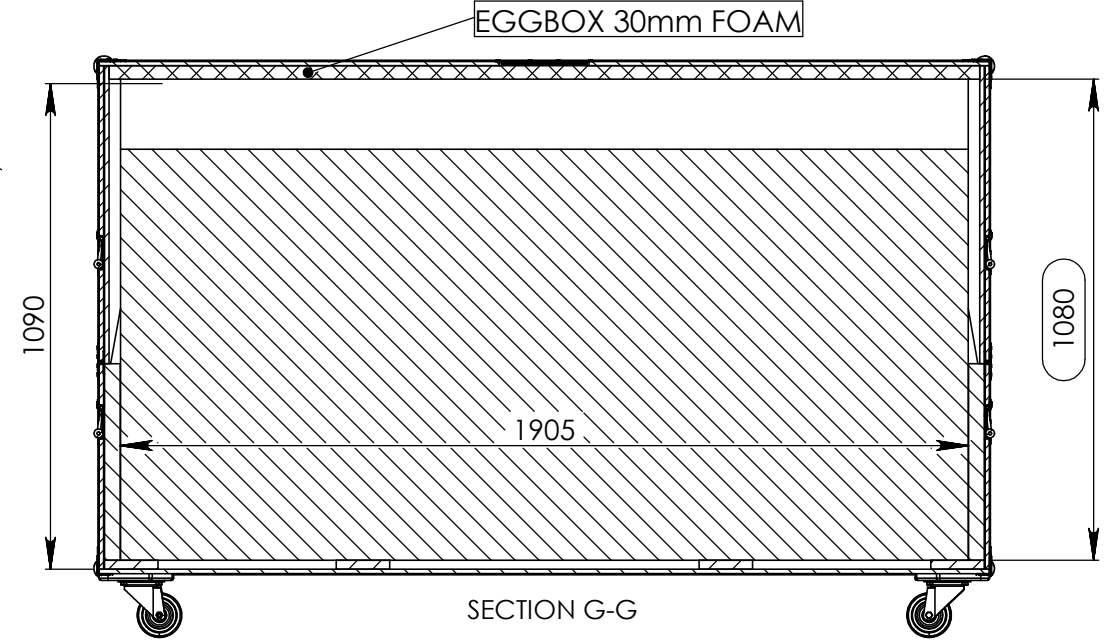

BASE TOP VIEW

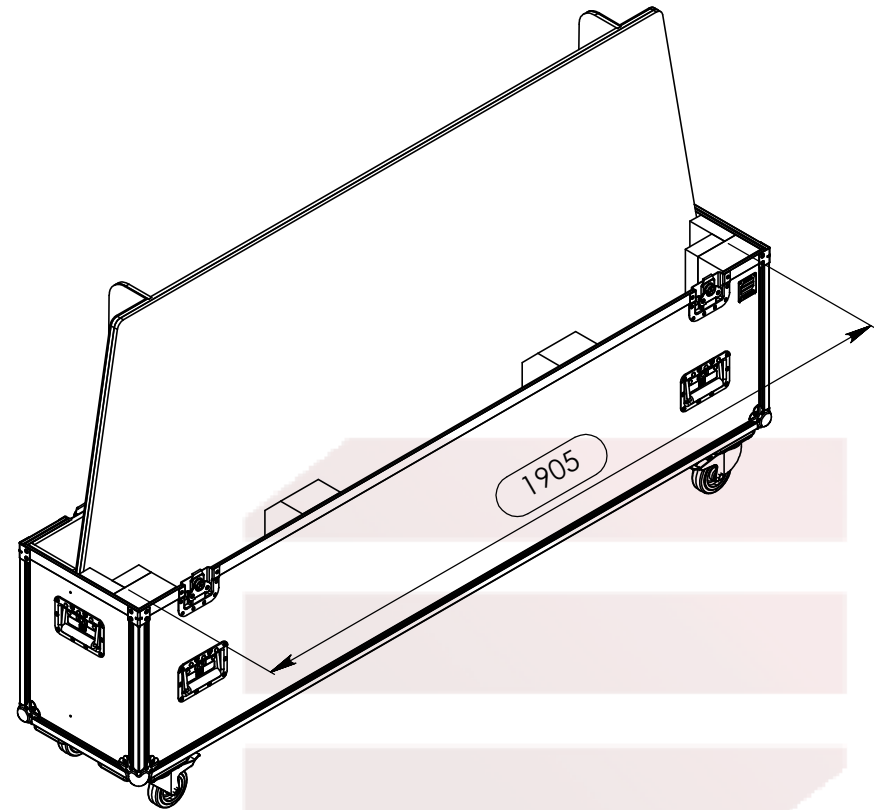
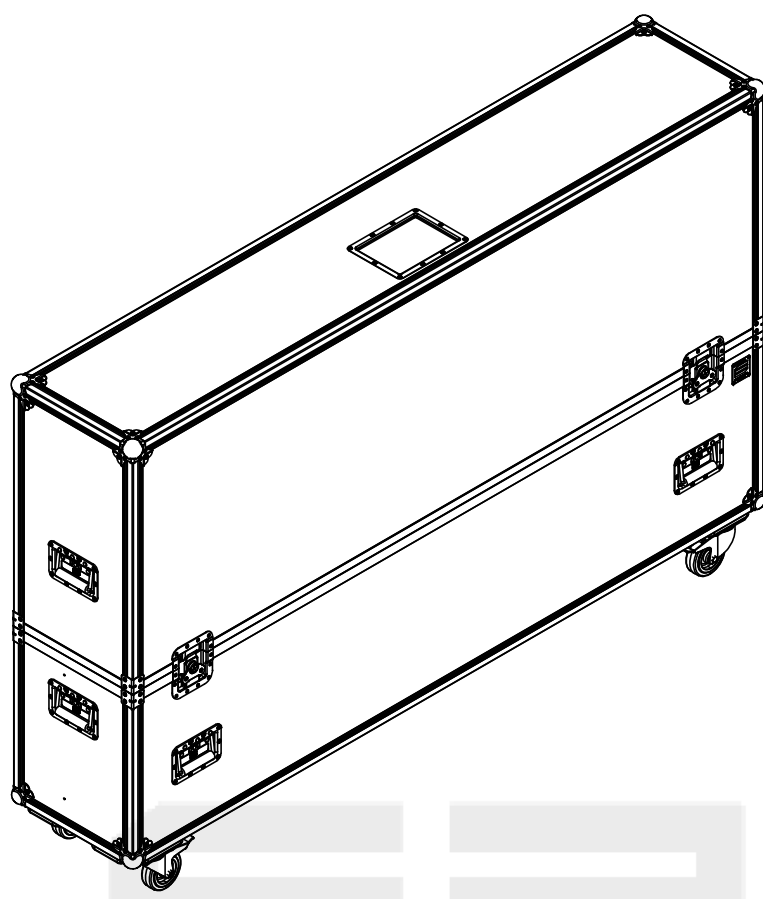
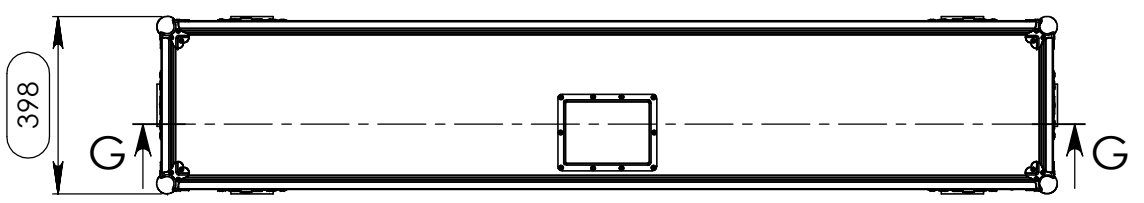
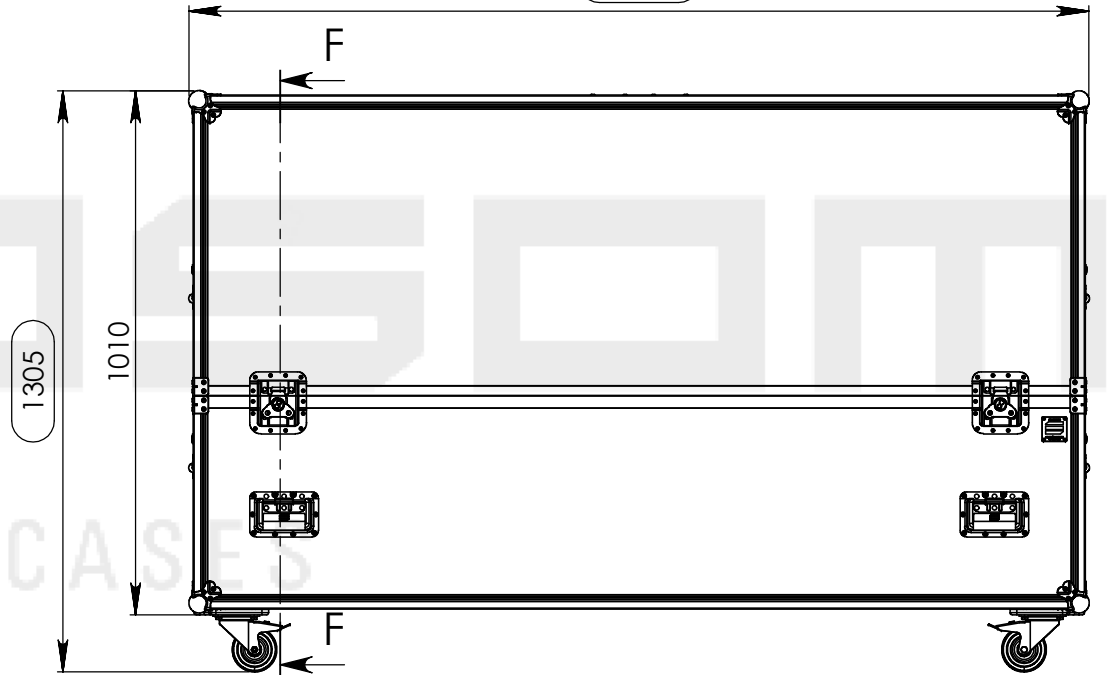
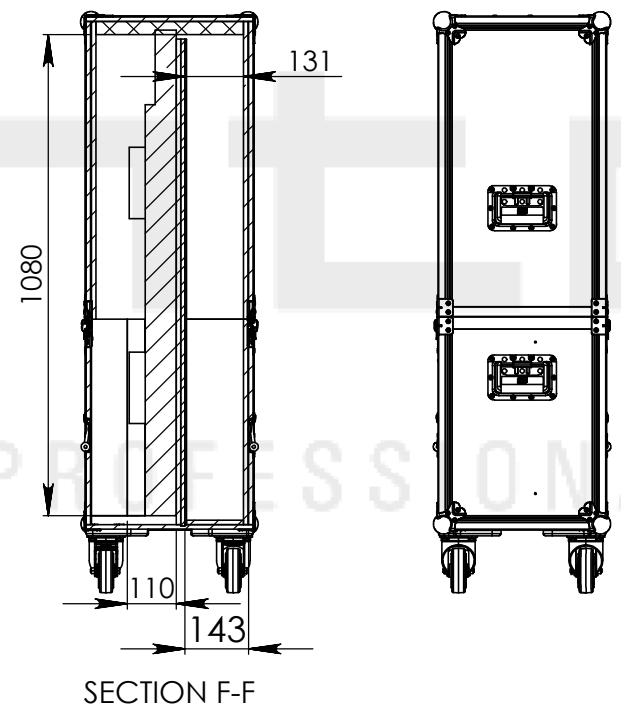
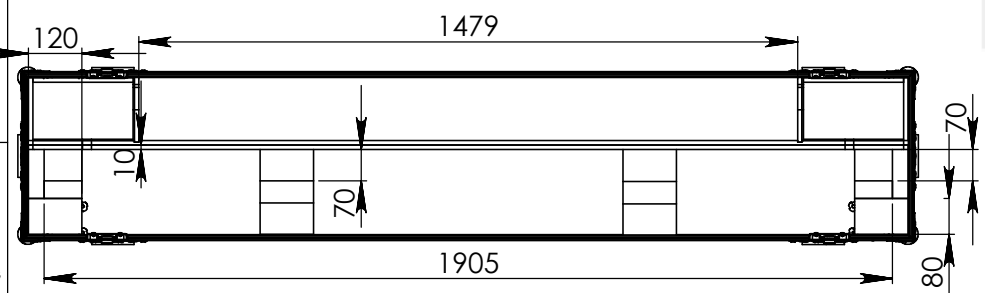

Hardware		
Qty	Ref.	Description
8	410429	Heavy Duty Ball Corner
8	40403	Large corner bracket f. 35mm case angle
4	172531	Large butterfly V3 with 'push-back' function
8	34082	Recessed sprung handle medium model
1	88001D	Dish for 88001 Tour Label
1	CHAPA.1000	Identification Plate
2	RODA.100T	Swivel castor Ø100mm with brake

Drawn by	projects	Date	01/08/2016
Reference	PLASB1.084		
Scale	1:12	general tolerance	±0.8mm
1st Angle projection			

This drawing must not be copied or disclosed without consent of the owner

FLIGHTCASE, LCD MAX: 1950X125X1200

14-111201-WP-125116