

Equipment	LCD 65"	
Width (MAX.)	Depth (MAX.)	Height (MAX.)
1560	115	915
Internal Dimensions		
Width	Depth	Height
1296	230	770
Weight	Approx. 39 Kg	
Wall Thickness	10mm	

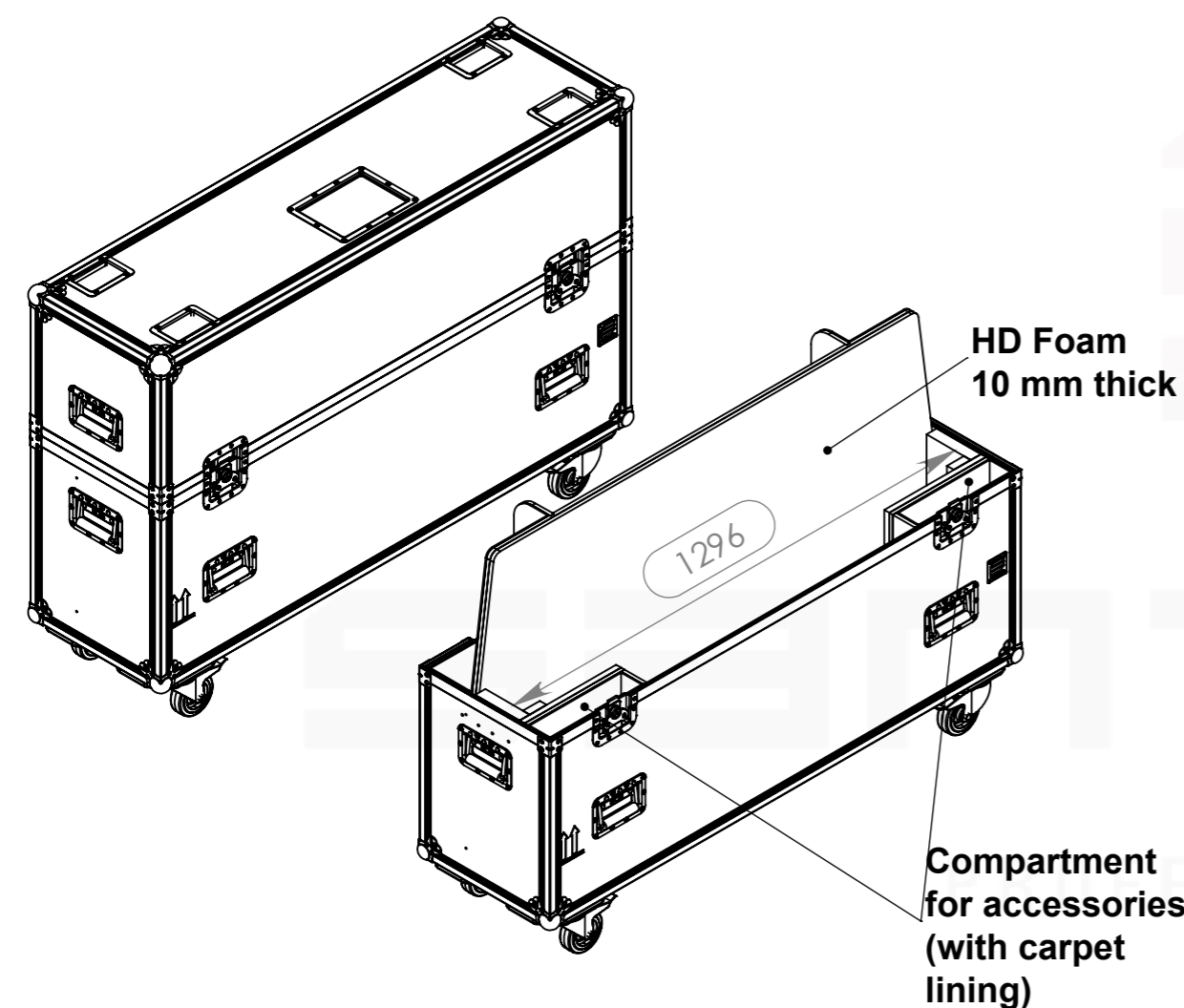

Pressing Eggbox Foam
30 mm thick

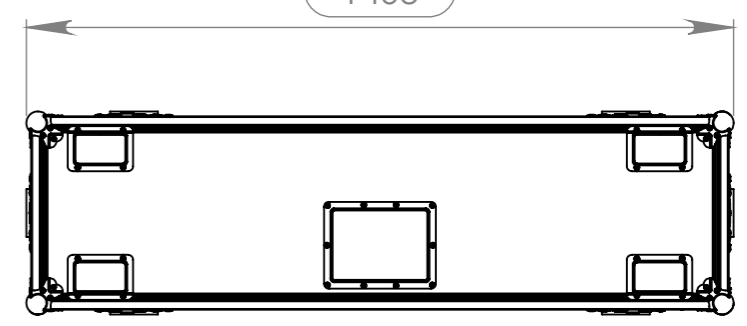
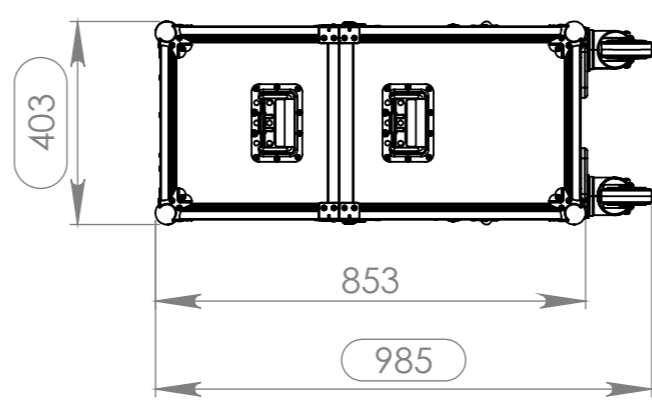
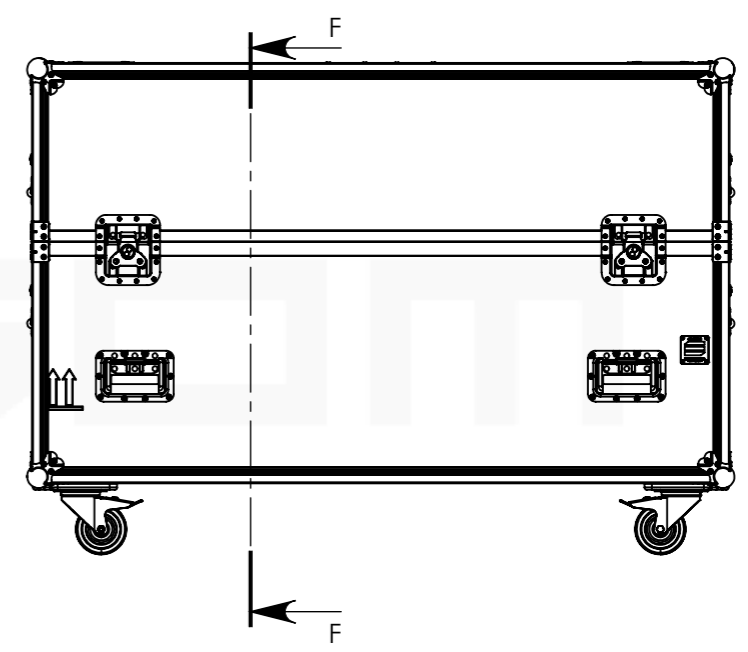
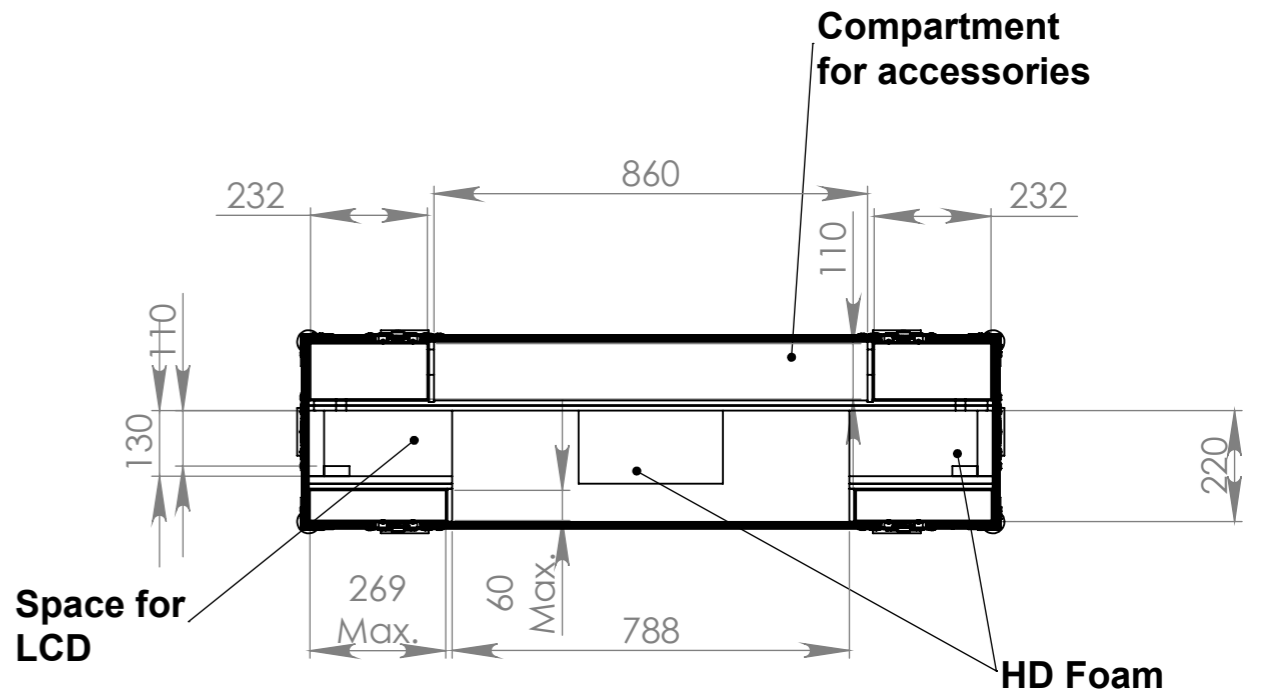
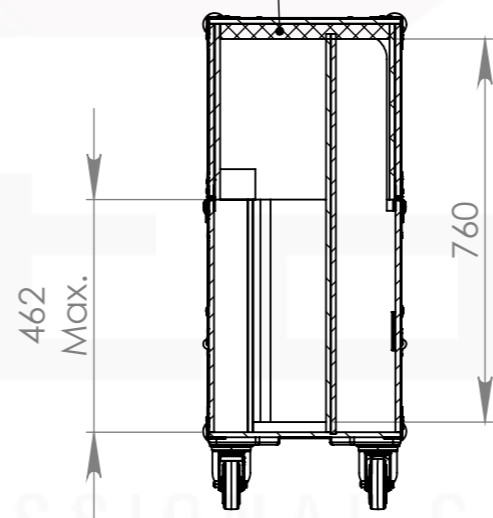

Hardware		
Qty	Ref.	Description
8	410429	Ball Corner large three-leg cranked 35 mm 9 holes
8	40403	Large corner bracket f. 35mm case angle
4	172531	Large butterfly V3 with 'push-back' function
8	34082	Recessed sprung handle medium model
1	88001D	Dish for 88001 Tour Label
1	CHAPA.1000	Identification Plate
2	RODA.100T	Swivel castor Ø100mm with brake
2	RODA.100	Swivel castor Ø100 mm
4	38082	Castor dish deep zinc plated

This drawing must not be copied or disclosed without consent of the owner

Drawn by	Name	Date
projects		21/02/2017
Reference	PLASB1.055	
Scale	units in mm	general tolerance
1:15	DO NOT SCALE	0.8mm
FLIGHTCASE, LCD MAX: 1290X150X770		

