

Interior dimensions		
Width	Depth	Height
1047	2605	2605
Weight	Approx. 128 Kg	
Wall Thickness		10mm

REVISIONS				
ZONE	REV.	DESCRIPTION	DATE	APPROVED
-	-	Final Drawing	10/01/2014	Pedro Neves

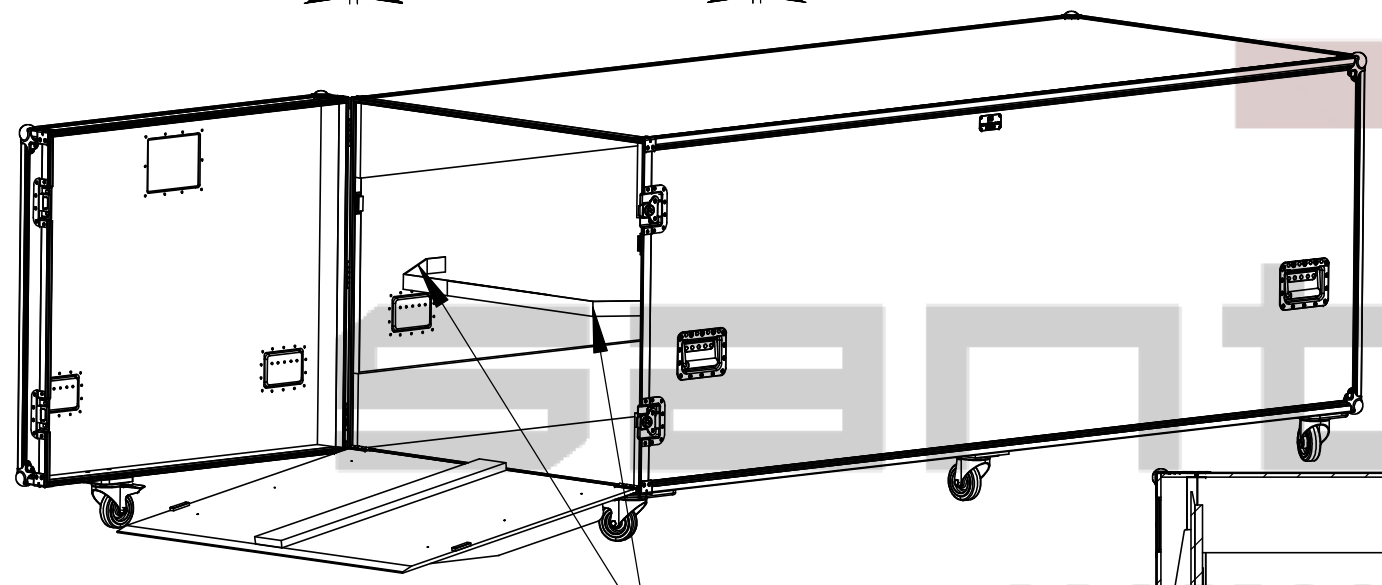

Fita para amarrar o equipamento

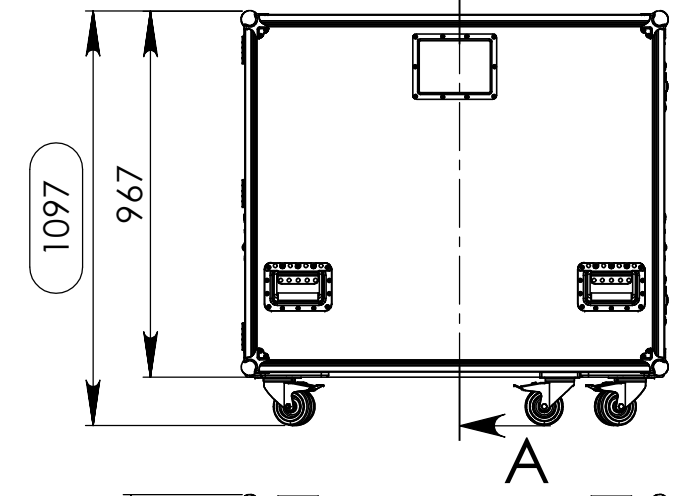
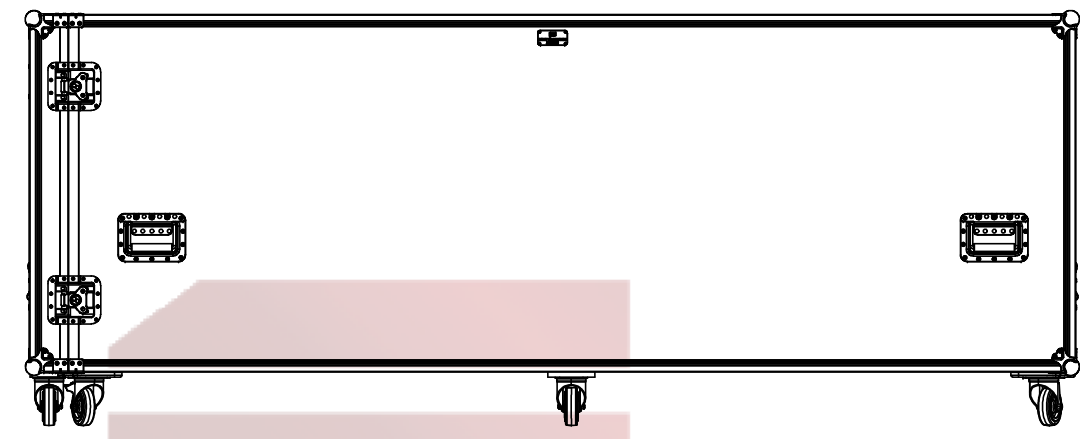
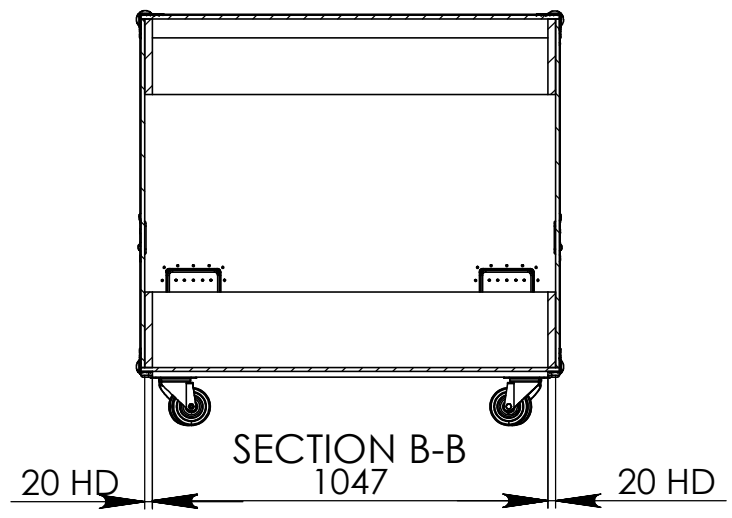
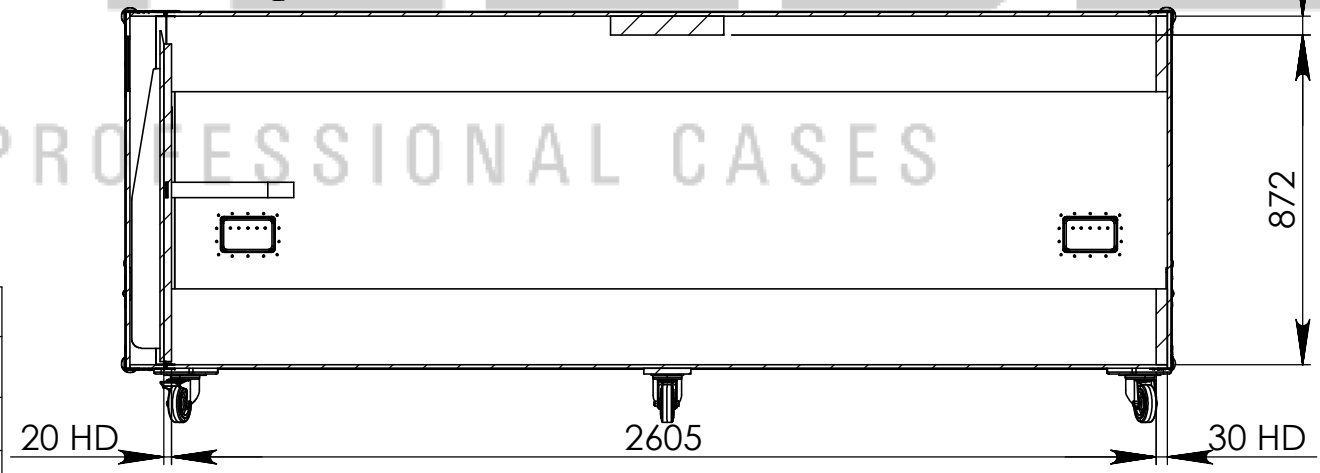

SECTION A-A

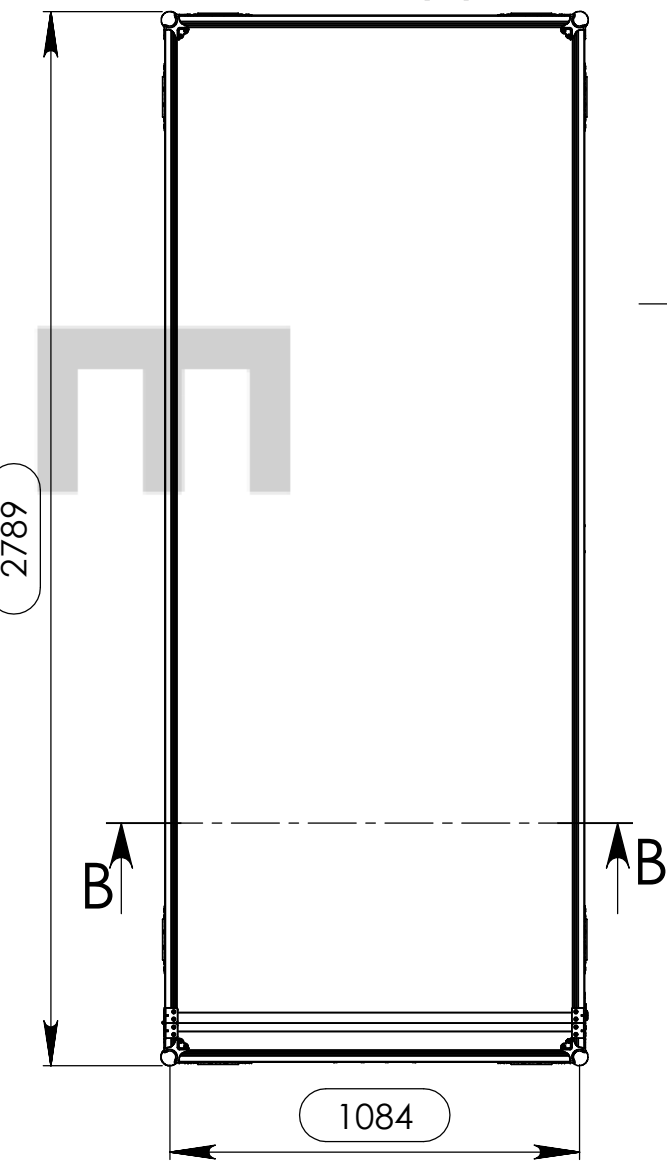

Hardware		
Qty	Ref.	Description
8	410429	Heavy Duty Ball Corner
8	40403	Large corner bracket f. 35mm case angle
2	172531	Large butterfly V3 with 'push-back' function
4	RODAS.1001	Castor plate wood black
3	RODA.100T	Swivel castor Ø100mm with brake
4	RODA.100	Swivel castor Ø100 mm
8	34085	Large, heavy duty, recessed sprung handle
5	2602	Medium duty butt hinge z./p.
1	88001D	Dish for 88001 Tour Label

This drawing must not be copied or disclosed without consent of the owner

Name	Date
pedroneves	10-01-2014
Reference	ORCH.109
Scale	1:20
units in mm	general tolerance
DO NOT SCALE	±0.3mm
FC. MARIMBA YAMAHA YMS100A, C/ RAMPA, RODAS	



REVISIONS				
ZONE	REV.	DESCRIPTION	DATE	APPROVED
-	-	See Desenho de Artigo	-	-

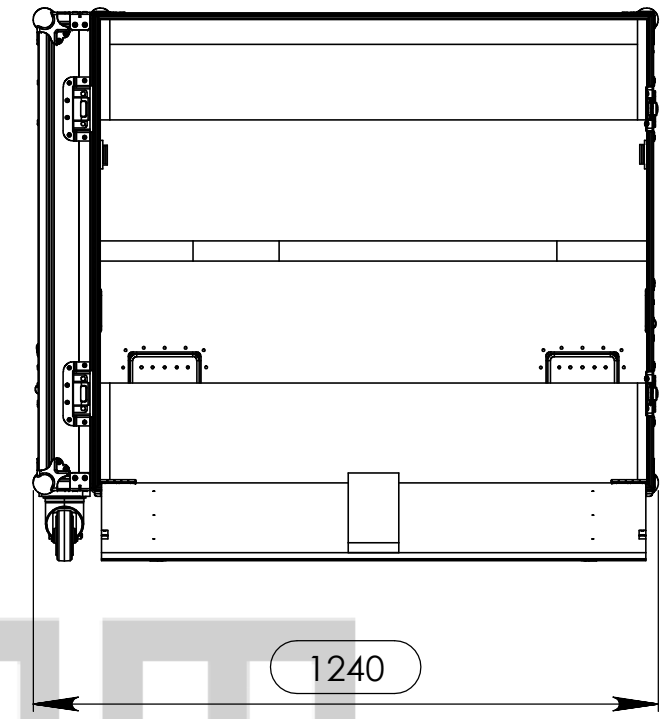
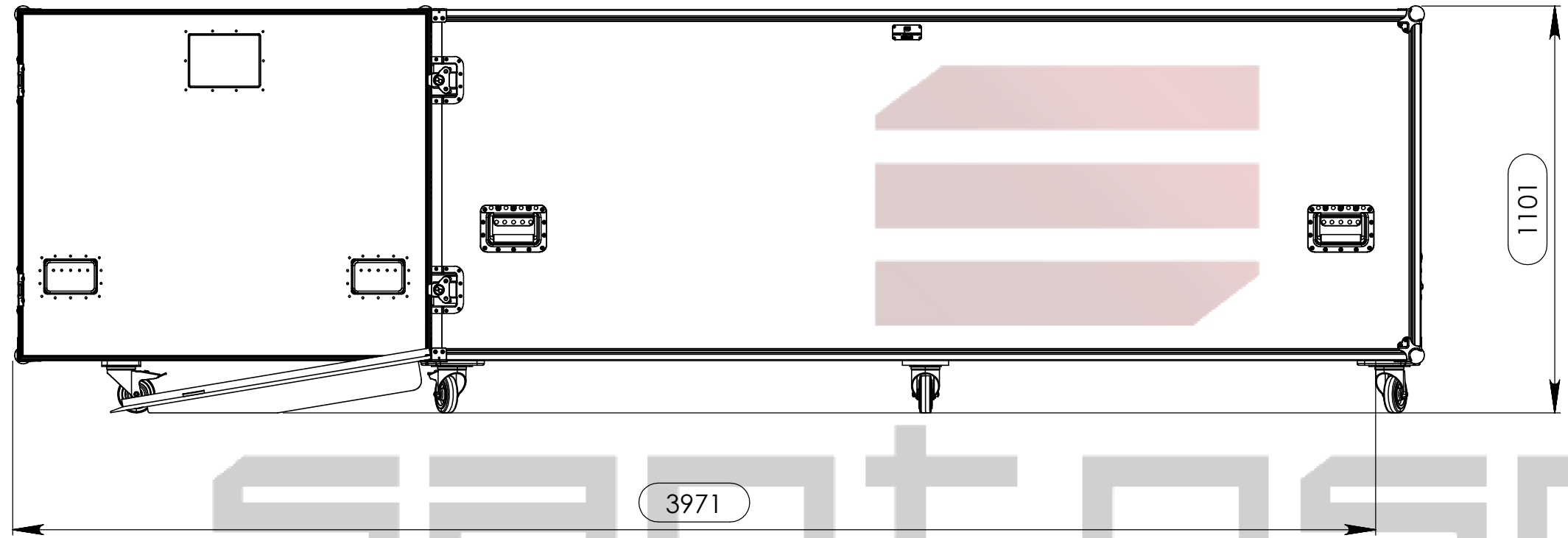

santosom  
PROFESSIONAL CASES

Drawn by	pedroneves	Date	10-01-2014
Reference	ORCH.109		
Scale	1:15	units in mm	general tolerance 0.8mm
1st Angle projection		FC. MARIMBA YAMAHA YG2500, C/ RAMPA, RODAS	

This drawing must not be copied or disclosed without consent of the owner

