

Interior dimensions

Width	Depth	Height
910	1005	862
Weight	Approx. 58 Kg	
Wall Thickness	10mm	

REVISIONS

ZONE	REV.	DESCRIPTION	DATE	APPROVED
-	-	Final Drawing	30/06/2015	Carlos Rodrigues

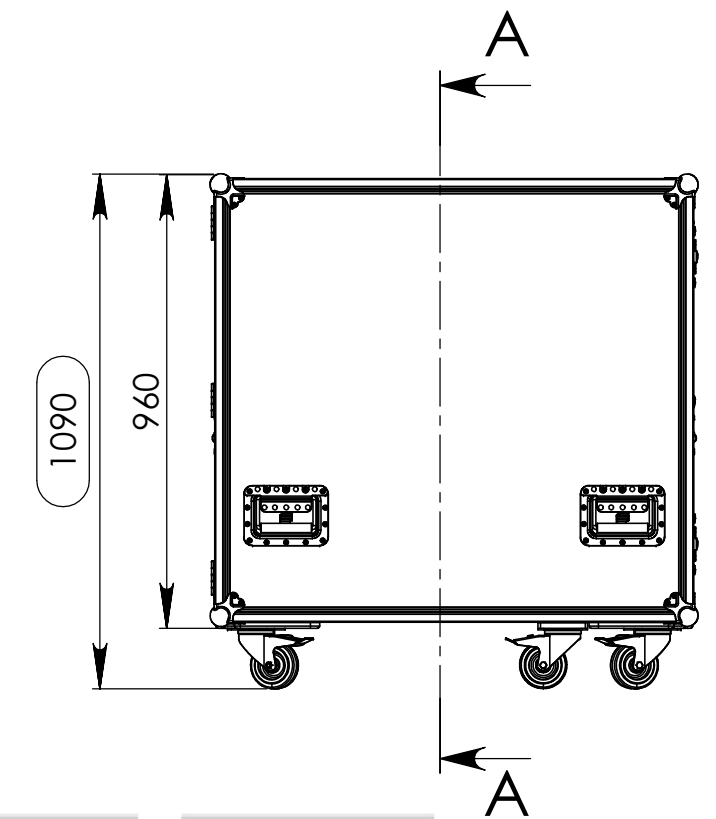
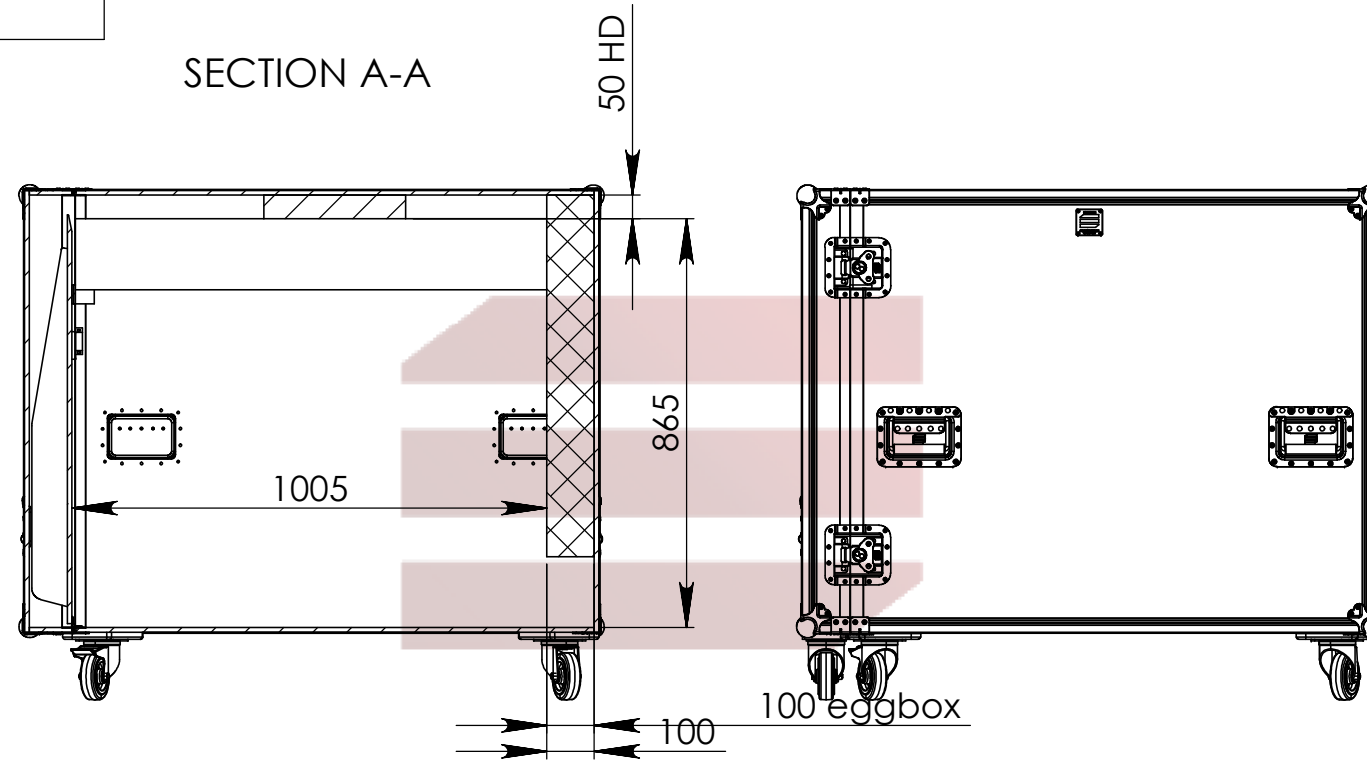
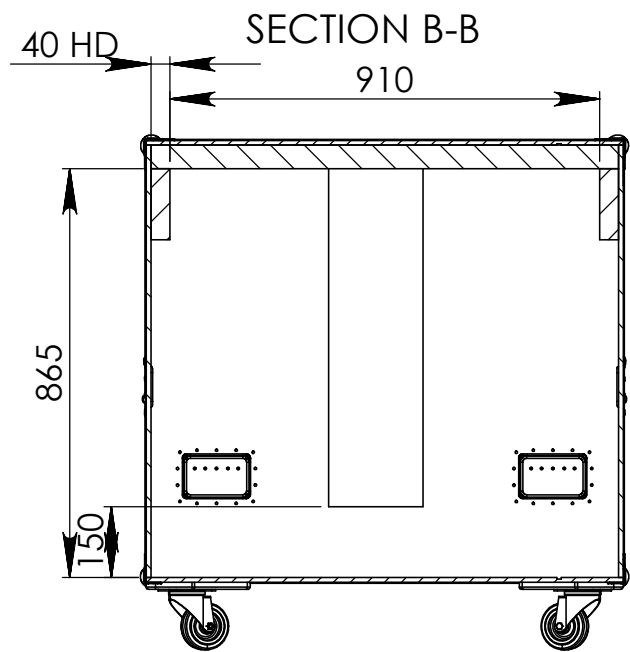

santosom

velcro para segurar equipamento

PROFESSIONAL CASES

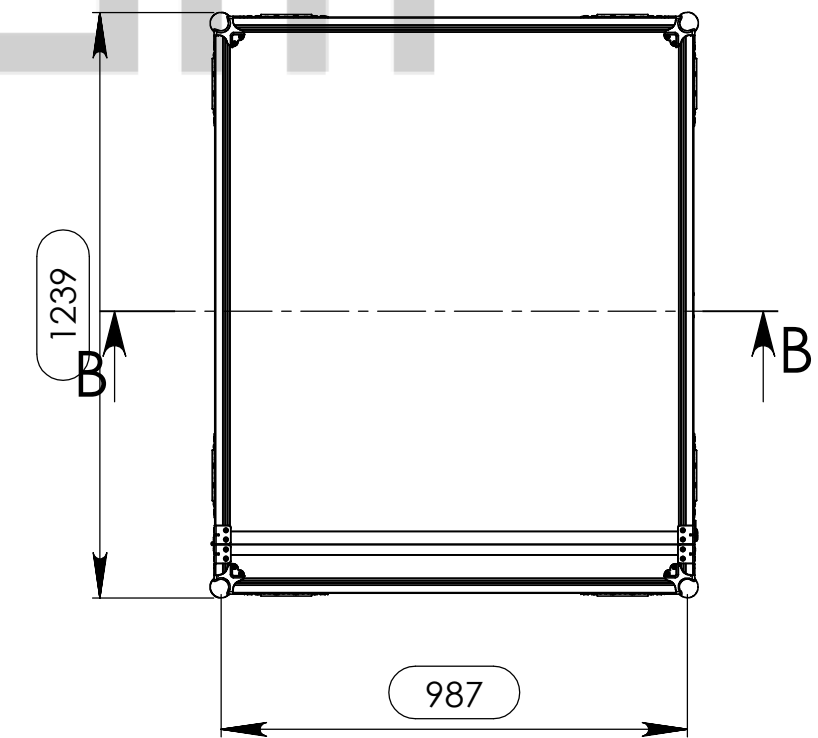
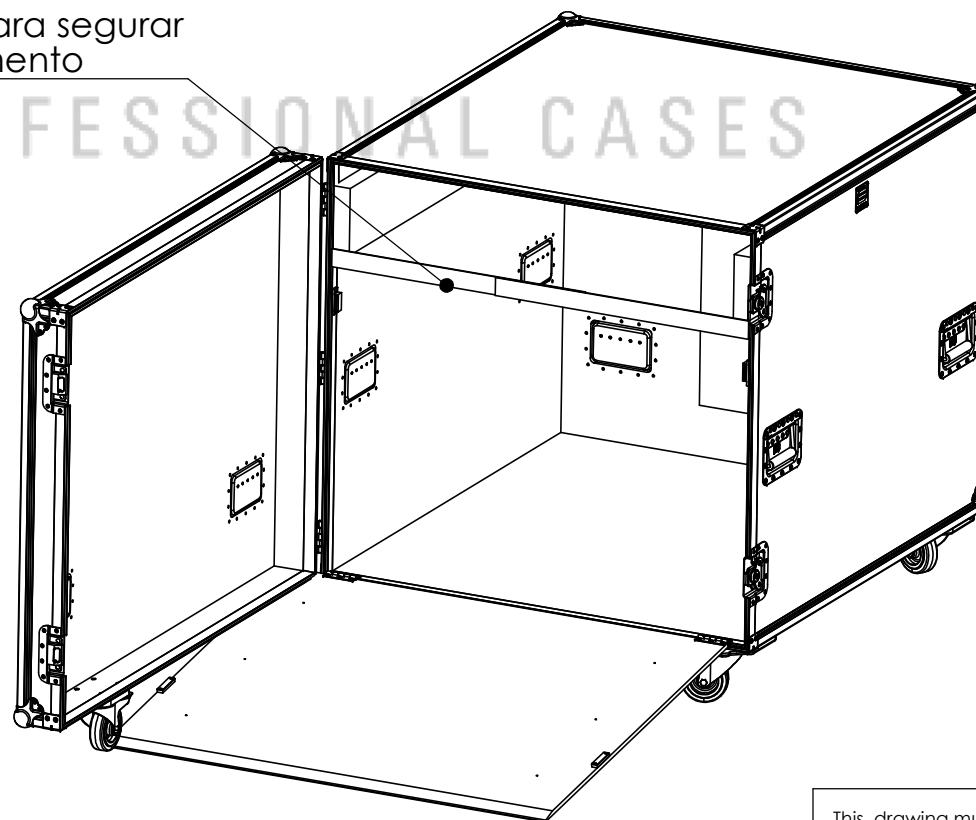

Hardware		
Qty	Ref.	Description
8	410429	Heavy Duty Ball Corner
8	40403	Large corner bracket f. 35mm case angle
2	172531	Large butterfly V3 with 'push-back' function
4	RODAS.1001	Castor plate wood black
3	RODA.100T	Swivel castor Ø100mm with brake
2	RODA.100	Swivel castor Ø100 mm
8	34085	Large, heavy duty, recessed sprung handle
5	2602	Medium duty butt hinge z./p.

This drawing must not be copied or disclosed without consent of the owner

Drawn by	Name	Date
projects		06/08/2015
Reference	ORCH.104A	
Scale	units in mm	general tolerance
1:16	DO NOT SCALE	0.8mm
FC, TIMPANO SINFONICO 32" ADAMS C/ RAMPA, RODAS		

