

Equipment		Module 96x Spigot	
Width	Depth	Height	
Ø17	Ø17	92	
Weight	Approx. Kg		
Internal Dimensions			
Width	Depth	Height	
135	205	95	
Weight	Approx. 3.26 Kg		
Wall Thickness		mm	

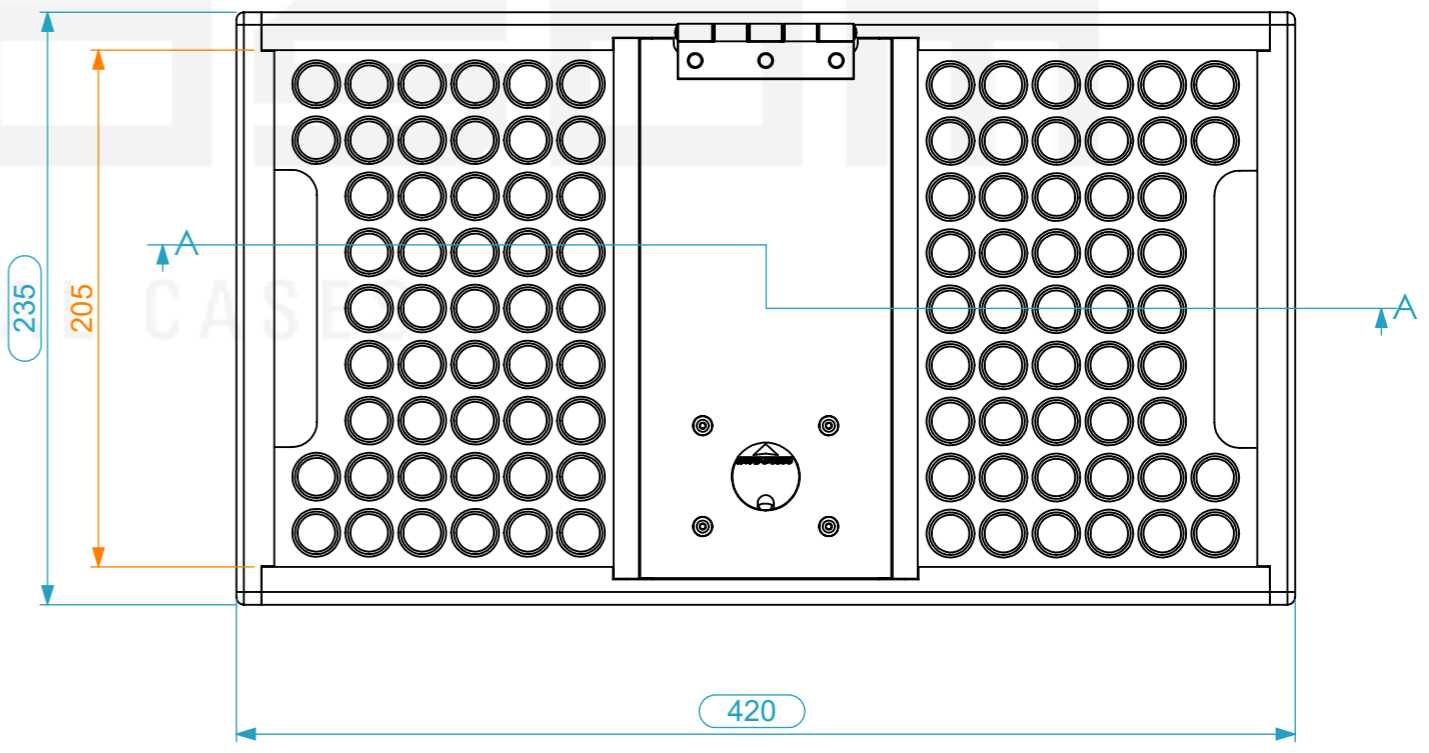

Drawn by	Name	Date
paula.almeida		08/01/2026
Reference	MTC9810	
Scale	units in mm	general tolerance
1:3	DO NOT SCALE	0.8mm
Modulo 98 pinos Ø17x92 + 100 R-Spring		

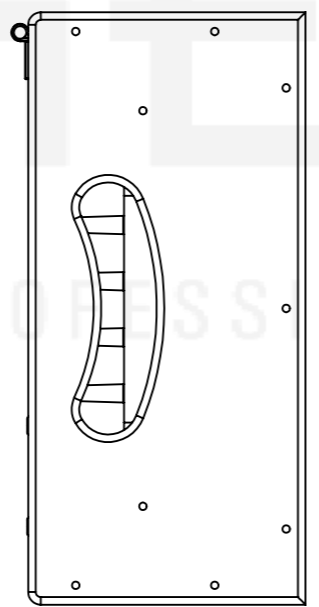
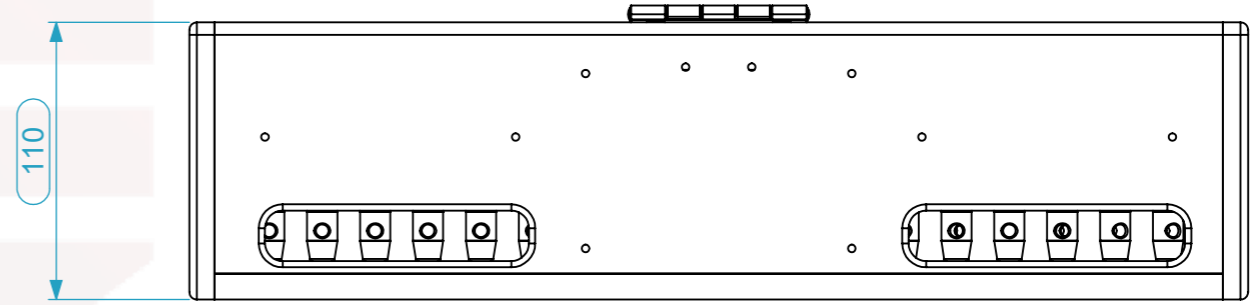
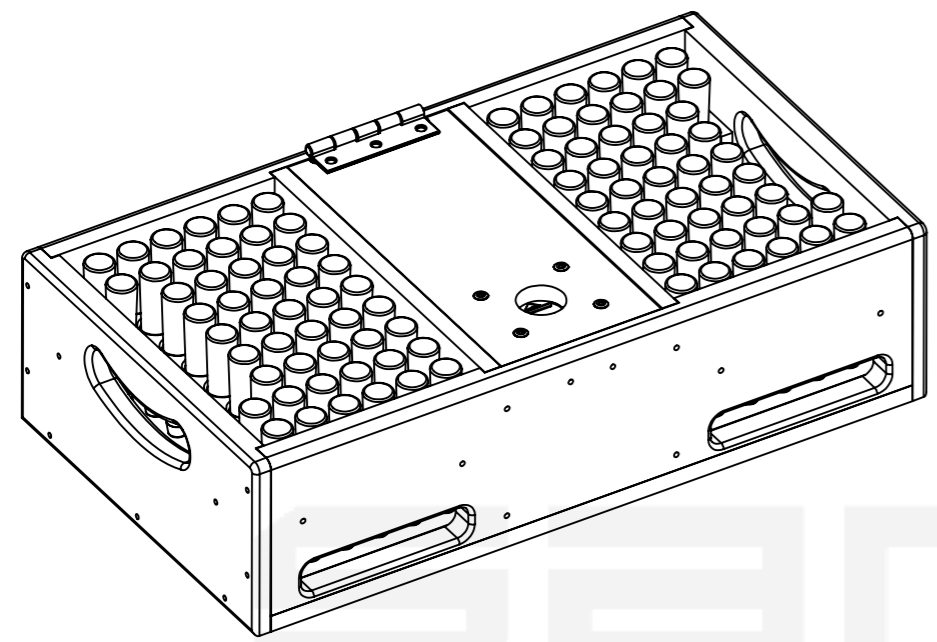
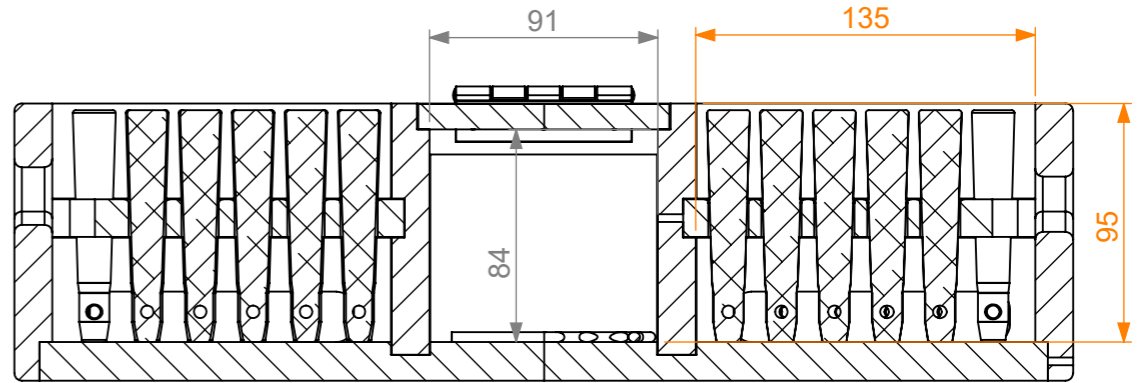

This drawing must not be copied or disclosed without consent of the owner



A3