

Equipment			NEXO P15		
Width	Depth	Height			
483	352	600			
Weight	Approx. 23 Kg				
Internal Dimensions					
Width	Depth	Height			
689	487	600			
Weight	Approx. 35 Kg				
Wall Thickness		10mm			

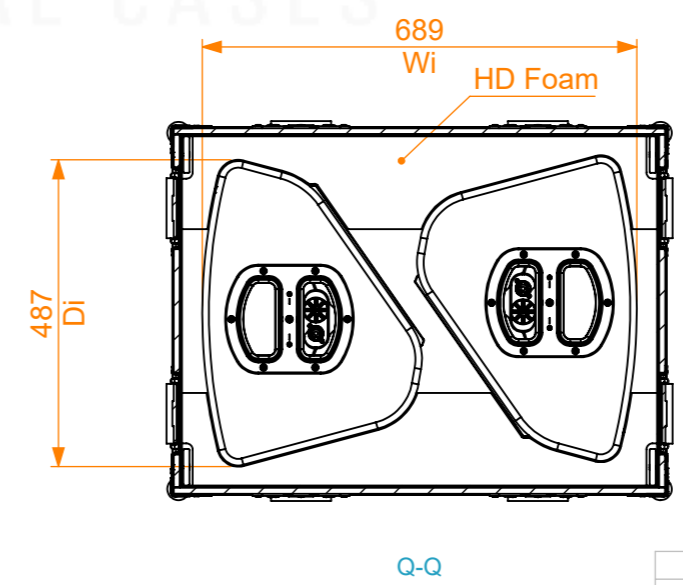

General External Dimensions	
W	Width
D	Depth
H	Height
Usable Inner Dimensions	
Wi	Inside Width
Di	Inside Depth
Hi	Inside Height

Name	projects	
Date	05/05/2022	
Reference	MONITOR.725	
Scale	1:12	units in mm
DO NOT SCALE		general tolerance 0.8mm
Flight case PRO. 2x NEXO P15		

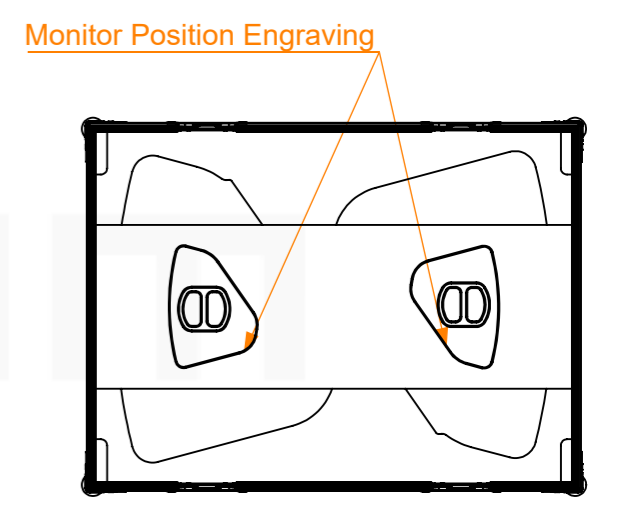
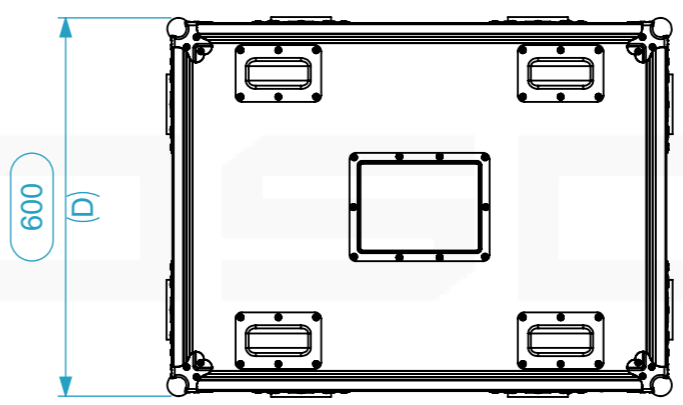
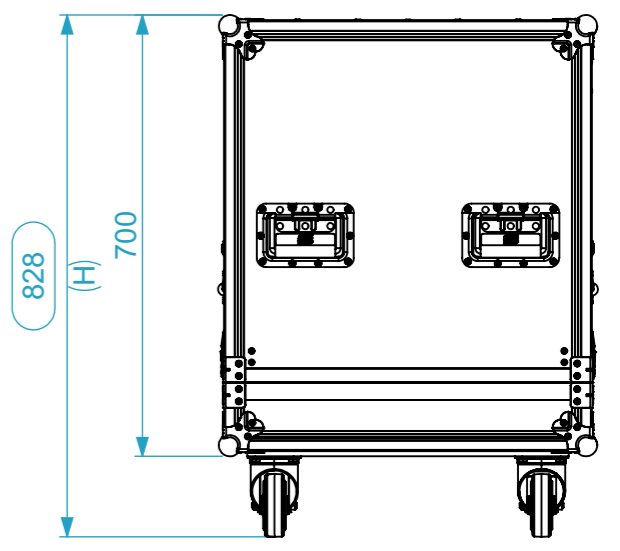
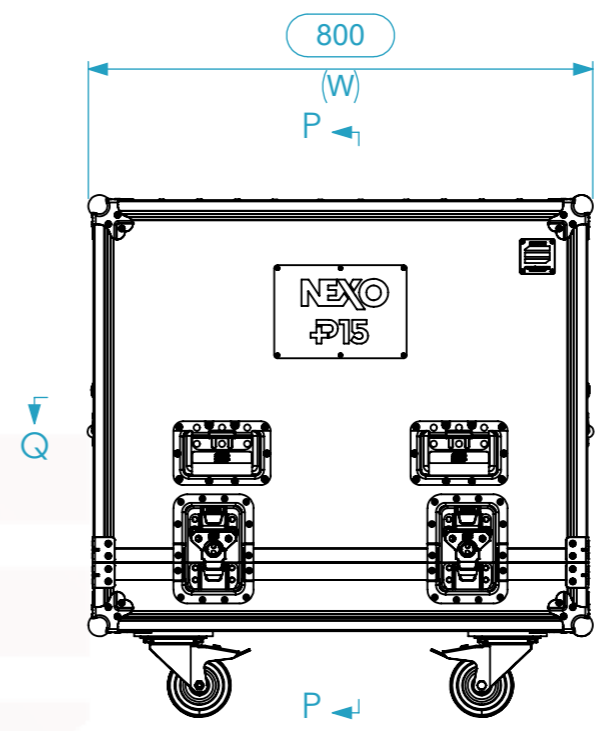
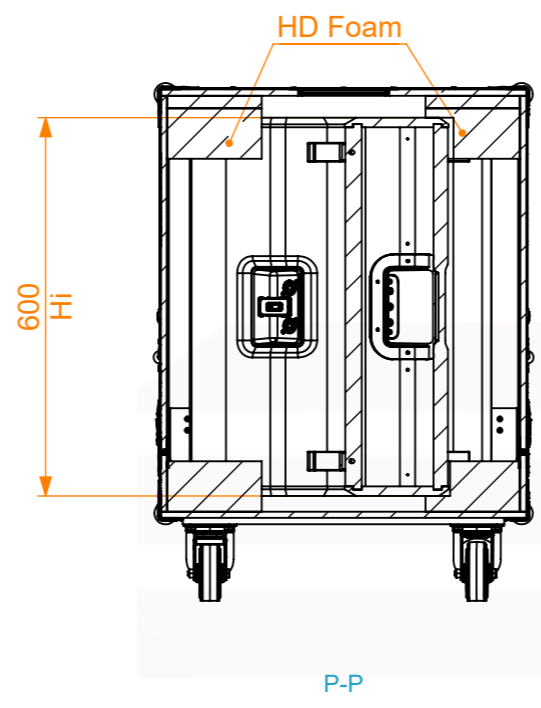
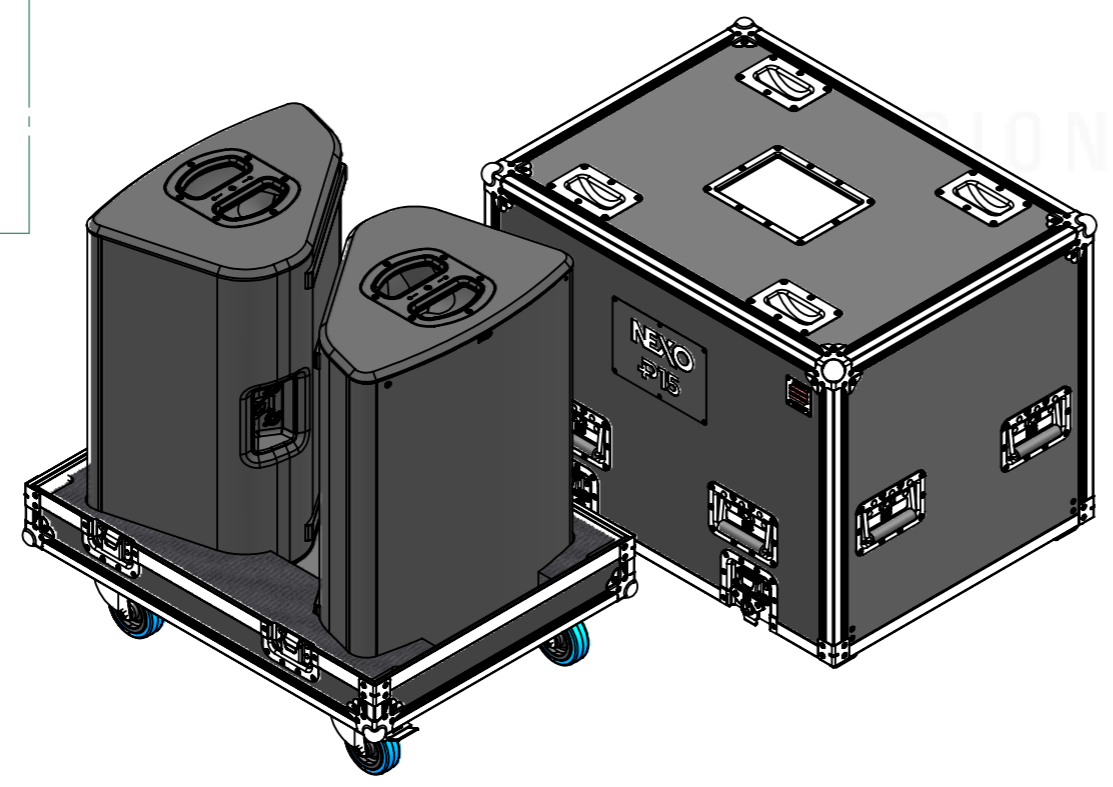
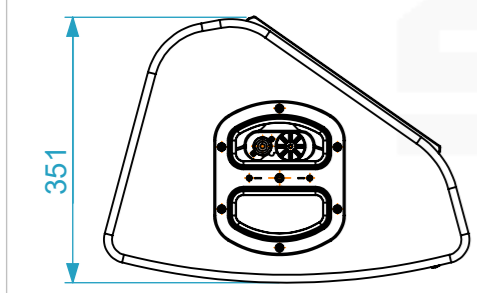
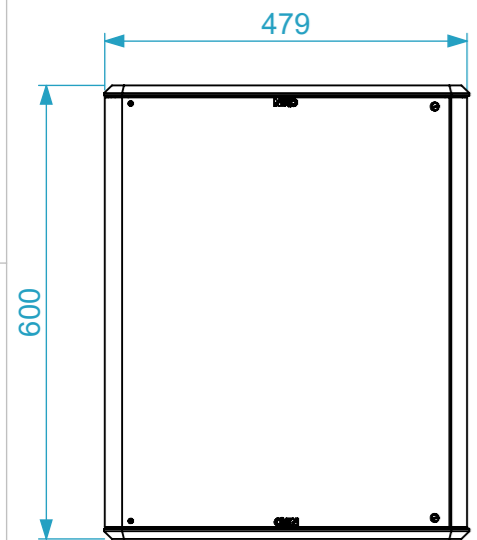

This drawing must not be copied or disclosed without consent of the owner



A3