

Internal Dimensions		
Width	Depth	Height
590	540	600
Weight	Approx. 29 Kg	
Wall Thickness		10mm

PRO MON P15/A15

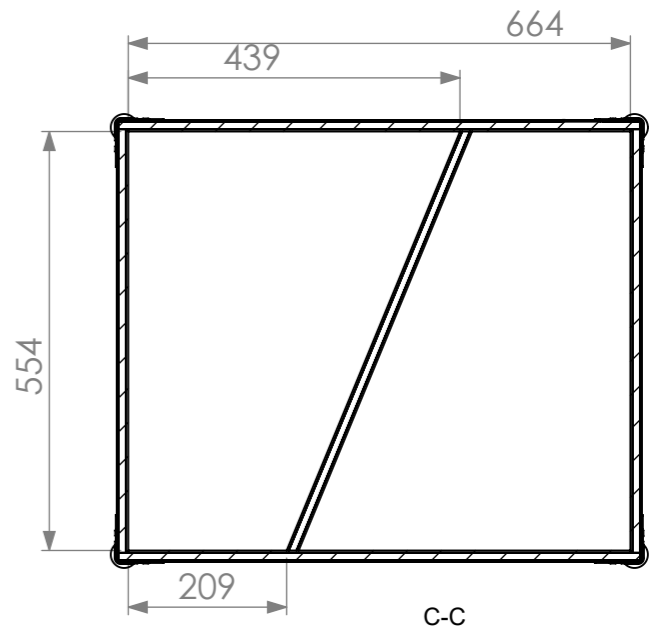
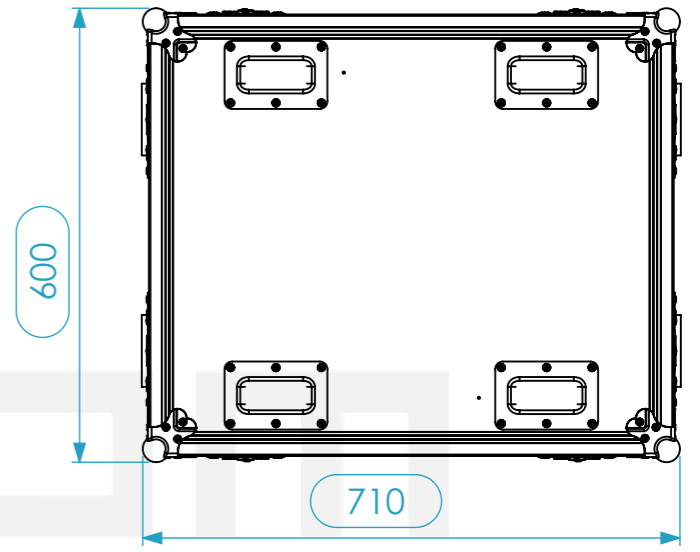
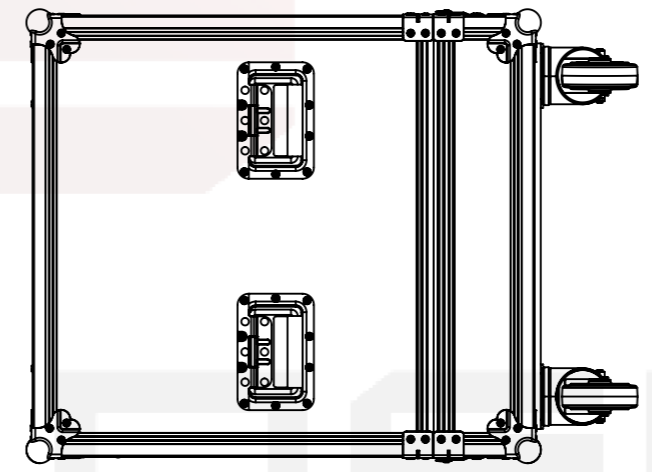
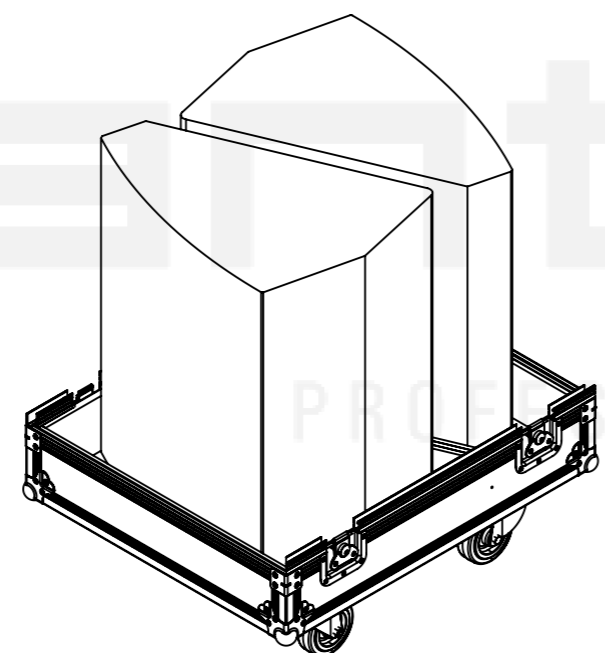
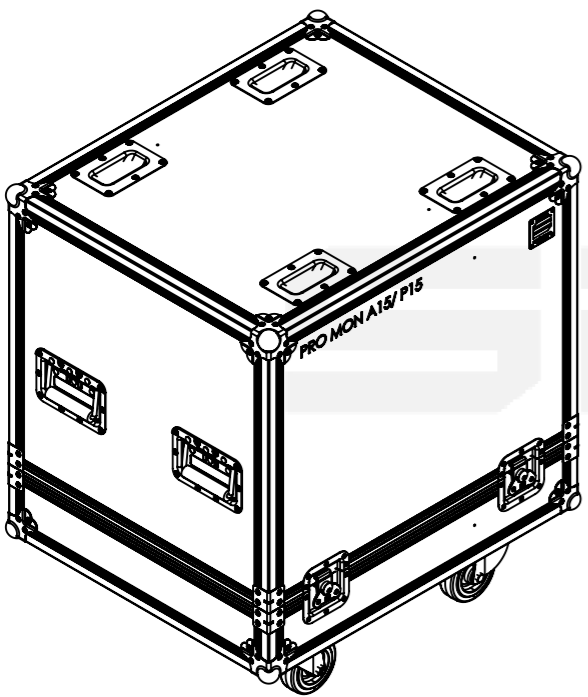
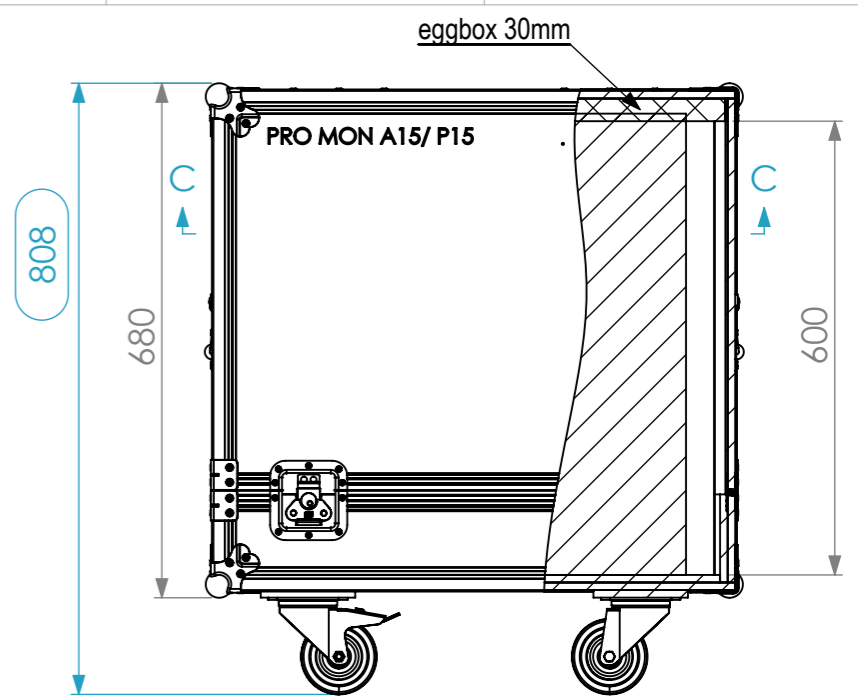
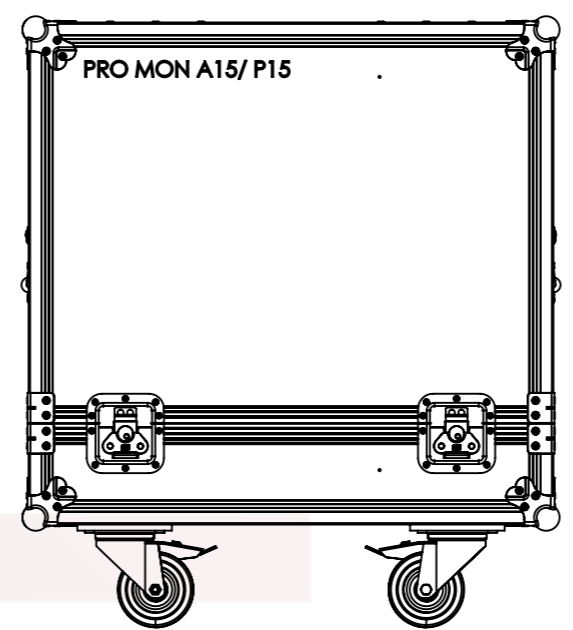
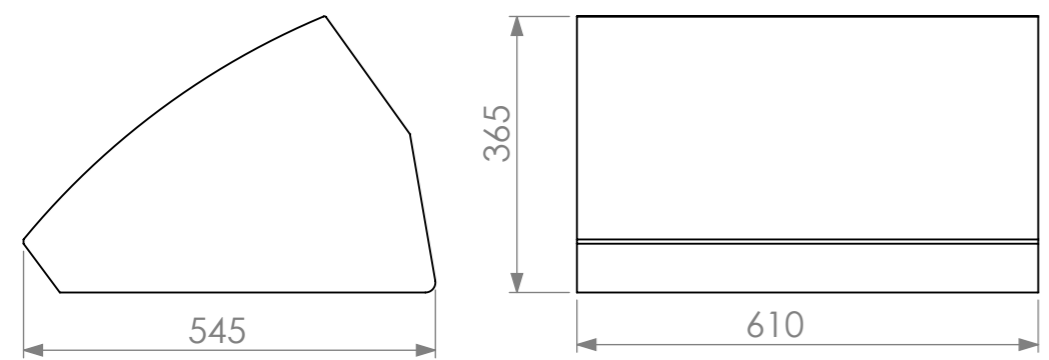

Hardware		
Qty	Ref.	Description
8	40403	Large corner bracket f. 35mm case angle
4	34082	Recessed Sprung Handle Medium
2	RODA.100T	Swivel castor Ø100mm with brake
2	RODA.100	Swivel castor Ø100 mm
8	410429	Heavy Duty Ball Corner
4	17290S	Key lockable medium Butterfly special
4	38083	Castor dish deep zinc plated
2	R1.060	Whells Feet for 600mm cases

This drawing must not be copied or disclosed without consent of the owner

Drawn by	Name	Date
CarlaSilva	CarlaSilva	05/01/2018
Reference	MONITOR.709R	
Scale	units in mm	general tolerance
1:10	DO NOT SCALE	0.8mm
1st Angle projection	FC, 2X PRO MON P15/A15 RODAS	

