

### Interior dimensions

Width	Depth	Height
220	180	166
Weight	Approx. 9 Kg	
Wall Thickness	7mm	

### REVISIONS

ZONE	REV.	DESCRIPTION	DATE	APPROVED
-	0	Final Drawing	17/01/2016	Carlos Rodrigues

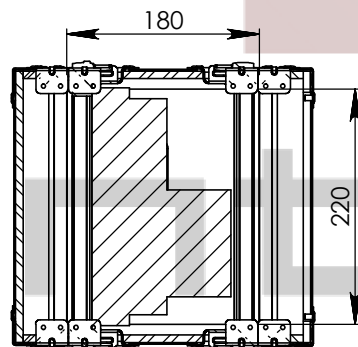
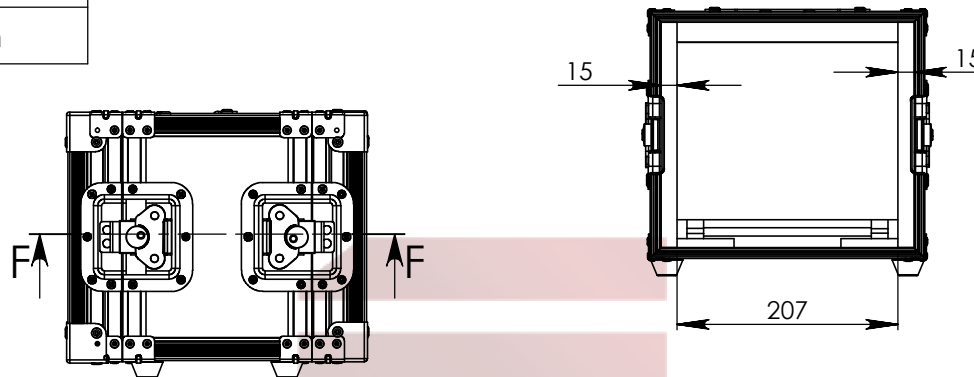
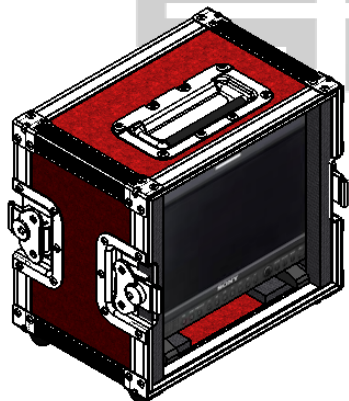
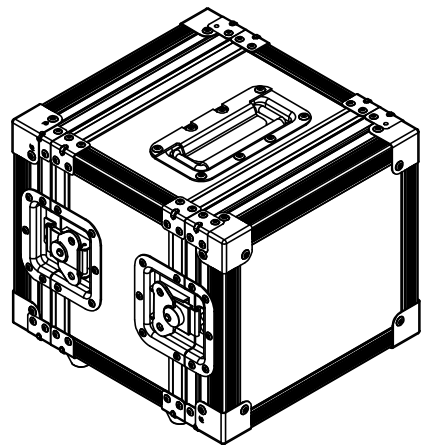

SECTION E-E

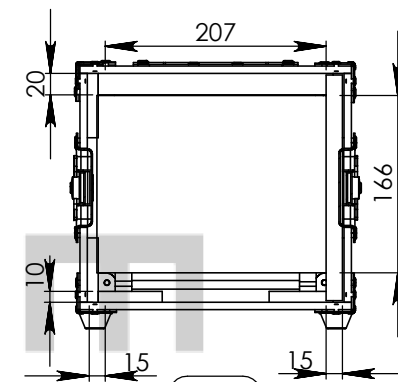

SECTION F-F

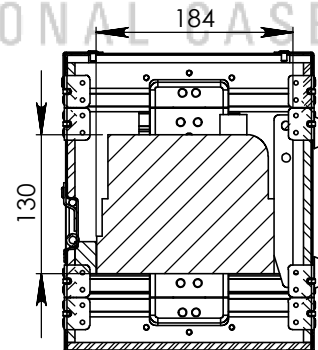

SECTION D-D

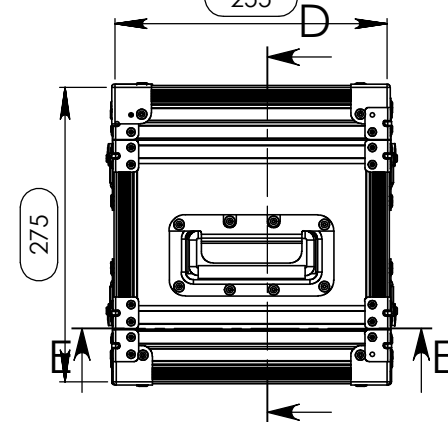

### Hardware

Qty	Ref.	Description
16	40407	Medium corner-brace zinc plated 1,0mm
4	17290S	Key lockable medium Butterfly special
1	340822	Recessed sprung handle - Small
8	4000	Square Case Corner
4	4901	Rubber foot 30 x 15mm, black

This drawing must not be copied or disclosed without consent of the owner



Scale 1:5

Scale DO NOT SCALE  
general tolerance 0.8mm

Reference	MONITOR.702E
Name	projects
Date	23/02/2016
FC ECOLINE, MONITOR SONY	941W

