

| Interior dimensions | | |
|---------------------|---------------|--------|
| Width | Depth | Height |
| 1896 | 906 | 580 |
| Weight | Approx. 71 Kg | |
| Wall Thickness | | 10mm |

| REVISIONS | | | | |
|-----------|------|---------------|------------|-----------|
| ZONE | REV. | DESCRIPTION | DATE | APPROVED |
| - | - | Final Drawing | 08/08/2016 | Alexandre |

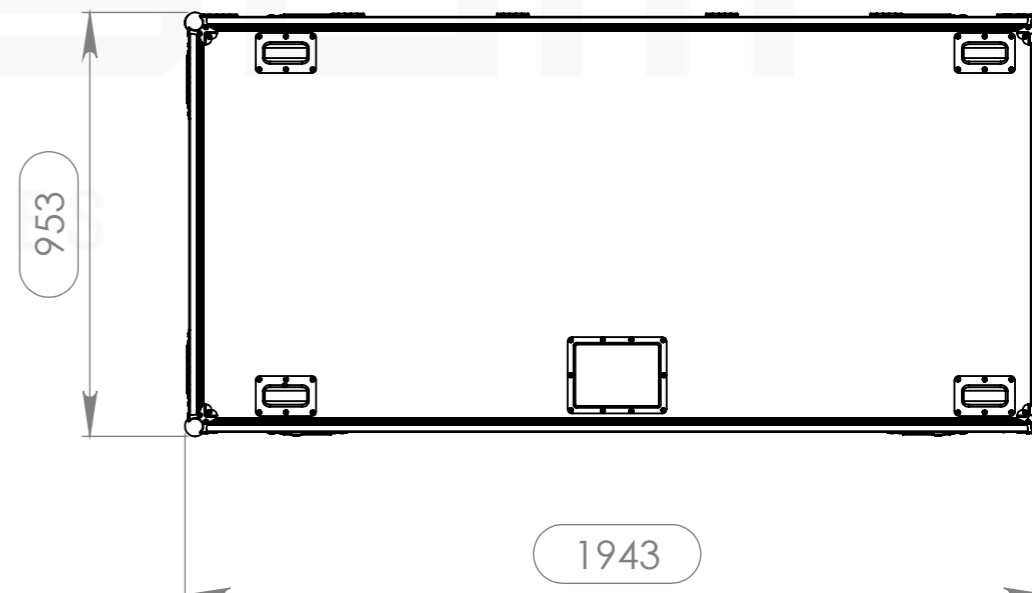
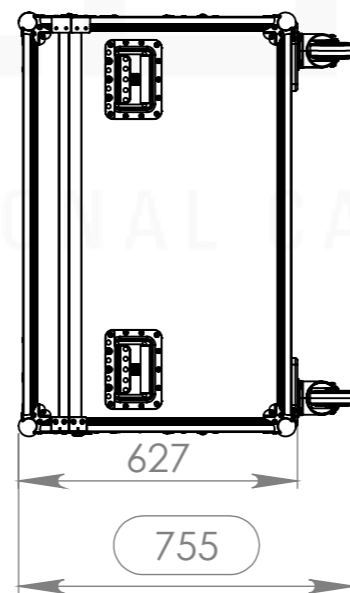
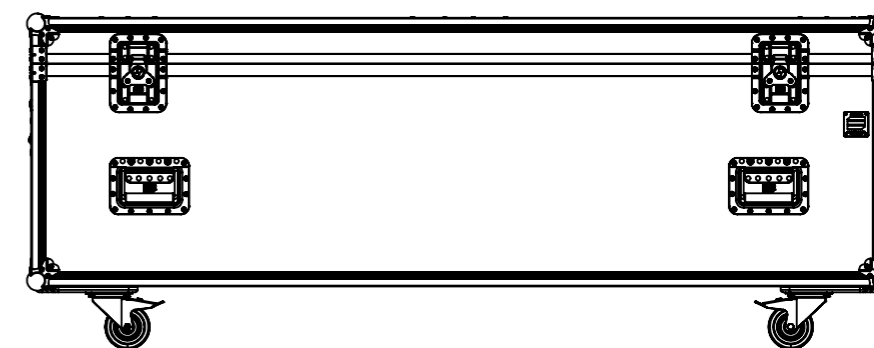
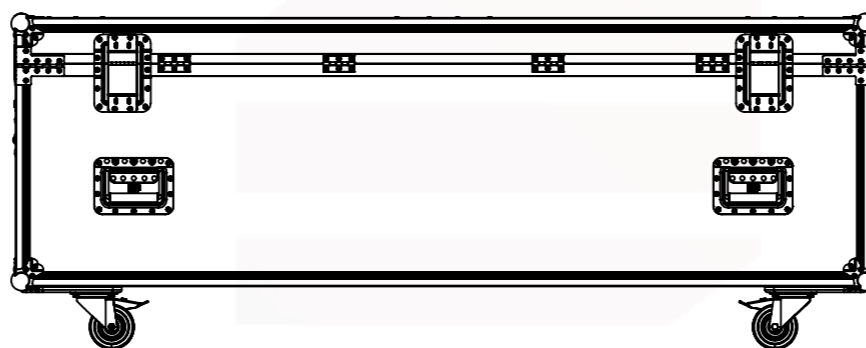
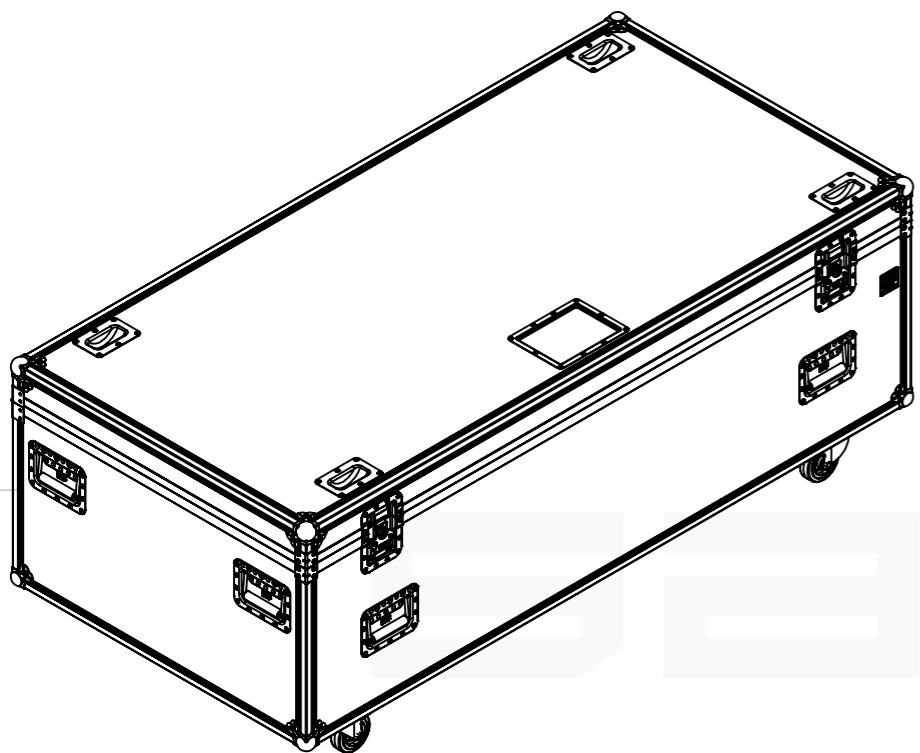

| Hardware | | |
|----------|------------|---|
| Qty | Ref. | Description |
| 4 | 40403 | Large corner bracket f. 35mm case angle |
| 8 | 410429 | Ball Corner large three-leg cranked 35 mm 9 holes |
| 8 | 34085 | Large, heavy duty, recessed sprung handle |
| 1 | 88001D | Dish for 88001 Tour Label |
| 1 | CHAPA.1000 | Identification Plate |
| 2 | 172511COMP | Large AH butterfly with 'push-back', 14mm dish |
| 2 | 270836 | Large lidstay cranked / hinge |
| 2 | RODA.100T | Swivel castor Ø100mm with brake |
| 2 | RODA.100 | Swivel castor Ø100 mm |
| 4 | 38083 | Castor dish deep zinc plated |
| 2 | DCR110 | 110MM hinge shot |
| 4 | 2602 | Medium duty butt hinge z./p. |

A3 This drawing must not be copied or disclosed without consent of the owner

| | | | |
|----------------------|-----------|-------------------------------------|-------------------------|
| Drawn by | alexandre | Date | 08/08/2016 |
| Reference | MLX.1900A | | |
| Scale | 1:17 | units in mm | general tolerance 0.8mm |
| 1st Angle projection | | PRO TRUNK MLX-1900A, 1895X905X580MM | |

