

Dimensões

Comprimento	Largura	Altura
1400	525	1043
Peso	Approx. 91 Kg	
Espessura	10mm	

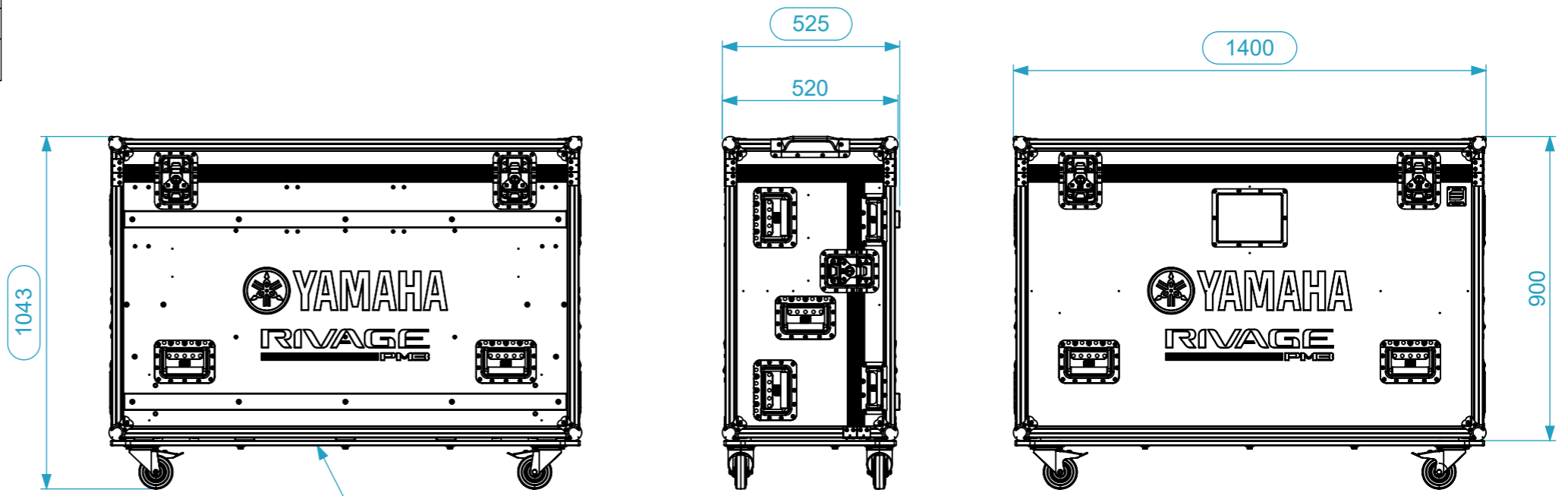
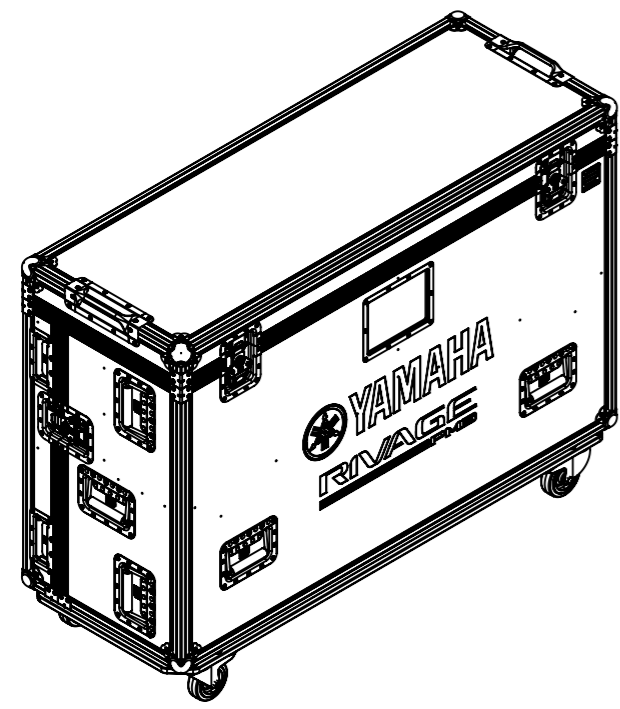

Lista de Componentes

Item nº	Quant.	Descrição	Ref.
1	4	Asa Mola Pequena	340822
2	10	Asa de mola grande - zincado	34085
3	8	Canto de bola grande com rebaixo 2mm - 9 furos	410429
4	12	Remate grande em L - zincado	40403
5	9	PORCA C/GARRA M8	DIN6919.M8.ZC
6	1	Chapa Santosom	CHAPA.1000
7	1	Painel para label	88001D
8	2	ASA DE ANGULO - ZINCADO	34041
9	5	Pé Plastico 58x45x10mm	PES.5845
10	8	Fecho borboleta " Push Back " - zincado	172511PEN
11	10	PARAFUSO EMB. SEXT.INT.M6X25 OXI	DIN7991.M625.OX
12	34	PORCA C/GARRA M6	DIN6919.M6.ZC
13	1	SUPORTE TECLADO E RATO 430x200 PARA MIXER	SUPORTE.1045
14	2	SUPORTE MICRO / HEADPHONES PARA MIXER	SUPORTE.1041
15	1	Espuma p/ Logitech Teclado Wireless K400 Plus	EHD.450
16	6	Rebite POP 4,8x20 - Preto	DIN7337.0520.LP
17	1	Skate Fixo, 1400x520mm p/ FC Régua 110	R3.14052
18	2	Suporte com braço giratório	GSA6131B
19	2	PARAFUSO EMB. SEXT.INT.M6X30 OXI	DIN7991.M630.OX
20	10	PARAFUSO EMB. SEXT.INT.M6X50 OXI	DIN7991.M650.OX
21	4	PARAFUSO EMB. SEXT.INT.M8X25 OXI	DIN7991.M825.OX
22	8	PARAFUSO COMBI CABEÇA OVAL M4X25 - Oxidado	DIN0082.M425.OX

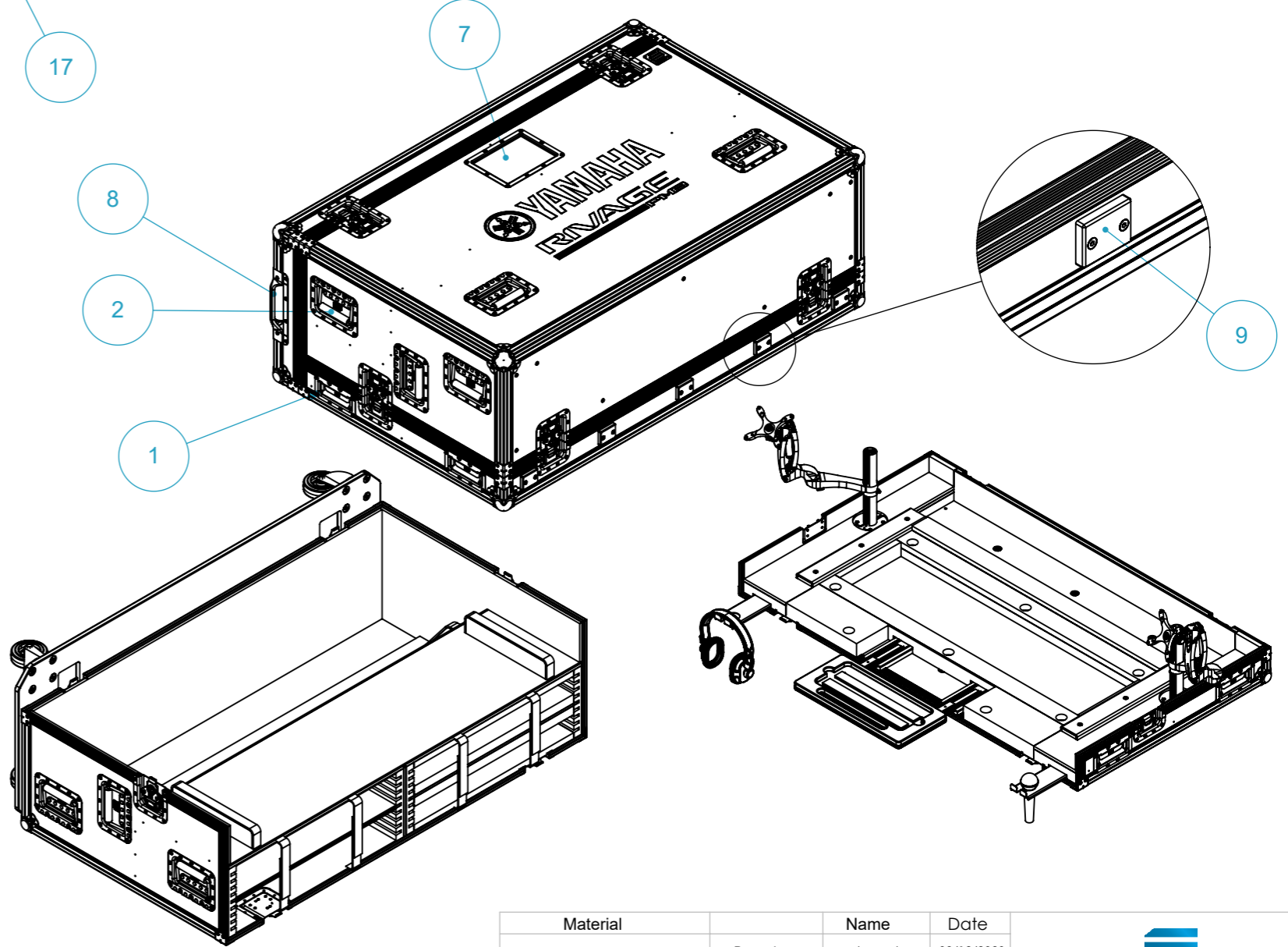

Material	Name	Date
	alexandre	09/12/2020
Reference	MIXER.653P31.A10	
This drawing must not be copied or disclosed without consent of the owner	Scale	units in mm
	1:17	DO NOT SCALE
1st Angle projection	general tolerance	0.8mm
	Flight case X33MR PRO-3.1, Yamaha Rivage PM3 CS-R3	

