

Interior dimensions

Width	Depth	Height
798	553	350
Weight	Approx. 9 Kg	
Wall Thickness	10mm	

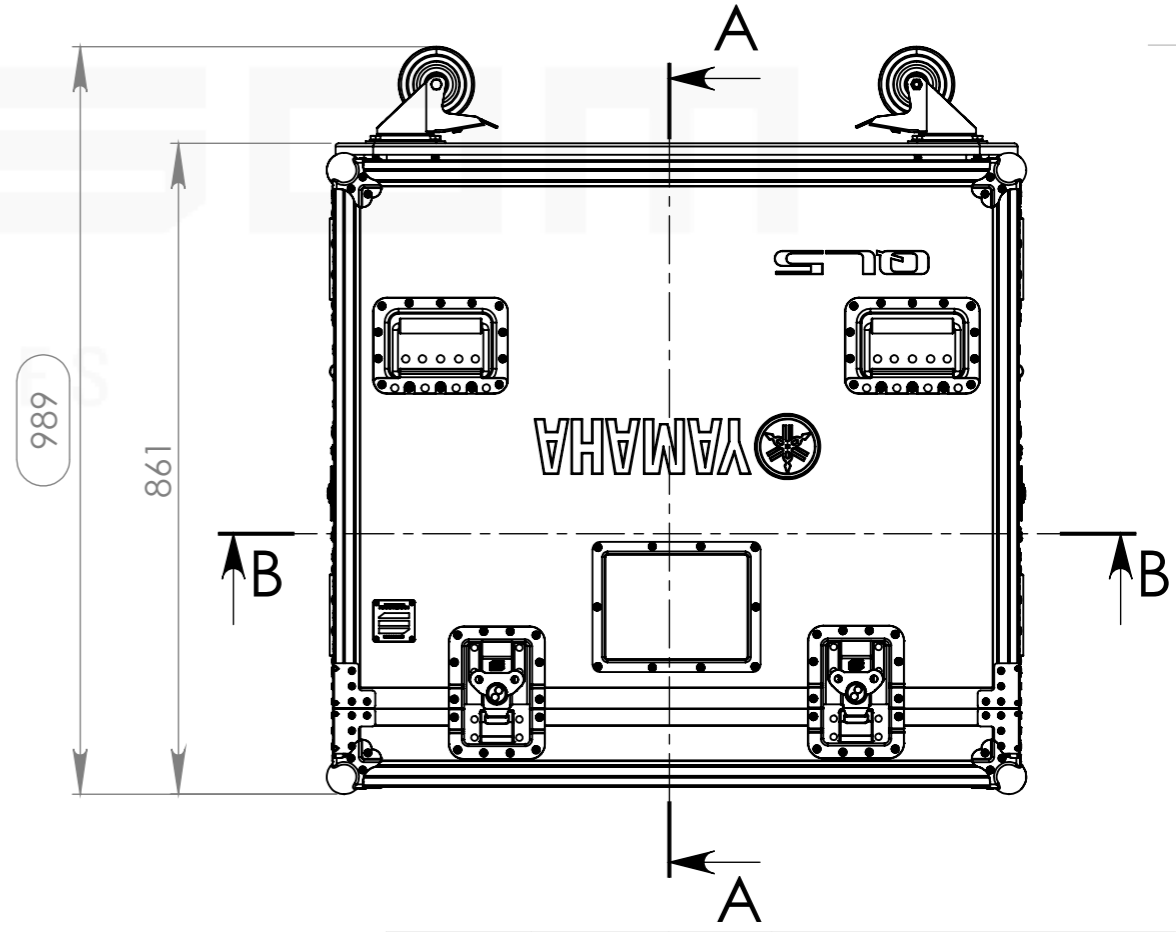
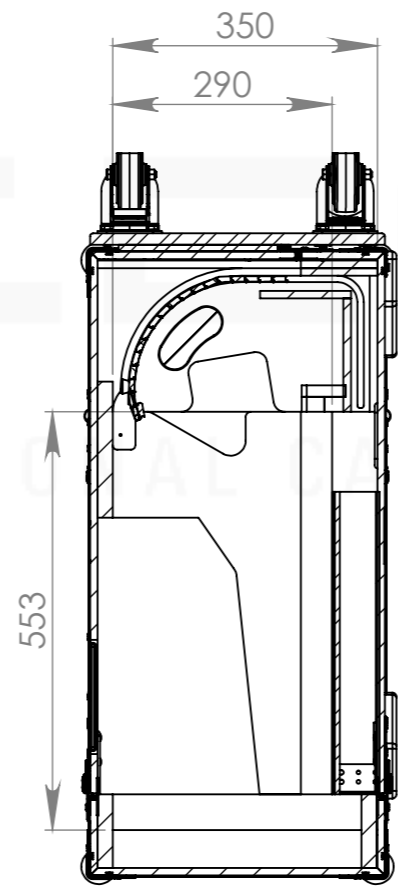
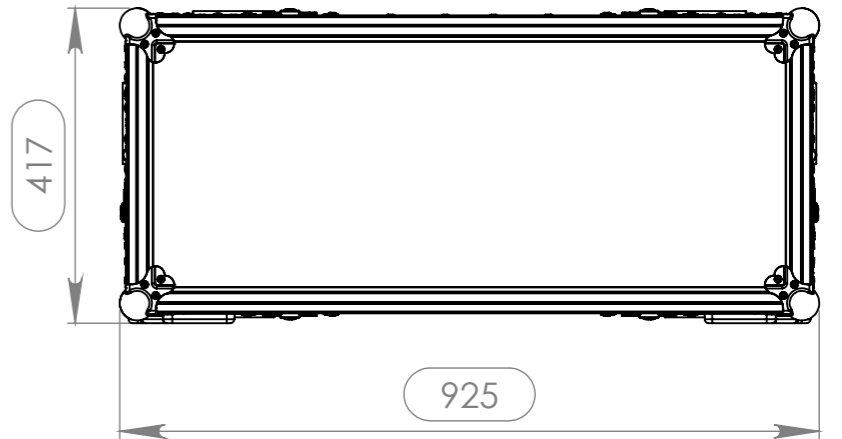
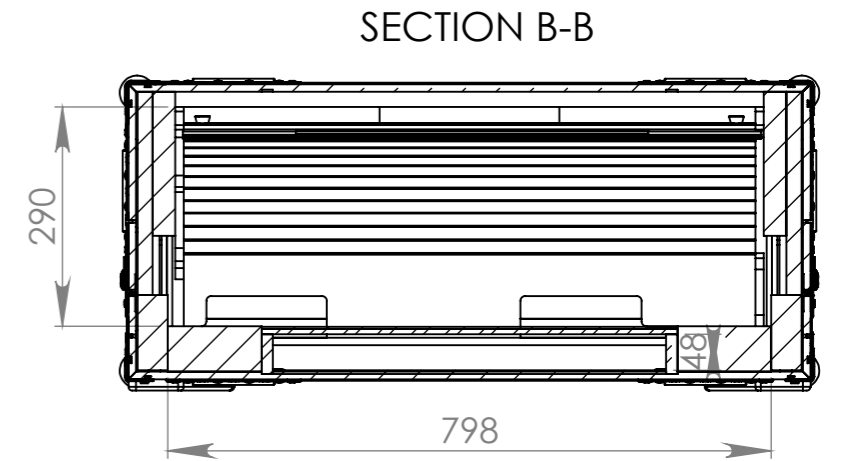
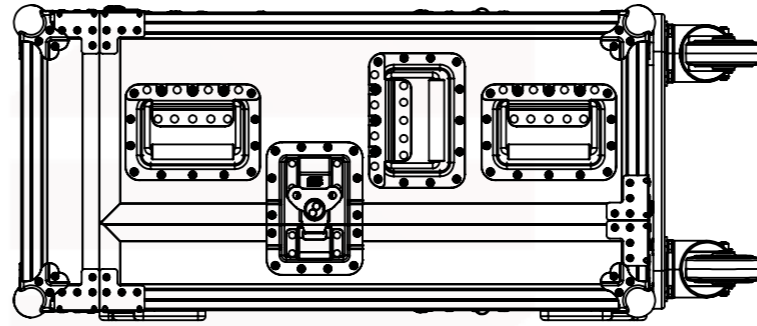
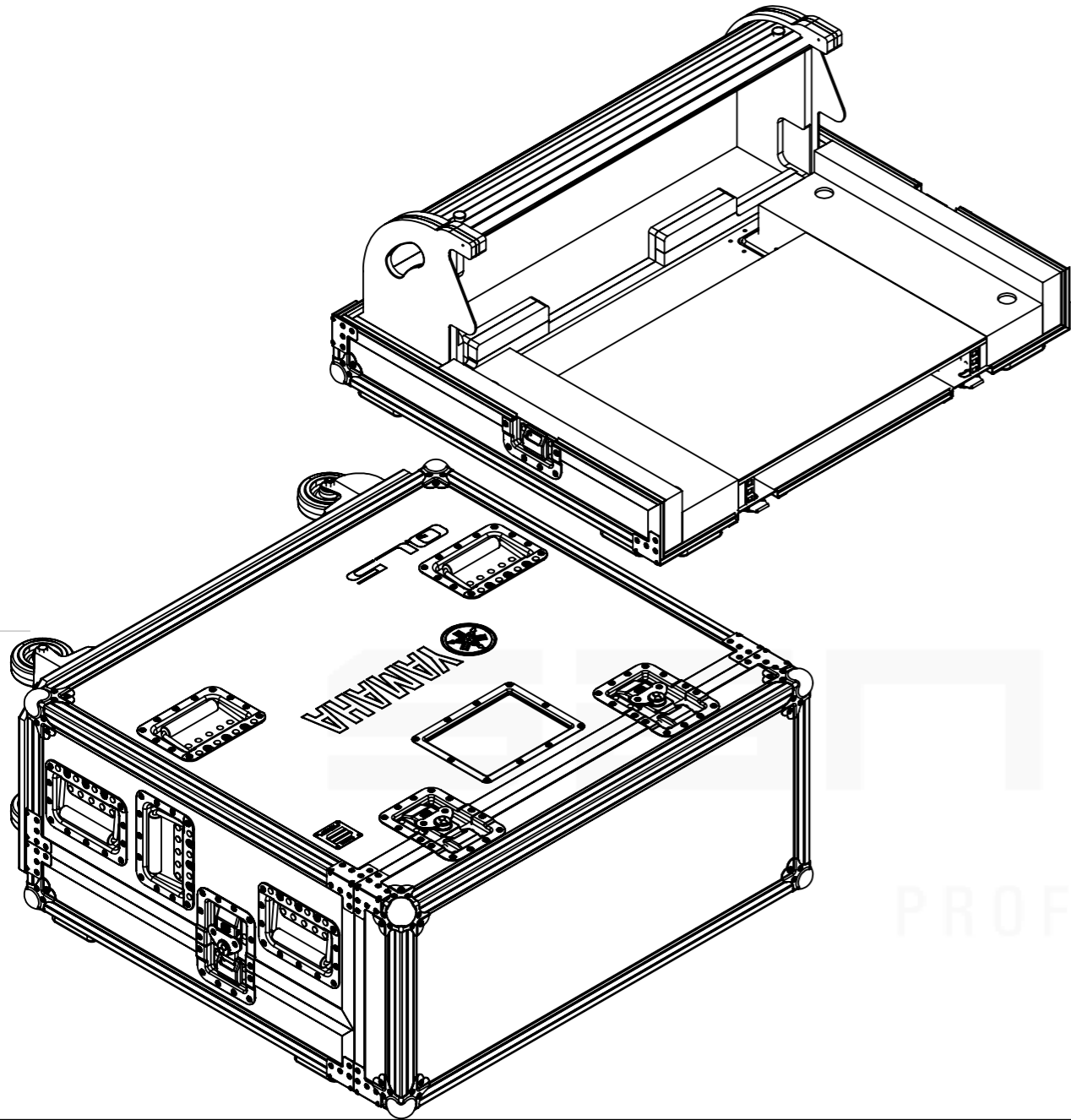

Qty	Hardware Description
12	Large cranked corner brace to suit deep side of locations and 35 mm angels
8	Heavy Duty Ball Corner
6	Large AH butterfly with 'push-back', 14mm dish
10	Large, heavy duty, recessed sprung handle
1	Dish for 88001 Tour Label
2	Swivel castor Ø100mm with brake
2	Swivel castor Ø100 mm
2	Large butterfly V3 with 'push-back' function

SECTION A-A

SECTION B-B

Drawn by	Name	Date
projects		30/03/2017
Reference	MIXER.478SFA	
Scale	units in mm	general tolerance
1:10	DO NOT SCALE	0.8mm
FC 21, YAMAHA	QL5, MÓVEL, RODAS	



This drawing must not be copied or disclosed without consent of the owner

1st Angle projection

A3