

Exterior dimensions

Width	Depth	Height
560	705	374
Weight	Approx. 20 Kg	
Wall Thickness	10mm	

Hardware		
Qty	Ref.	Description
8	410429	Heavy Duty Ball Corner
8	40403	Large corner bracket f. 35mm case angle
1	88001D	Dish for 88001 Tour Label
4	34082	Recessed Sprung Handle Medium
Options available (not included in the case Standard)		
1	MIXER.477.A01	Skate for FC, YAMAHA QL1

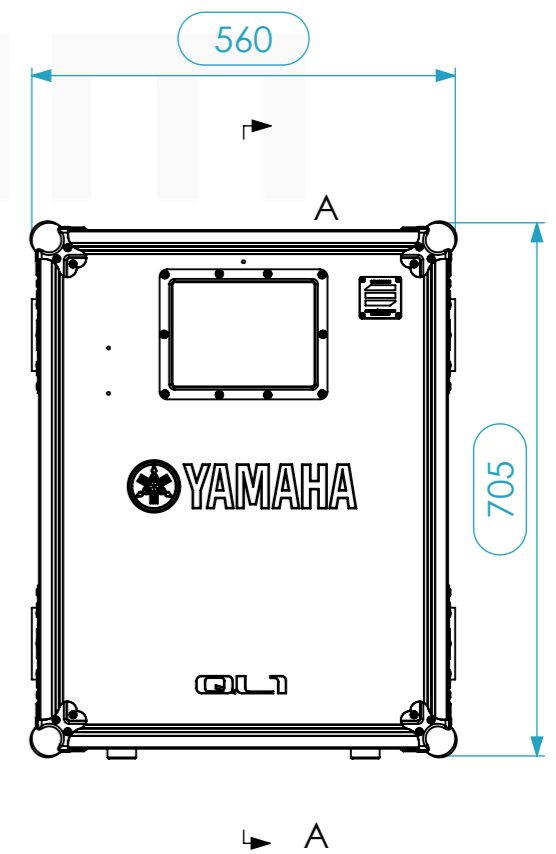
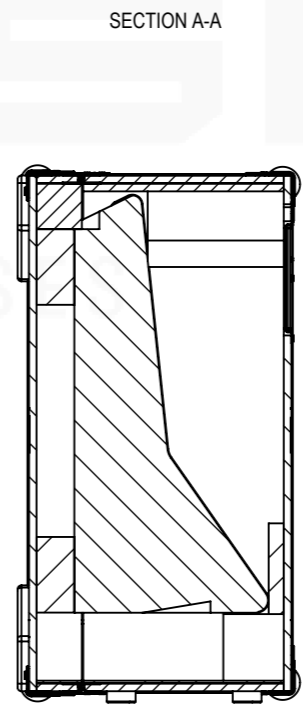
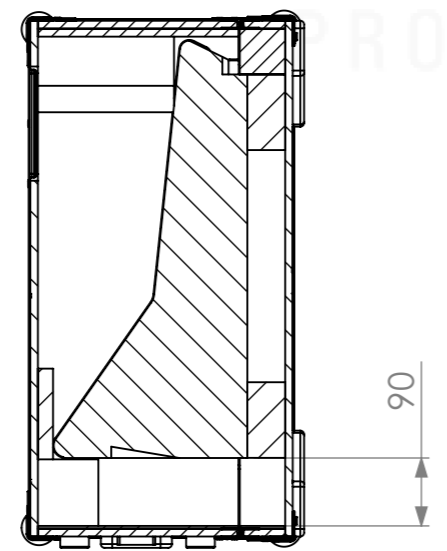
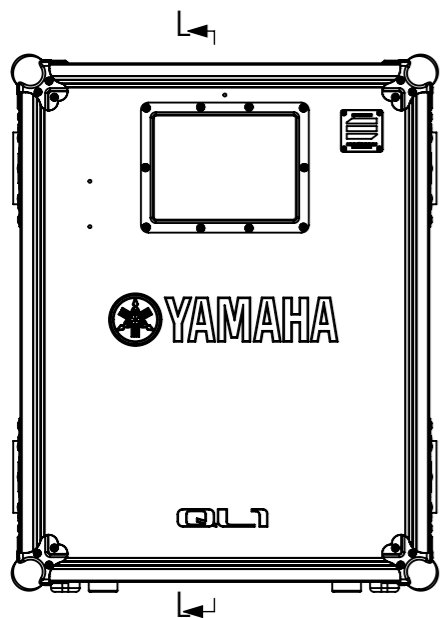
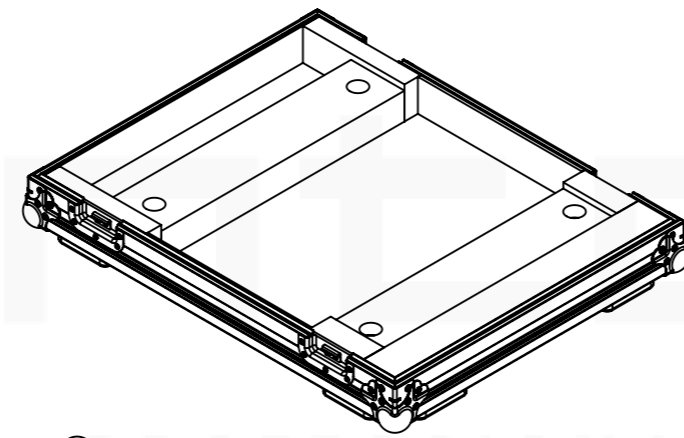
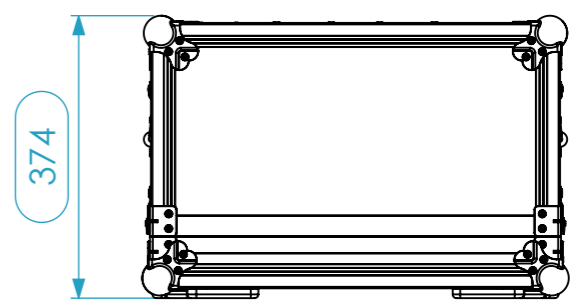
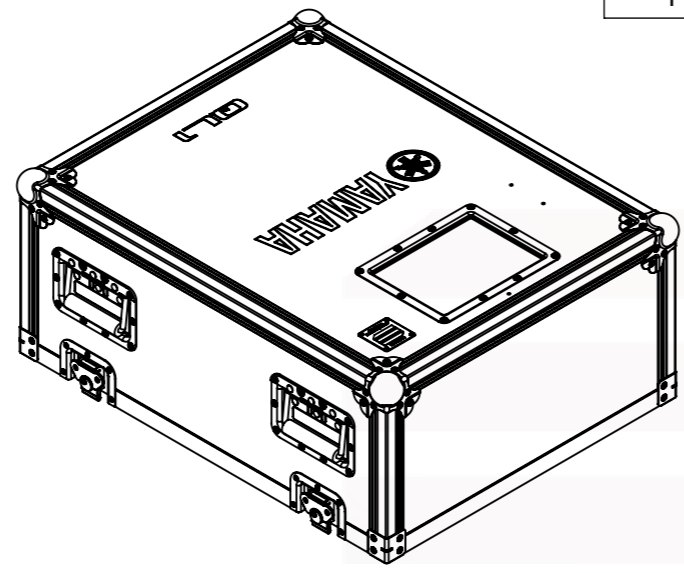
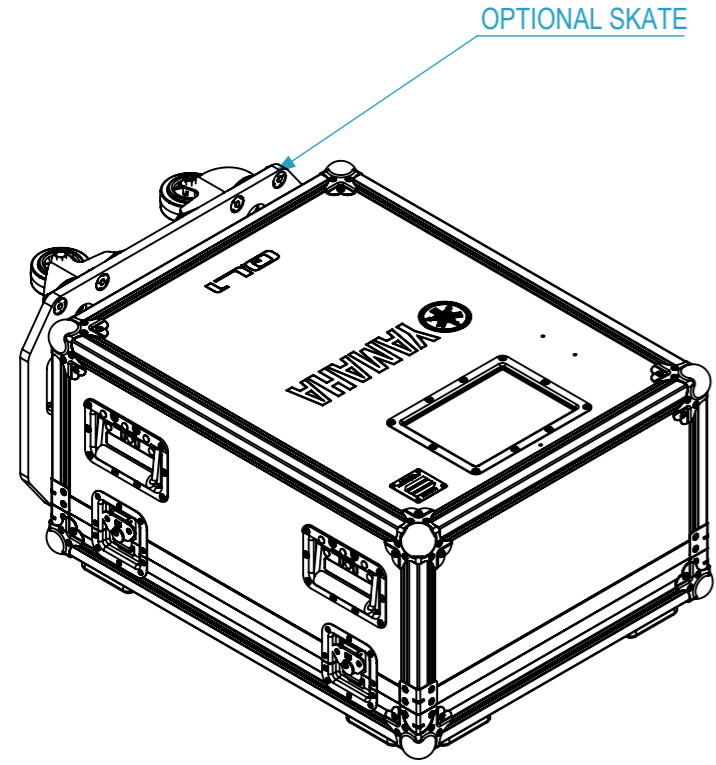

Drawn by	Name	Date
CarlaSilva	CarlaSilva	09/11/2017
Reference	MIXER.477E	
Scale	units in mm	general tolerance
1:10	DO NOT SCALE	0.8mm
1st Angle projection	FC, YAMAHA QL1 Digital Mixer	



This drawing must not be copied or disclosed without consent of the owner

A3