

Equipment			ALLEN & HEATH WZ		
Width	Depth	Height			
507	530	195			
Internal Dimensions					
Width	Depth	Height			
563	563	226			
Weight	Approx. 11.01 Kg				
Wall Thickness	7mm				

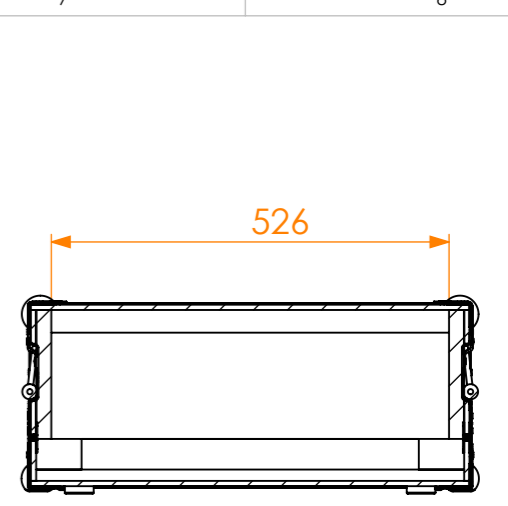

SECTION B-B

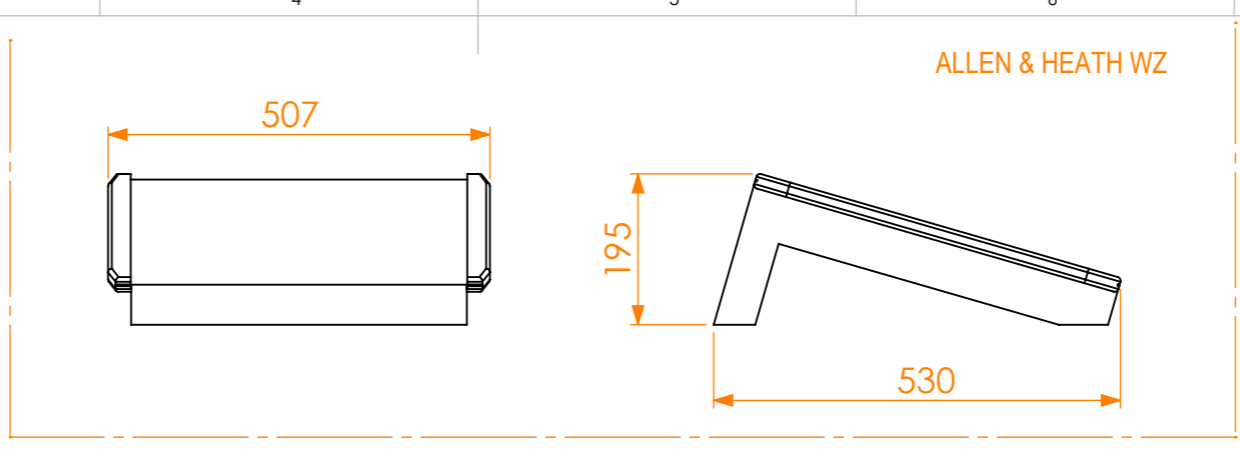
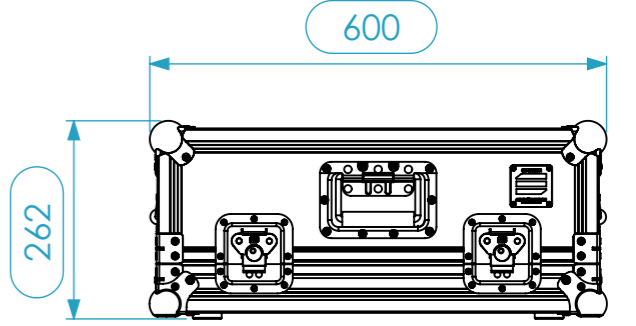
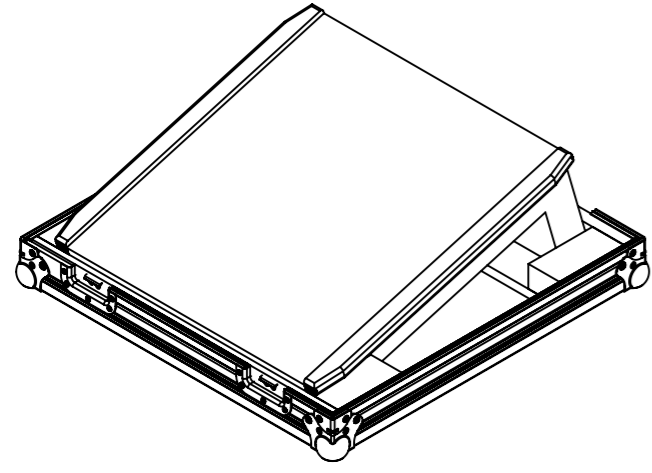

A ←

eggbox foam (presses 10mm)

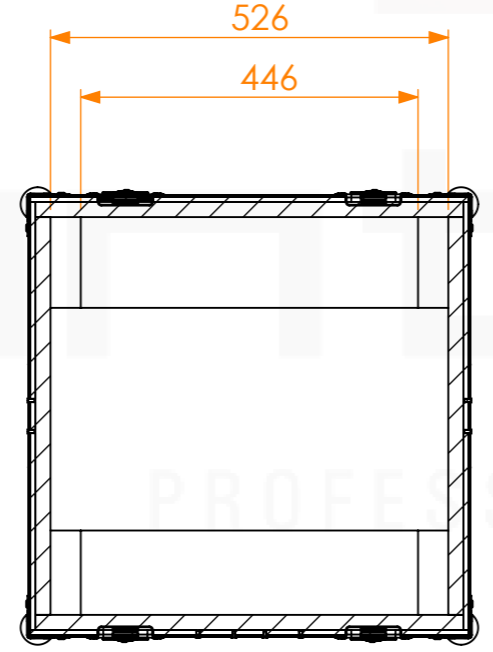

C-C

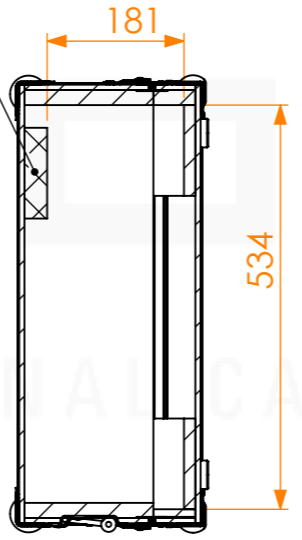

SECTION A-A

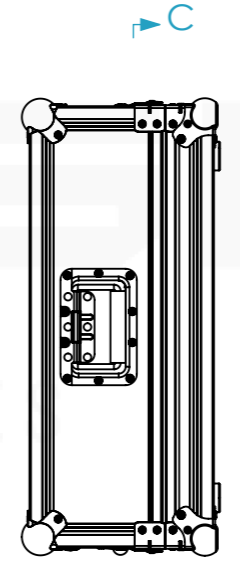

← C

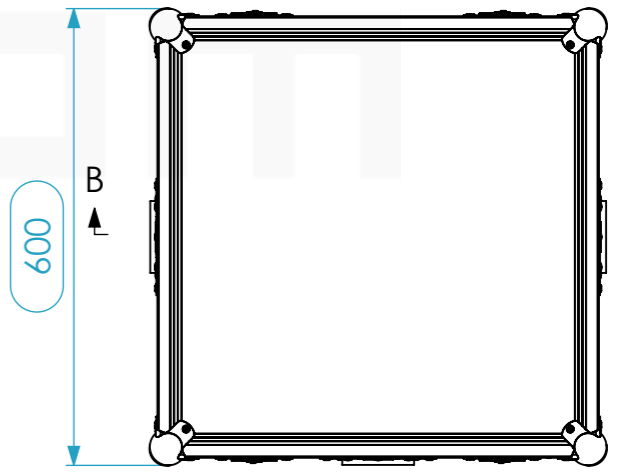

A ←

Hardware		
Qty	Ref.	Description
4	4122	Medium ball corner zinc plated with stacking dimple
8	40403	Large corner bracket f. 35mm case angle
4	4120	Heavy duty ball corner, zinc plated
1	CHAPA.1000	Identification Plate
3	34082	Recessed Sprung Handle Medium
4	17290S	Key lockable medium Butterfly special
4	4906	38 mm rubber foot black H:10 mm.

A3

This drawing must not be copied or disclosed without consent of the owner



Scale 1:10  
units in mm DO NOT SCALE  
general tolerance 0.8mm  
FLIGHT CASE, ALLEN & HEATH WZ

Name	Date
CarlaSilva	31/01/2018
Reference	MIXER.453

