

Dimensions

Width	Depth	Height
390	80	53
Weight	Approx. 6 Kg	
Wall Thickness		7mm

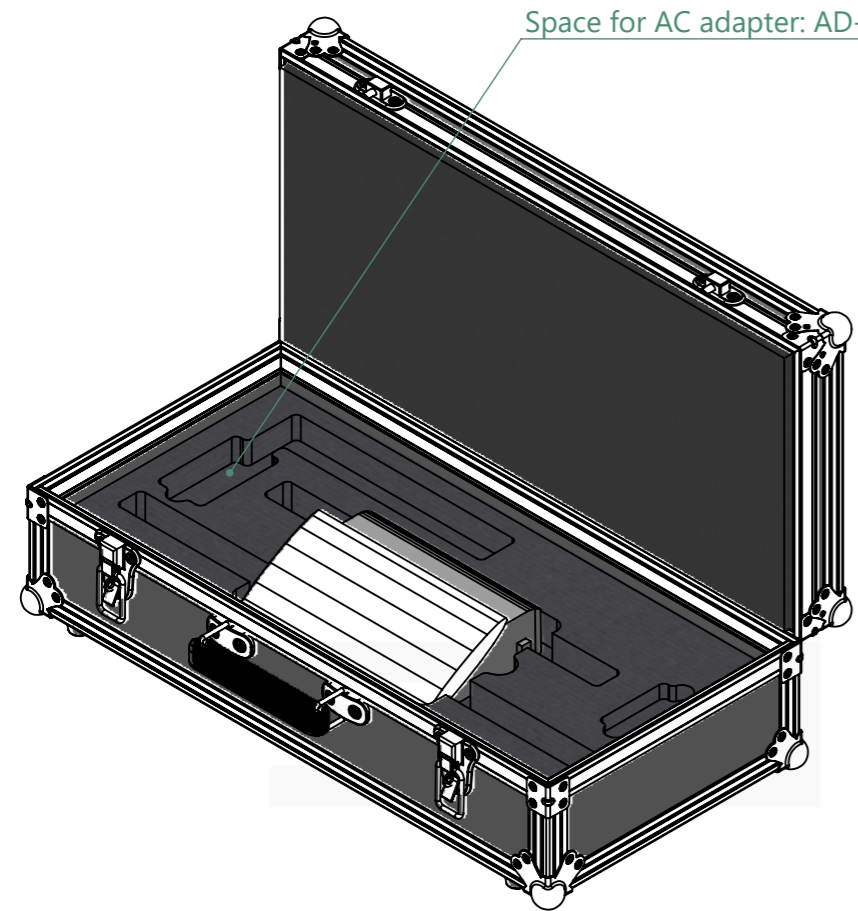

EggBox Foam

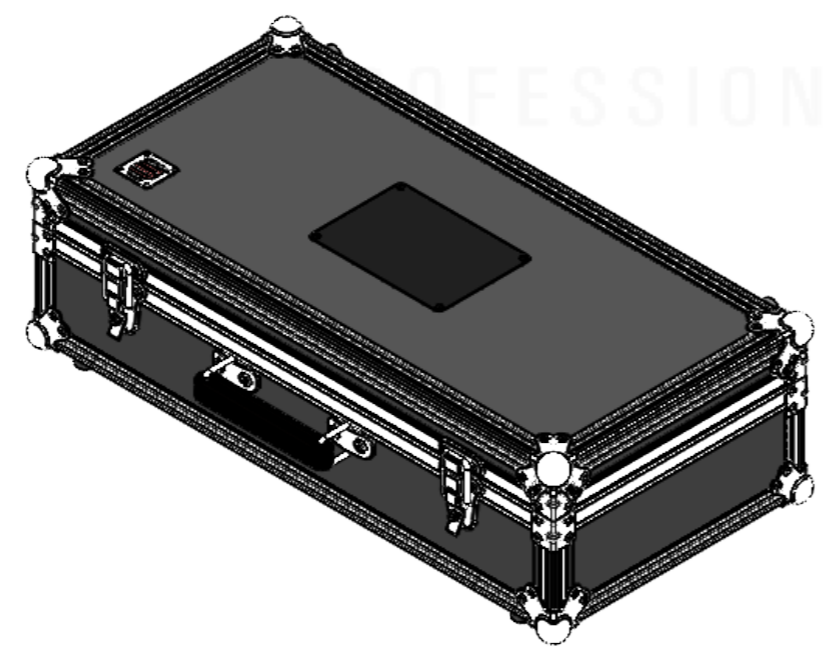
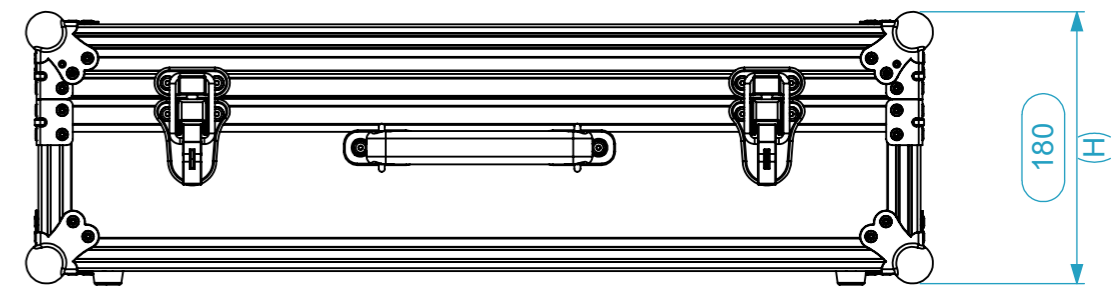
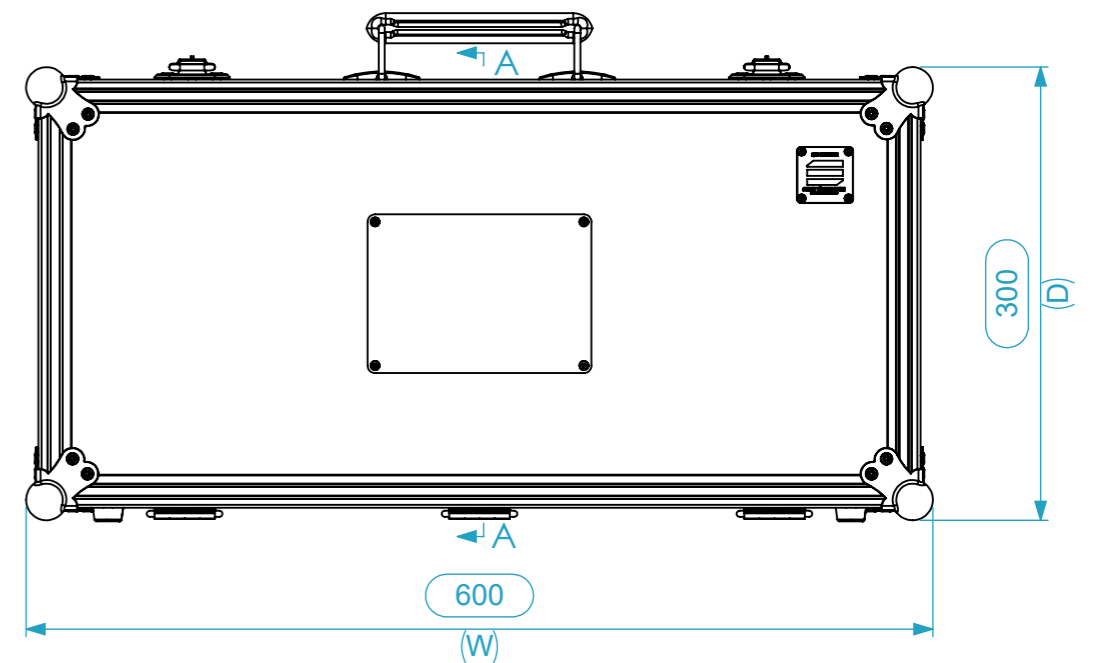
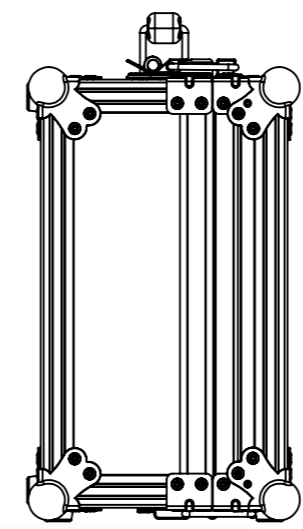
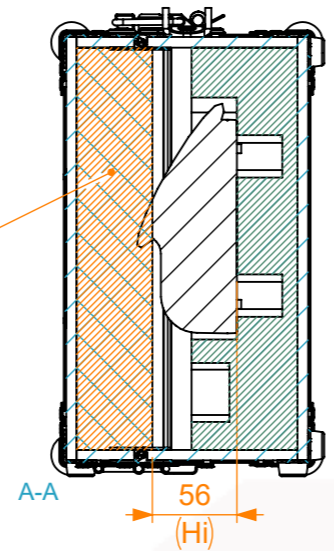

Space for Microphone: TS-903 / TS-904

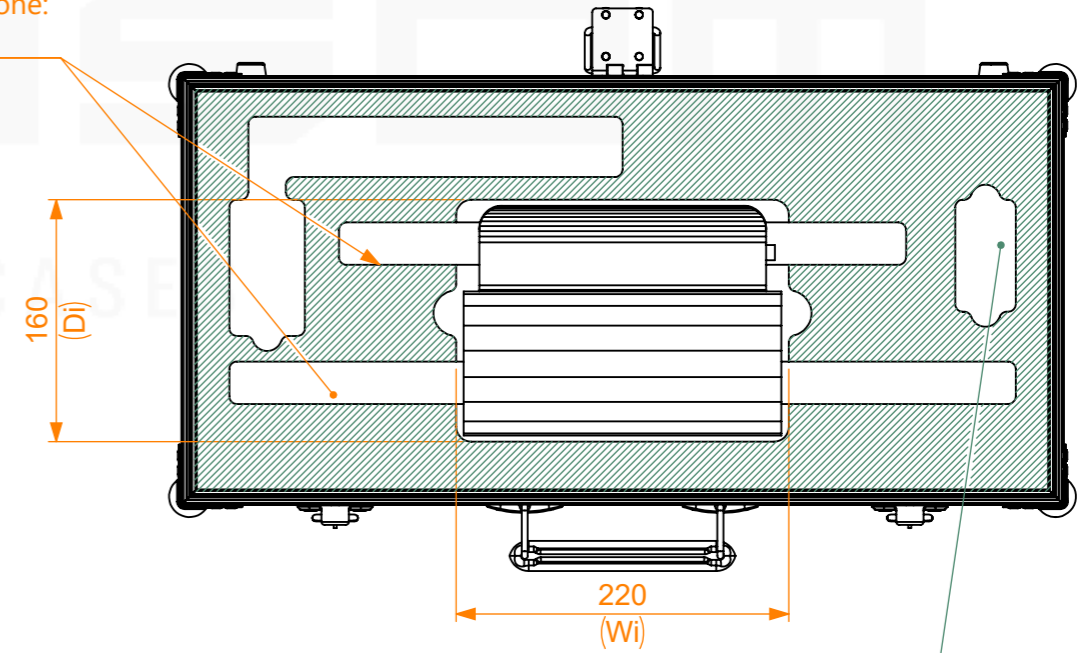

Space for battery: BP-900

General External Dimensions		Usable Inner Dimensions	
W	Width	Wi	Inside Width
D	Depth	Di	Inside Depth
H	Height	Hi	Inside Height

This drawing must not be copied or disclosed without consent of the owner

Drawn by	Name	Date
fiago.pais	fiago.pais	27/05/2026
Reference	MICRO.412	
Scale	units in mm	general tolerance
1:5	DO NOT SCALE	0.8mm
Trunk M1 55.44.30 Central TOA TS-901		

