

Internal Dimensions		
Width	Depth	Height
1103	363	306
Weight	Approx. 13 Kg	
Wall Thickness		7 mm

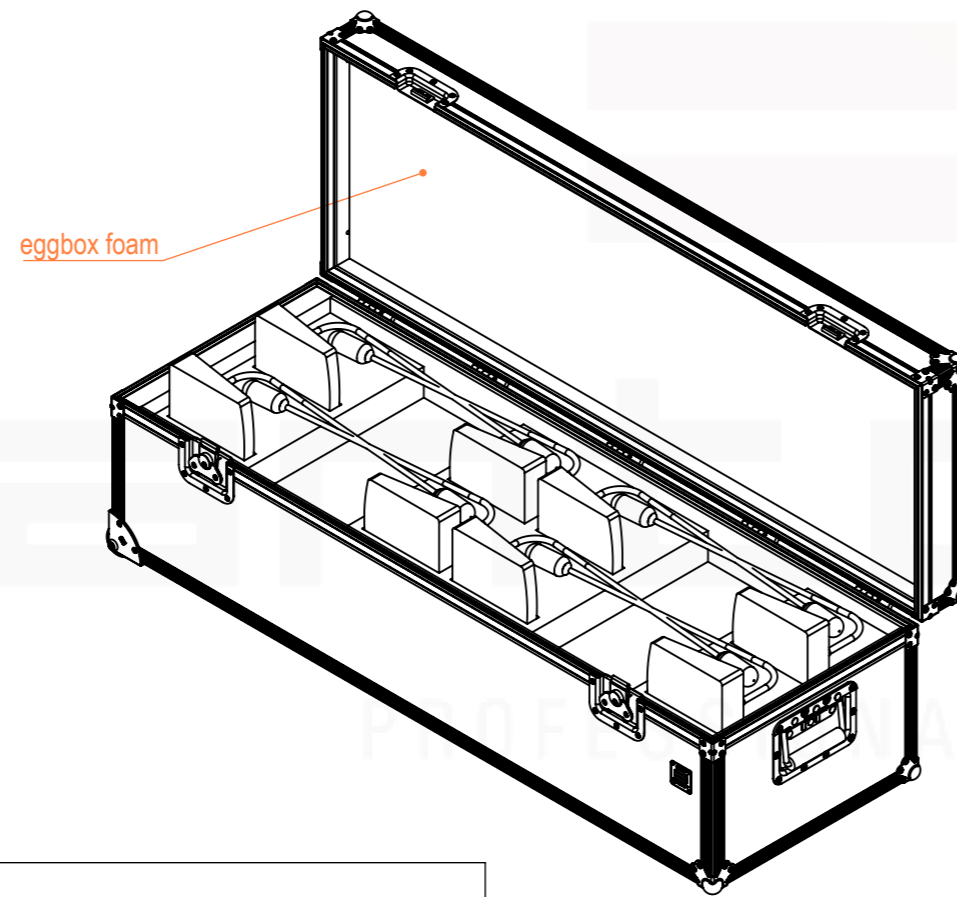
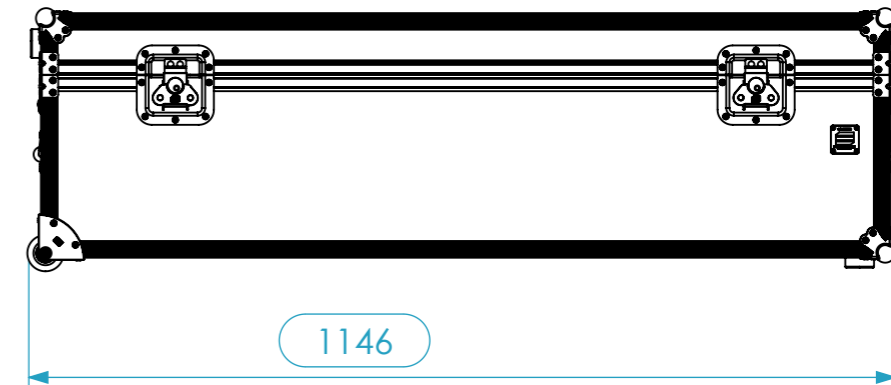
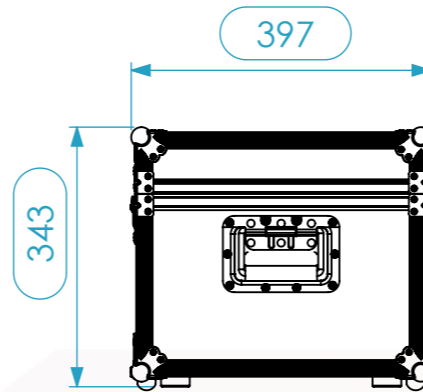
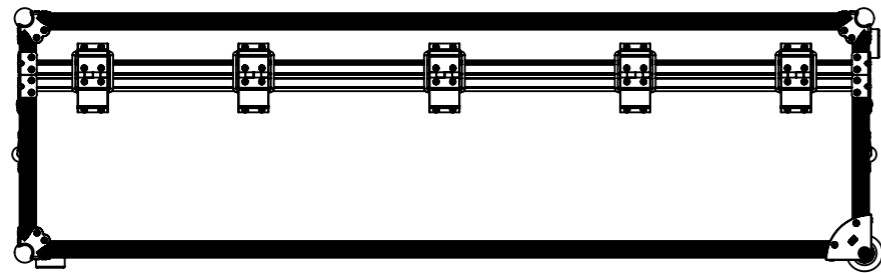

Hardware		
Qty	Ref.	Description
8	40407	Medium corner-brace zinc plated 1,0mm
6	C1345Z	Small ball corner - 3 leg - zinc plated
1	CHAPA.1001	Identification Plate
2	34082	Recessed Sprung Handle Medium
2	17290S	Key lockable medium Butterfly special
4	4907	Rubber foot 38mm x 15 mm
5	2524	Heavy Duty Strut Hinge
2	37600S	Castor with 48 mm wheel in aluminium

A3

This drawing must not be copied or disclosed without consent of the owner



Scale 1:10

units in mm
DO NOT SCALE
general tolerance 0.8mm

Drawn by	Name	Date
CarlaSilva	CarlaSilva	06/12/2017
Reference	MICRO.406	

FLIGHTCASE, 16X BEYERDYNAMIC GM 115Q + MU21/M3

