

Interior dimensions		
Width	Depth	Height
19"	250	3Un
Weight	Approx. 8 Kg	
Wall Thickness	7mm	

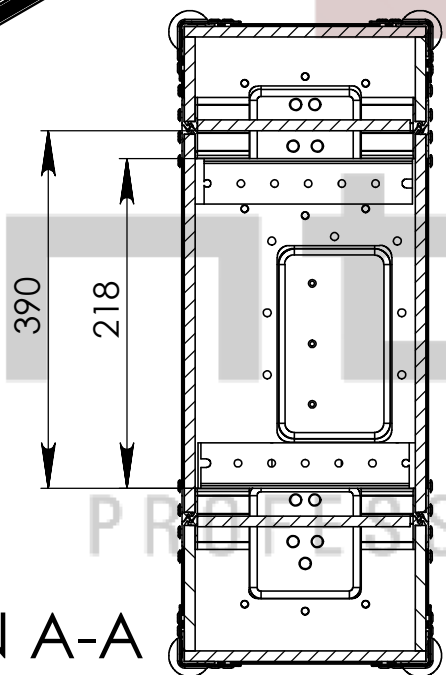

SECTION A-A

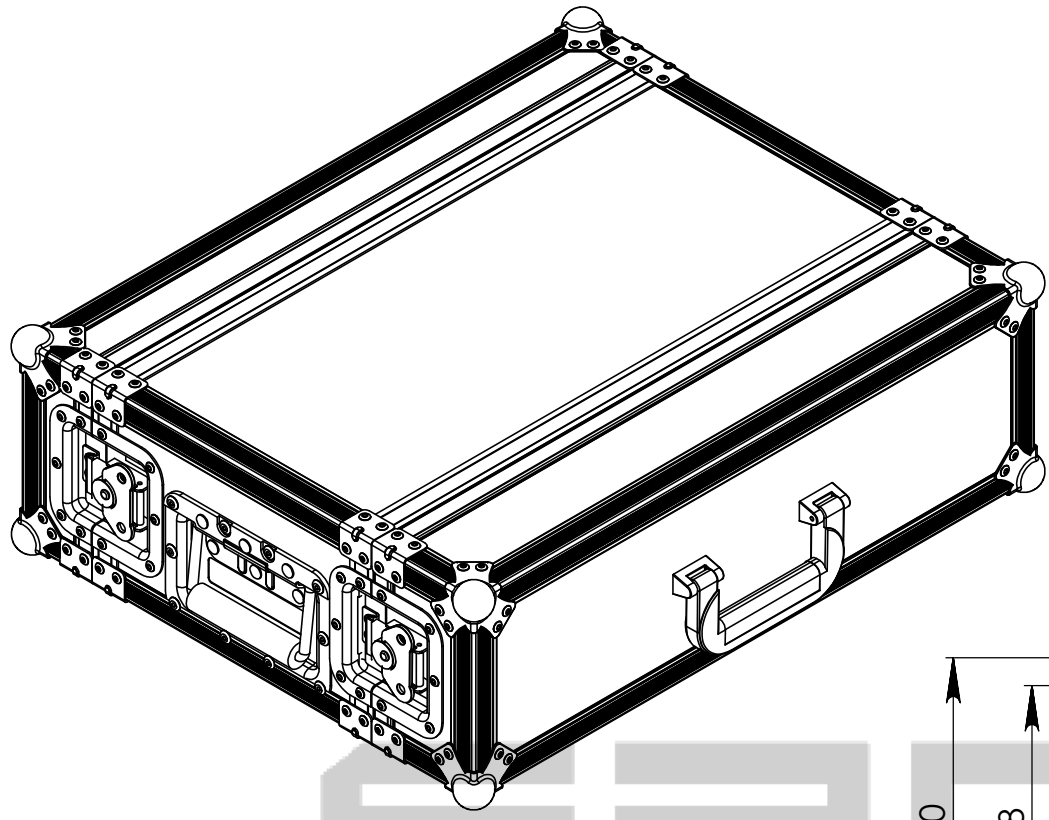
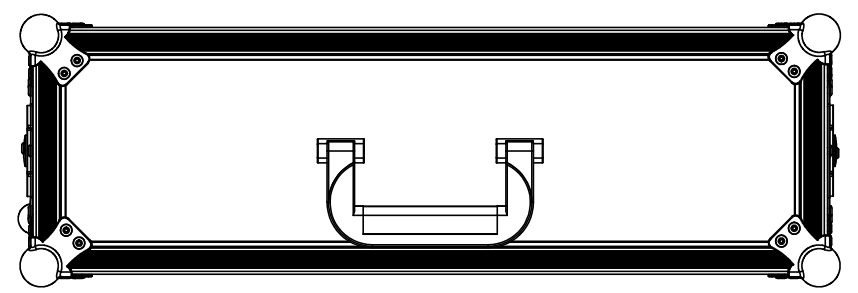
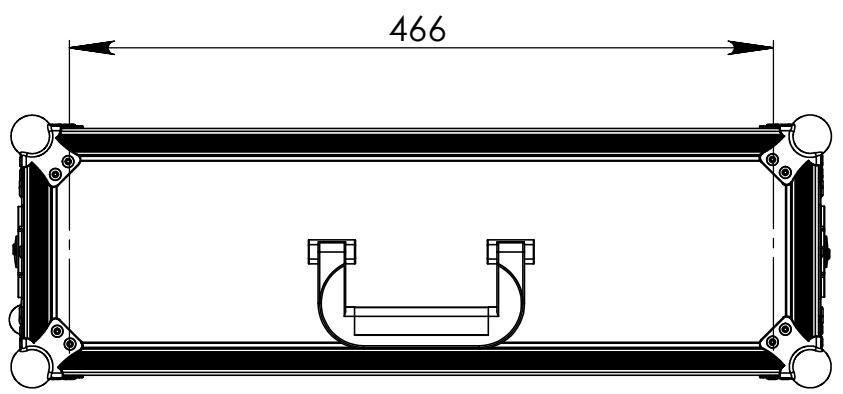
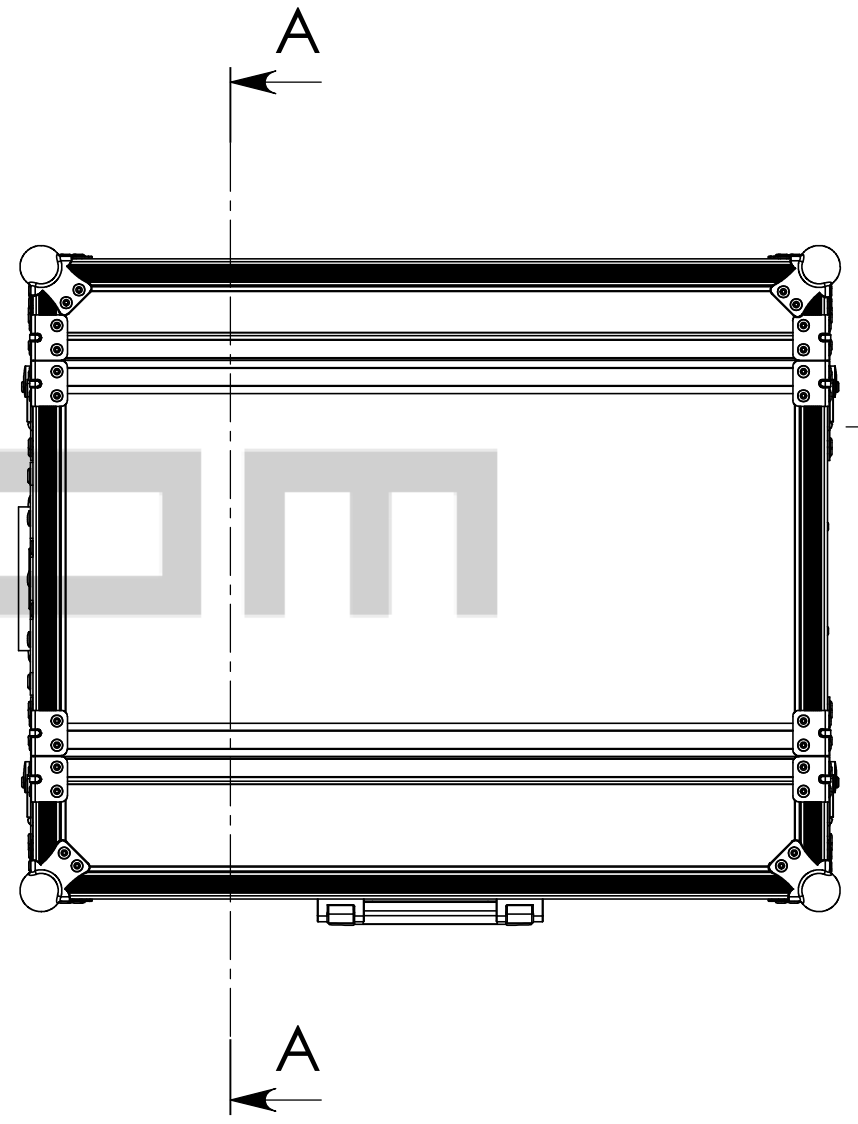
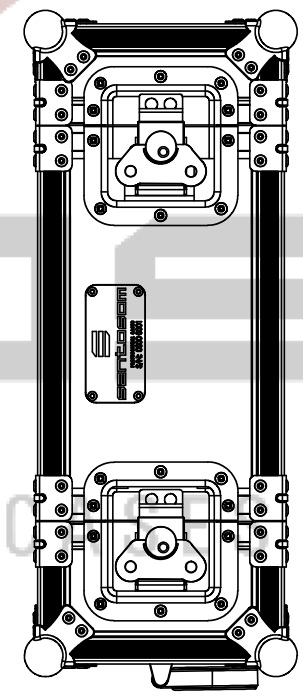

Hardware		
Qty	Ref.	Description
16	40407	Medium corner-brace zinc plated 1,0mm
8	4112	Small ball corner - 3 leg - zinc plated
4	4903	Rubber foot 20 x 9 mm, black
4	17290S	Key lockable medium Butterfly special
1	34082	Recessed sprung handle medium model
1	3430	Chrome plated plastic with soft black plastic insert

This drawing must not be copied or disclosed without consent of the owner

Drawn by	Name	Date
pedroneves	pedroneves	14-10-2013
Reference	MICRO.400	
Scale	units in mm	general tolerance
1:5	DO NOT SCALE	0,8mm
RACK 19" 2 TAMPAS 3U 250 PROF.		

