

Internal Dimensions		
Width	Depth	Height
483	303	206
Weight	Approx. 4 kg	
Wall Thickness	7mm	

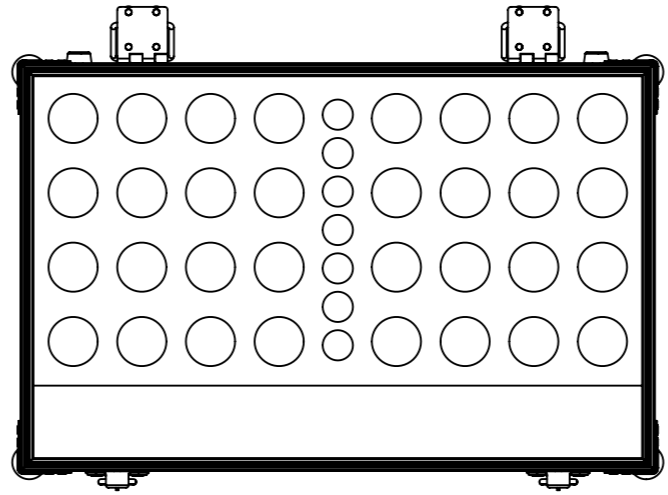
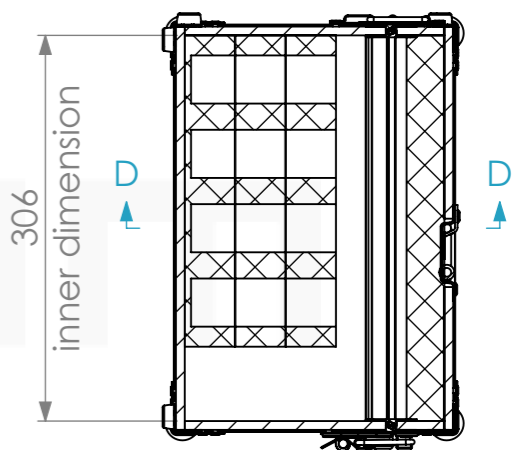
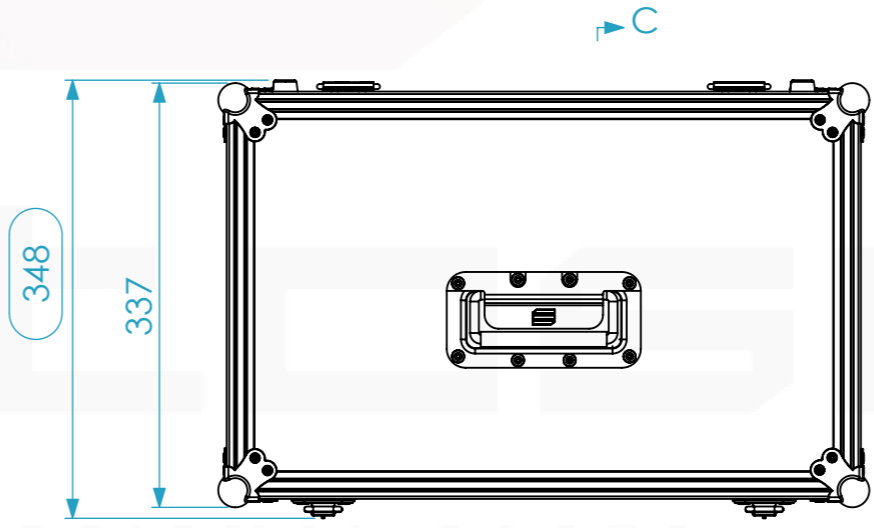
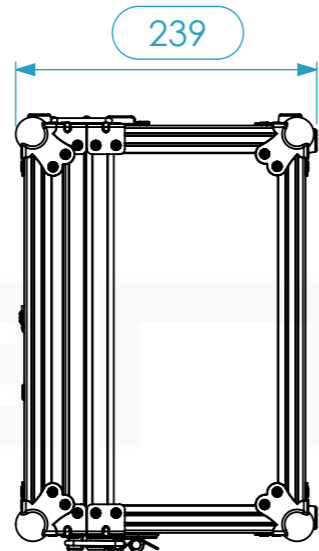
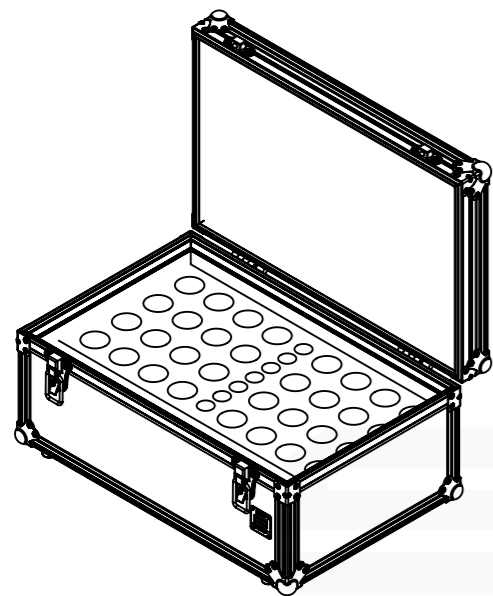
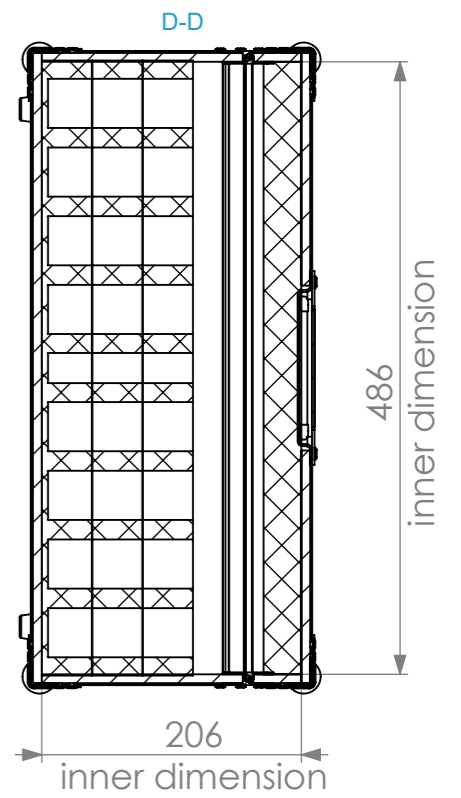
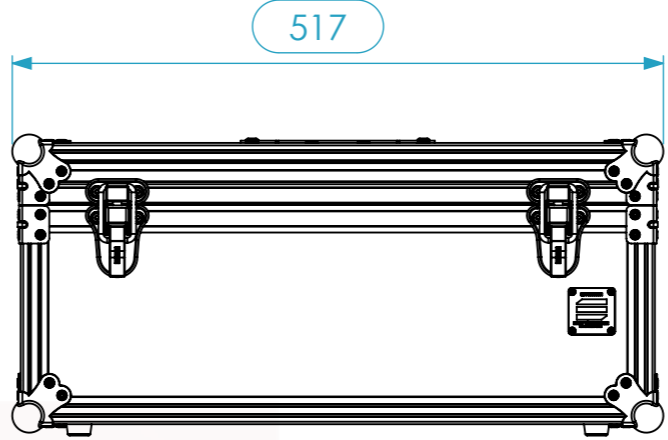

Hardware		
Qty	Ref.	Description
8	40407	Medium corner-brace zinc plated 1,0mm
2	2524	HEAVY DUTY STRUT HINGE WITH BLACK PLATE
8	C1345Z	Small ball corner - 3 leg - zinc plated
8	4903	Rubber foot 20 x 9 mm, black
1	340822	Recessed sprung handle - Small
1	CHAPA.1001	Identification Plate
2	16021	Large padlocking drawbolt

A3 This drawing must not be copied or disclosed without consent of the owner

Drawn by	Name	Date
CarlaSilva	CarlaSilva	11/12/2017
Reference	MICRO.039	
Scale	units in mm	general tolerance
1:6	DO NOT SCALE	0.8mm
1st Angle projection	FLIGHTCASE, 39X MICROPHONES + ACCESS.	

