

Equipment	MARTIN MAC 250 BEAM	
Width	Depth	Height
315	395	610
Internal Dimensions		
Width	Depth	Height
896	436	656
Weight	Approx. 89 Kg	
Wall Thickness	10mm	

MARTIN MAC 250 BEAM

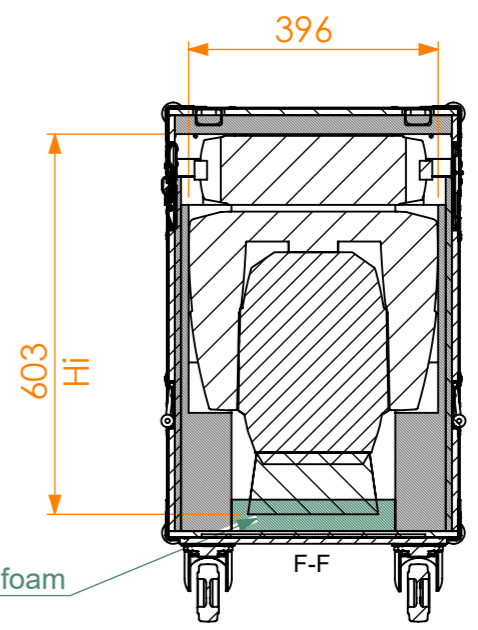
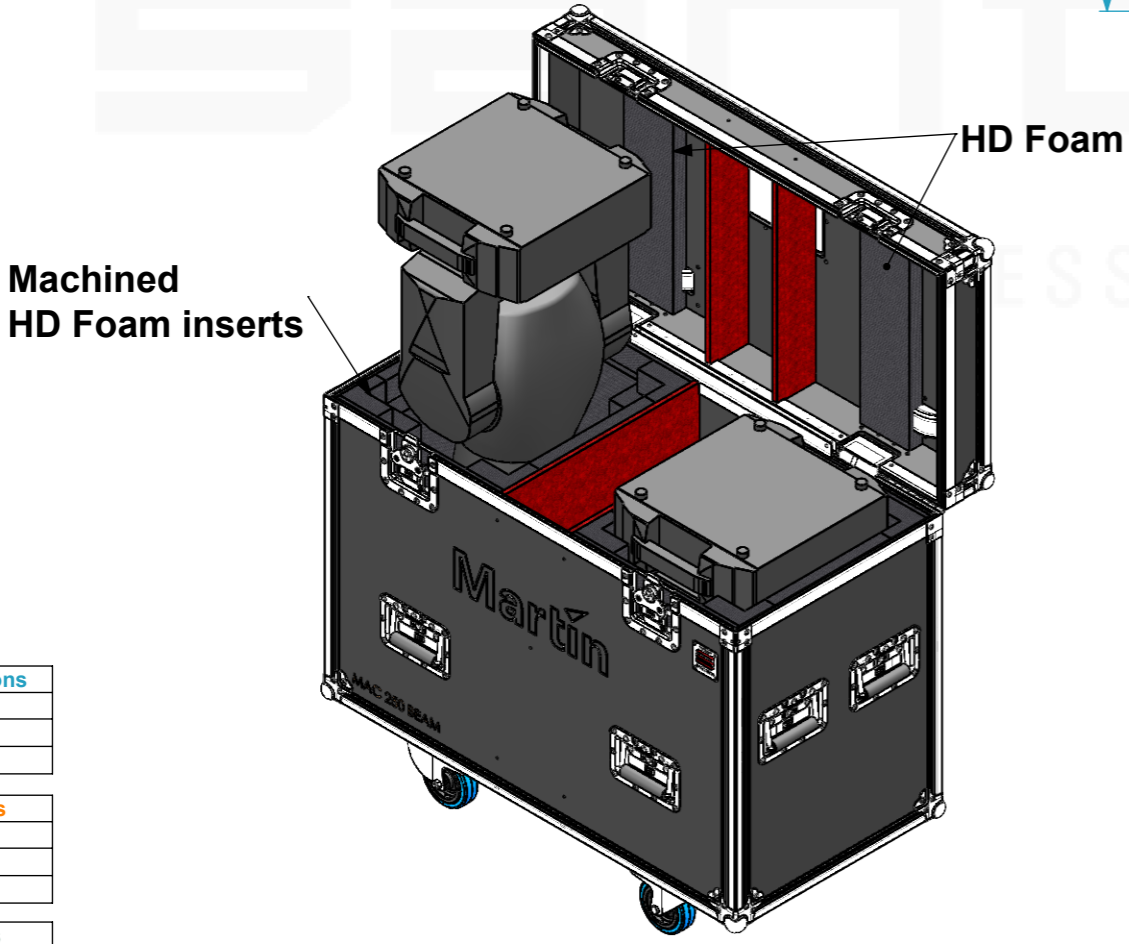
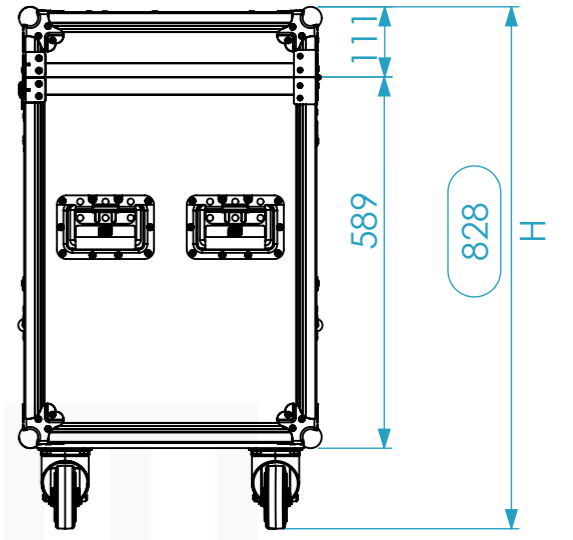
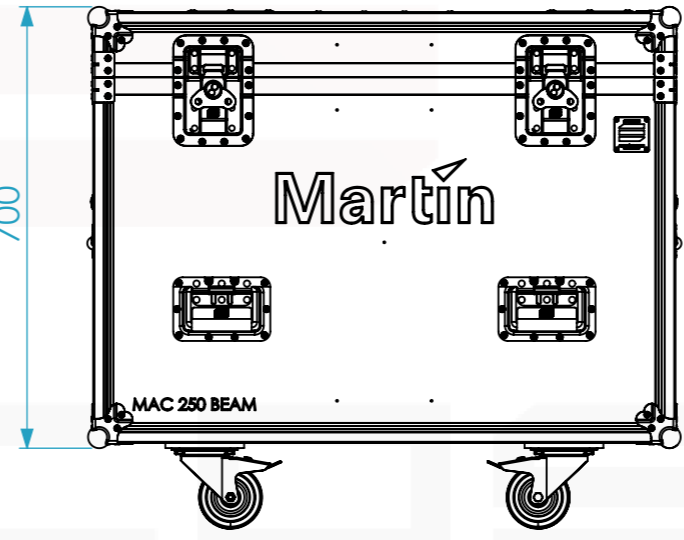
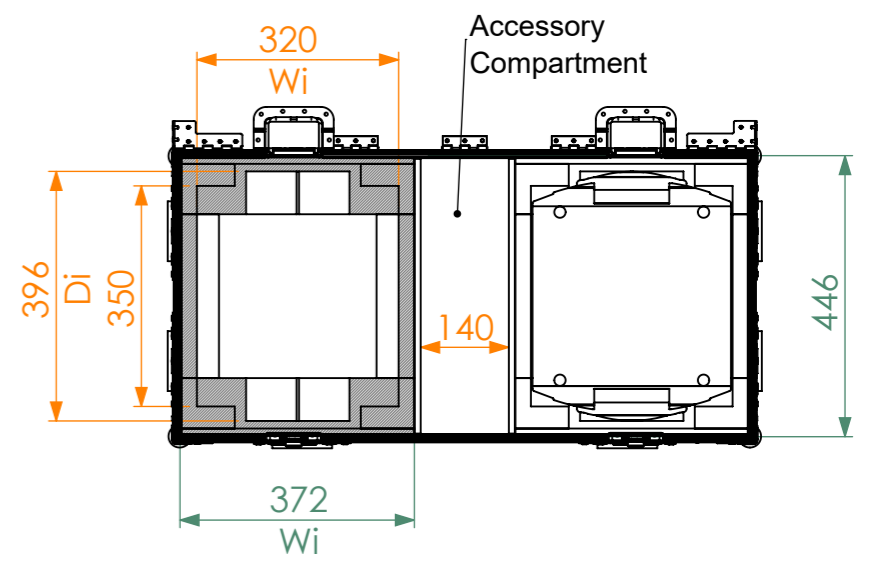
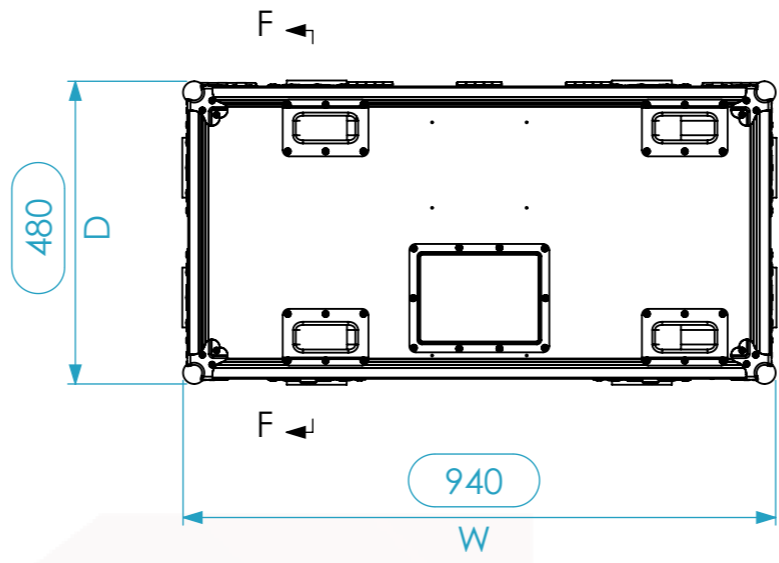
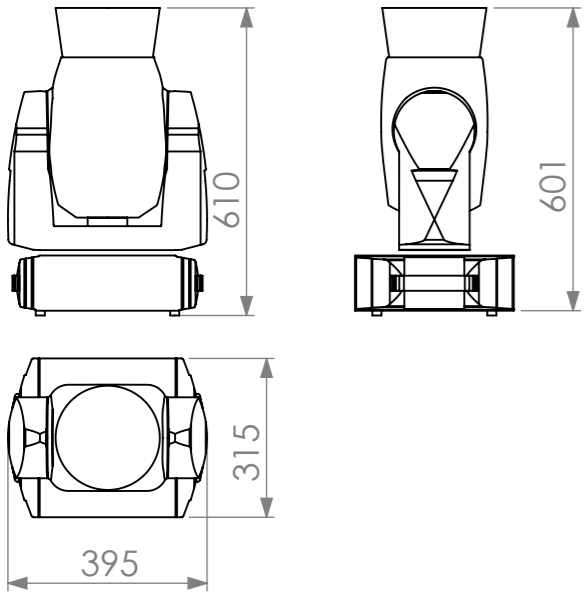

General External Dimensions	
W	Width
D	Depth
H	Height
Usable Inner Dimensions	
Wi	Inside Width
Di	Inside Depth
Hi	Inside Height
Wood Inner Dimensions	
WWi	Wood Inside Width
WDi	Wood Inside Depth
WHi	Wood Inside Height

This drawing must not be copied or disclosed without consent of the owner

Name	Date
Drawn by CatarinaDuque	11-02-2019
Reference	MHEAD.855
Scale	1:12
units in mm	general tolerance 0.8mm
DO NOT SCALE	
2X MARTIN MAC 250 BEAM + ACCESS.	



A3

