

REVISIONS				
ZONE	REV.	DESCRIPTION	DATE	APPROVED
-	-	Preliminary Drawing	26/08/2014	Daniel Lopes

Interior dimensions		
Width	Depth	Height
605	755	740
Weight	Approx. 43 Kg	
Wall Thickness		10mm

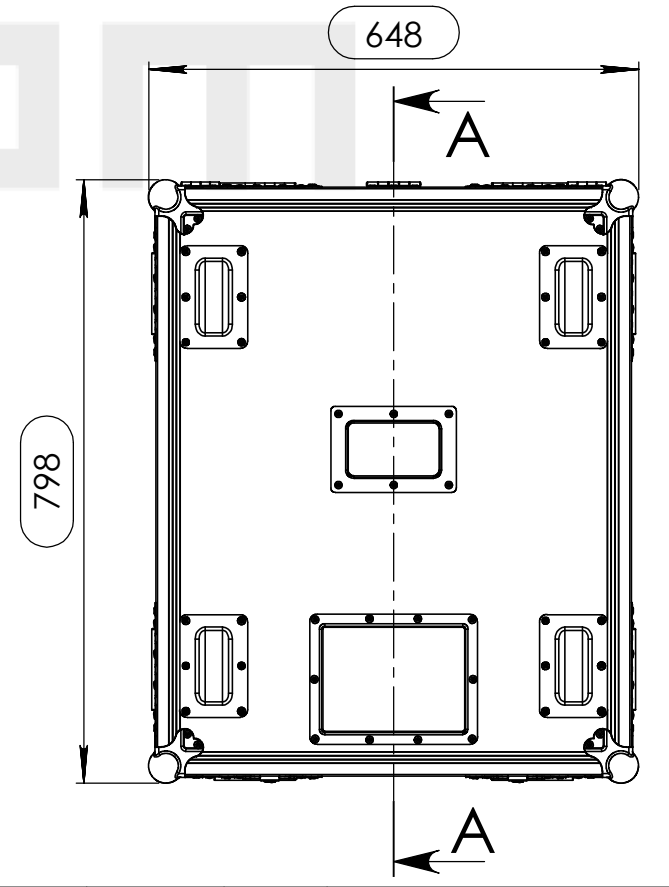
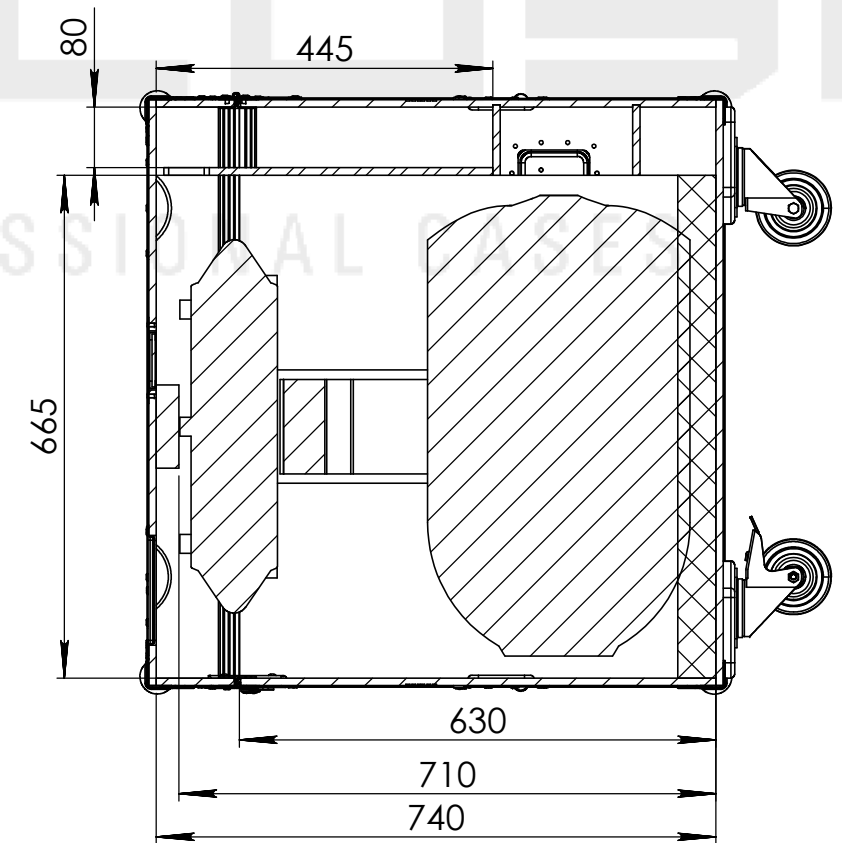
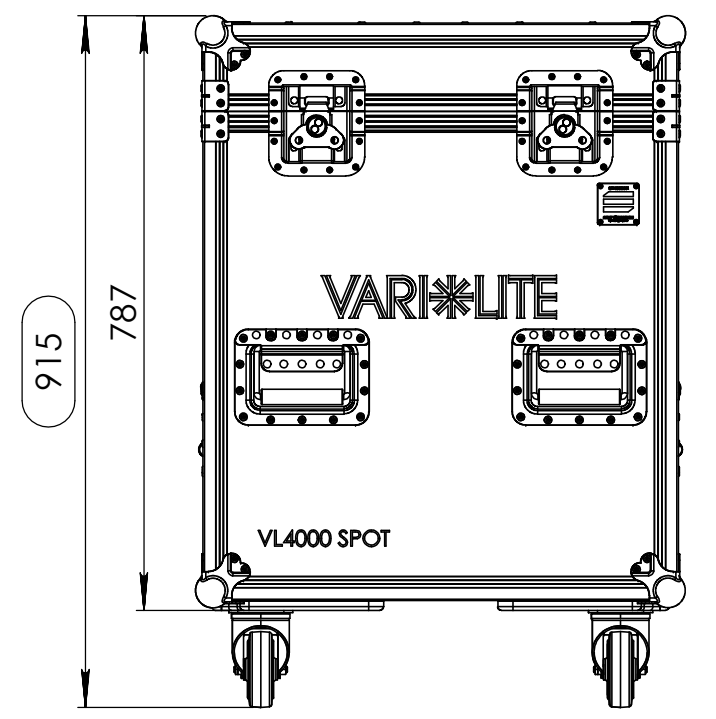
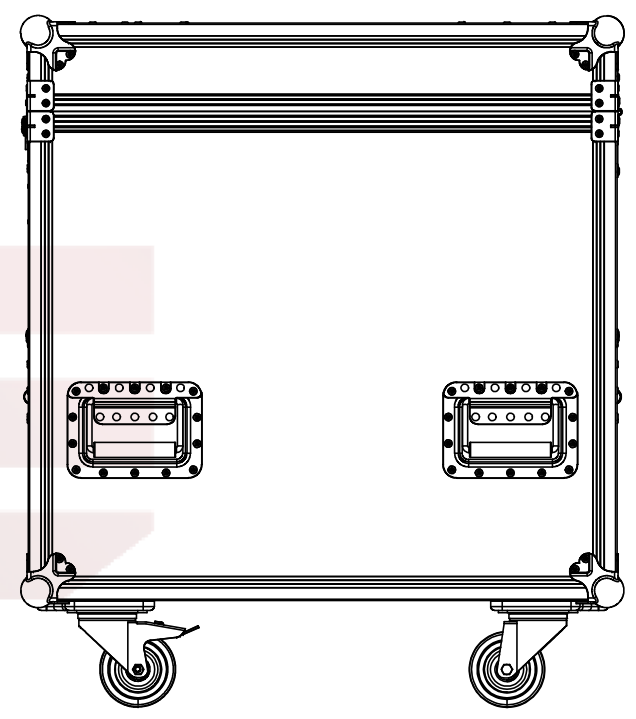
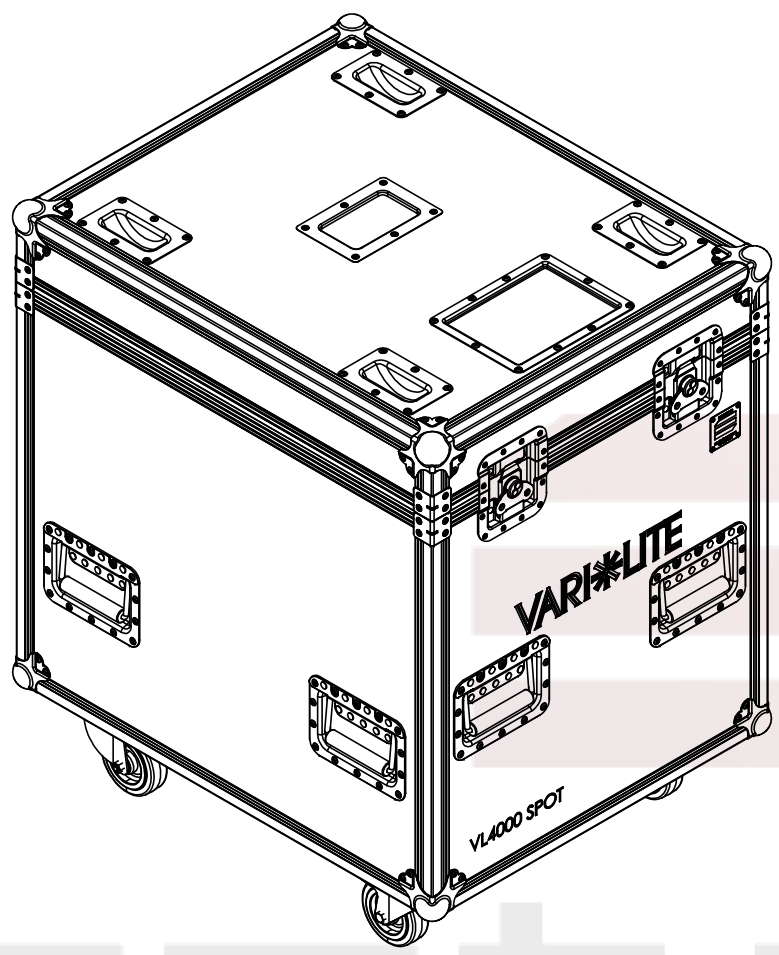
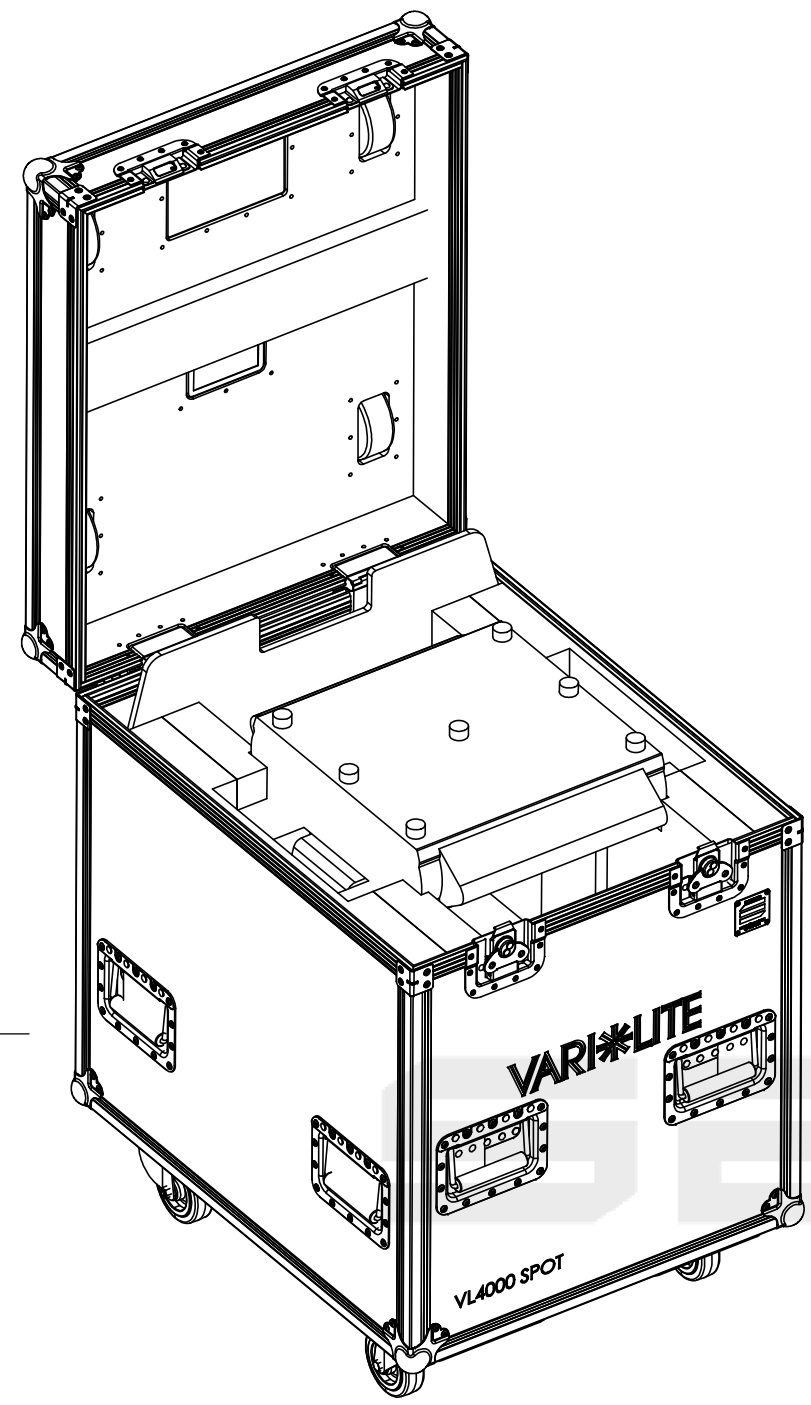

Hardware		
Qty	Ref.	Description
8	40403	Large corner bracket f. 35mm case angle
8	410429	Heavy Duty Ball Corner
8	34085	Large, heavy duty, recessed sprung handle
2	RODA.100T	Swivel castor Ø100mm with brake
2	RODA.100	Swivel castor Ø100 mm
2	270736	Short recessed lidstay cranked
2	172531	Large butterfly V3 with 'push-back' function
1	88001D	Dish for 88001 Tour Label
4	38083	Castor dish deep zinc plated
1	2602	Medium duty butt hinge z./p.
2	2601	Hinge small 1,3 mm Steel zinc plated
1	8795	Bar Code Scan Window

SECTION A-A

Drawn by	Name	Date
DanielLopes	DanielLopes	29-08-2014
Reference	MHEAD.806	
Scale	units in mm	general tolerance
1:10	DO NOT SCALE	±0.8mm
1st Angle projection	FC. VARI*LITE VL4000 RODAS	



This drawing must not be copied or disclosed without consent of the owner

A3