

### Interior dimensions

Width	Depth	Height
900	480	480
Weight	Approx. 38 Kg	
Wall Thickness	10mm	

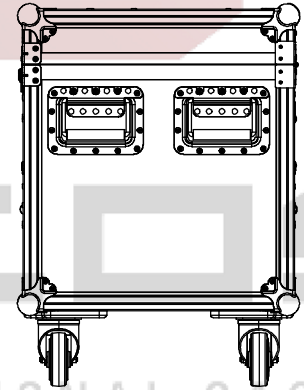

REVISIONS				
ZONE	REV.	DESCRIPTION	DATE	APPROVED
-	-	Final Drawing	13/01/2015	Telmo Santos

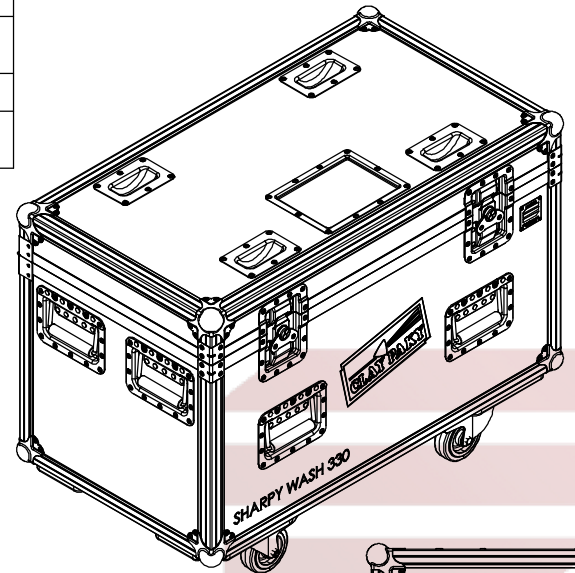
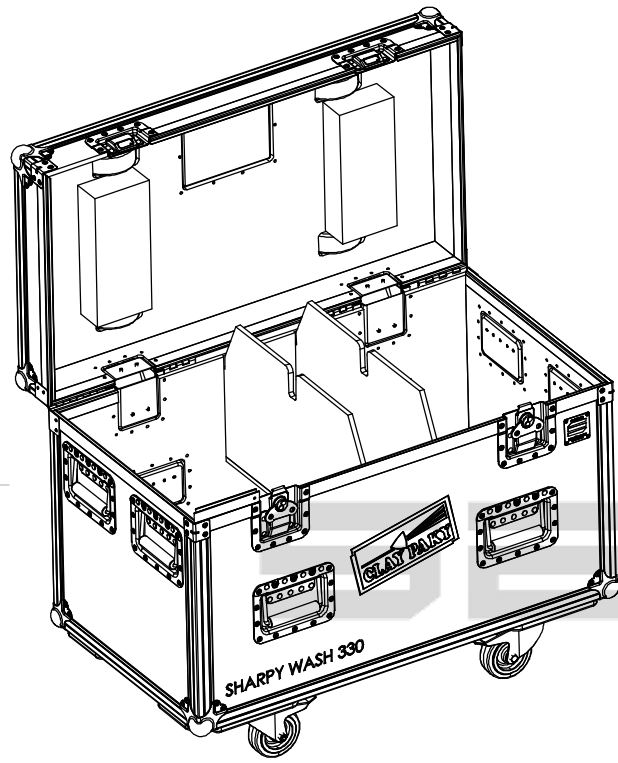
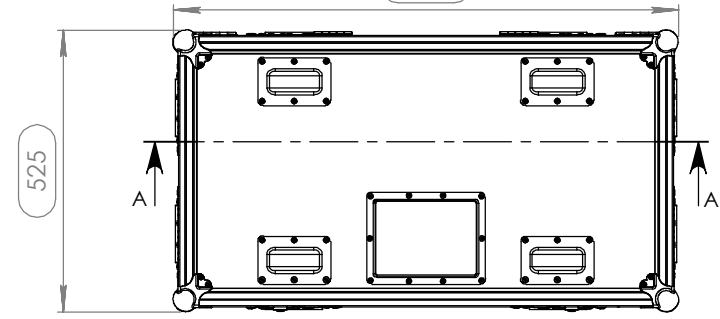
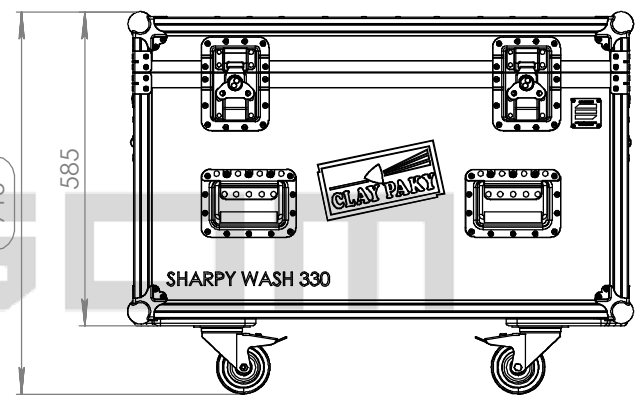
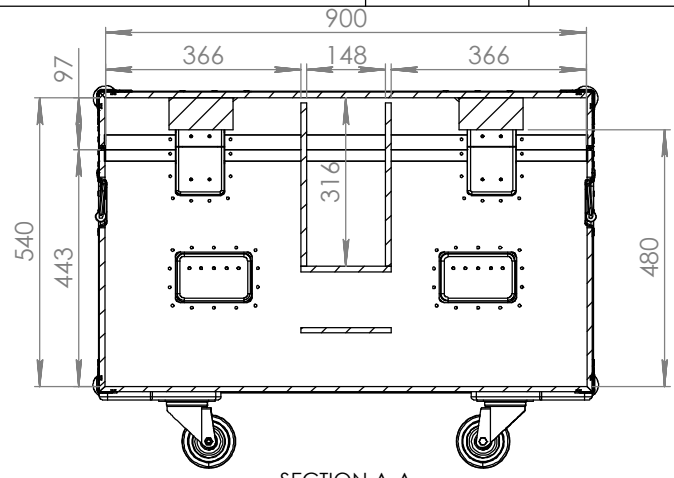

Hardware		
Qty	Ref.	Description
4	40403	Large corner bracket f. 35mm case angle
8	410429	Heavy Duty Ball Corner
2	172511COMP	Large AH butterfly with 'push-back' function in 14mm dish
1	88001D	Dish for 88001 Tour Label
2	270836	Large lidstay cranked / hinge
4	38083	Castor dish deep zinc plated
8	34085	Large, heavy duty, recessed sprung handle
2	DCR110	110MM hinge shot
2	RODA.100T	Swivel castor Ø100mm with brake
2	RODA.100	Swivel castor Ø100 mm
2	2602	Medium duty butt hinge z./p.

This drawing must not be copied or disclosed without consent of the owner

Drawn by	Name	Date
DanielLopes	DanielLopes	13/01/2015
Reference	MHEAD.2255	
Scale	units in mm	general tolerance
1:10	DO NOT SCALE	0.8mm
1st Angle projection	FC sem Foam Shell, 2 Clay Paky Sharpy WASH 330	

