

Interior dimensions		
Width	Depth	Height
940	510	655
Weight	Approx. 41 Kg	
Wall Thickness	10mm	

REVISIONS				
ZONE	REV.	DESCRIPTION	DATE	APPROVED
-	-	Final Drawing	16/08/2013	Telmo Santos
-	-	Updated Drawing	21/08/2013	Daniel Lopes

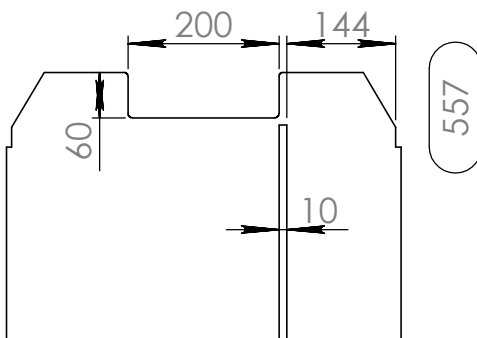
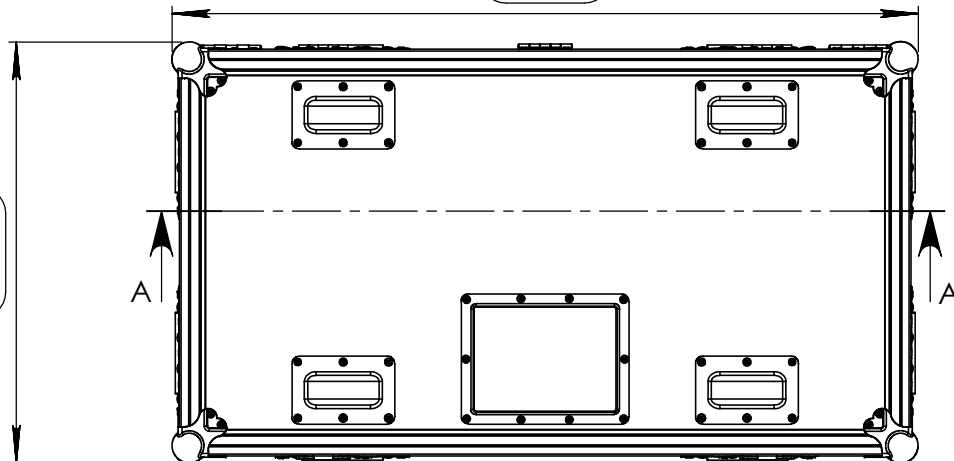
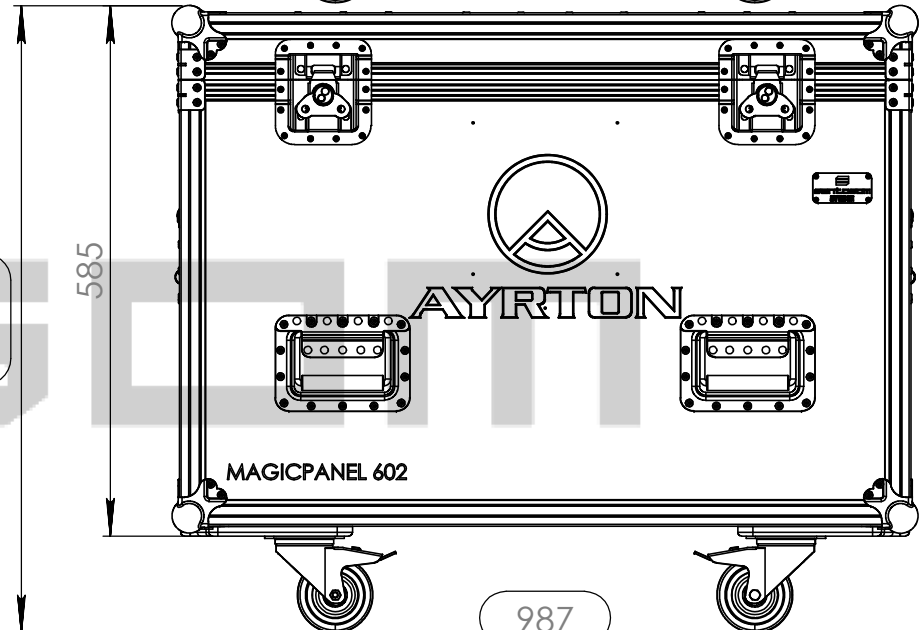
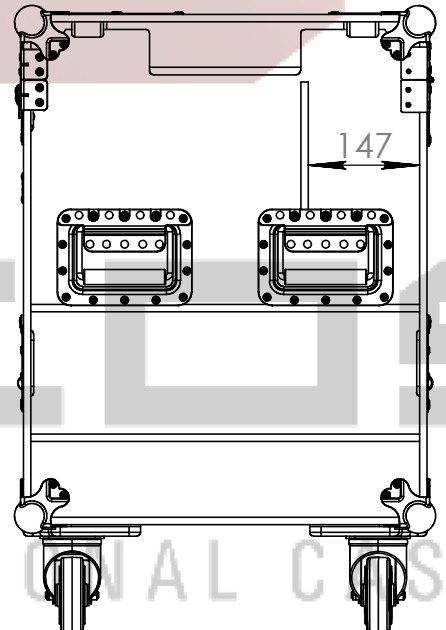
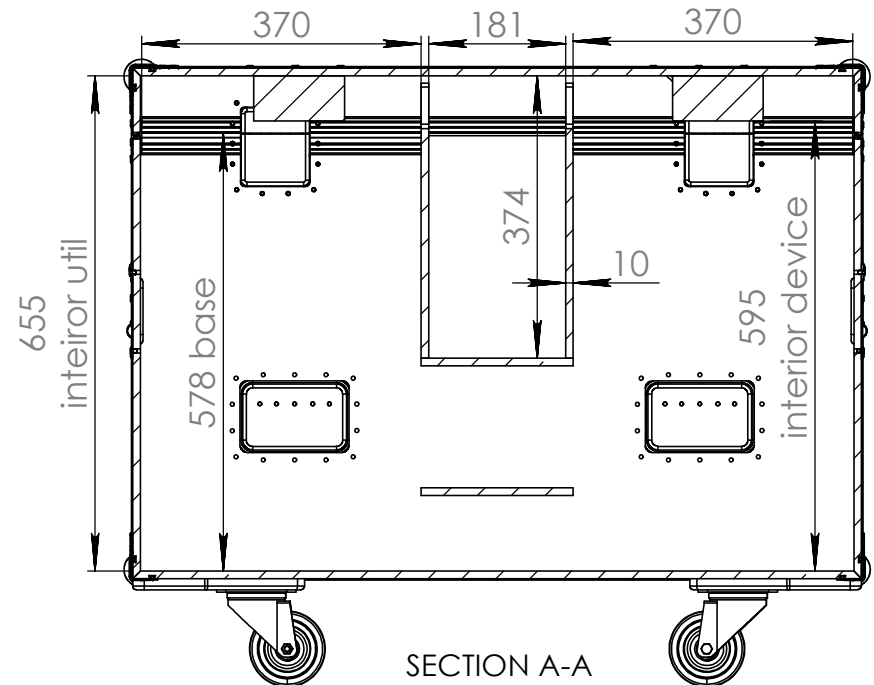
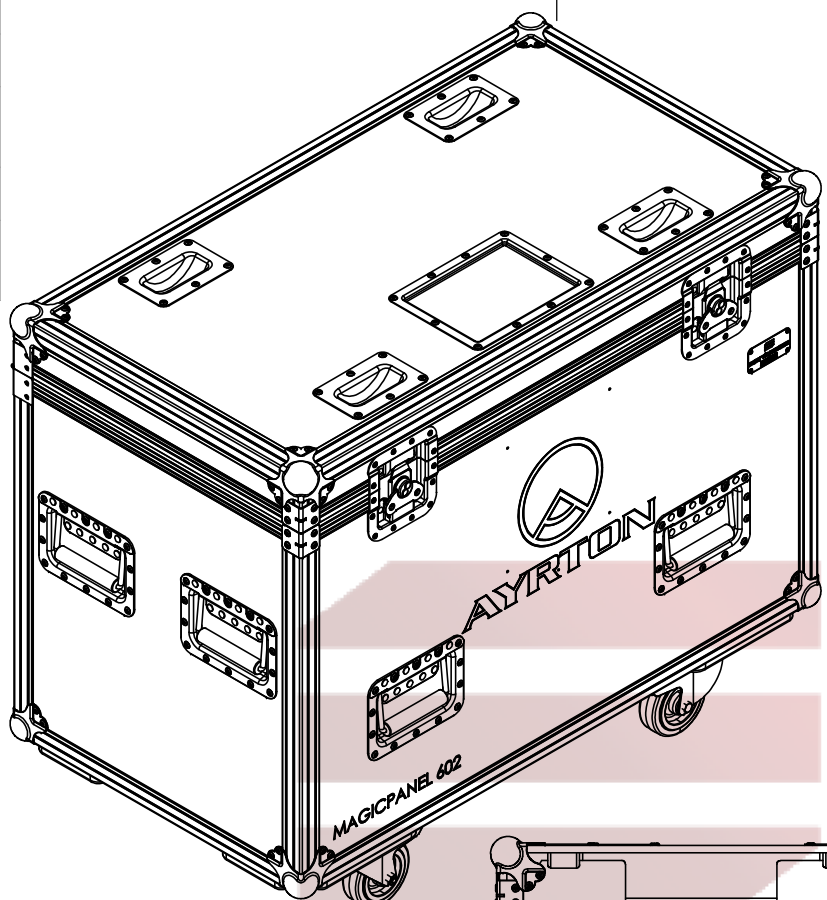
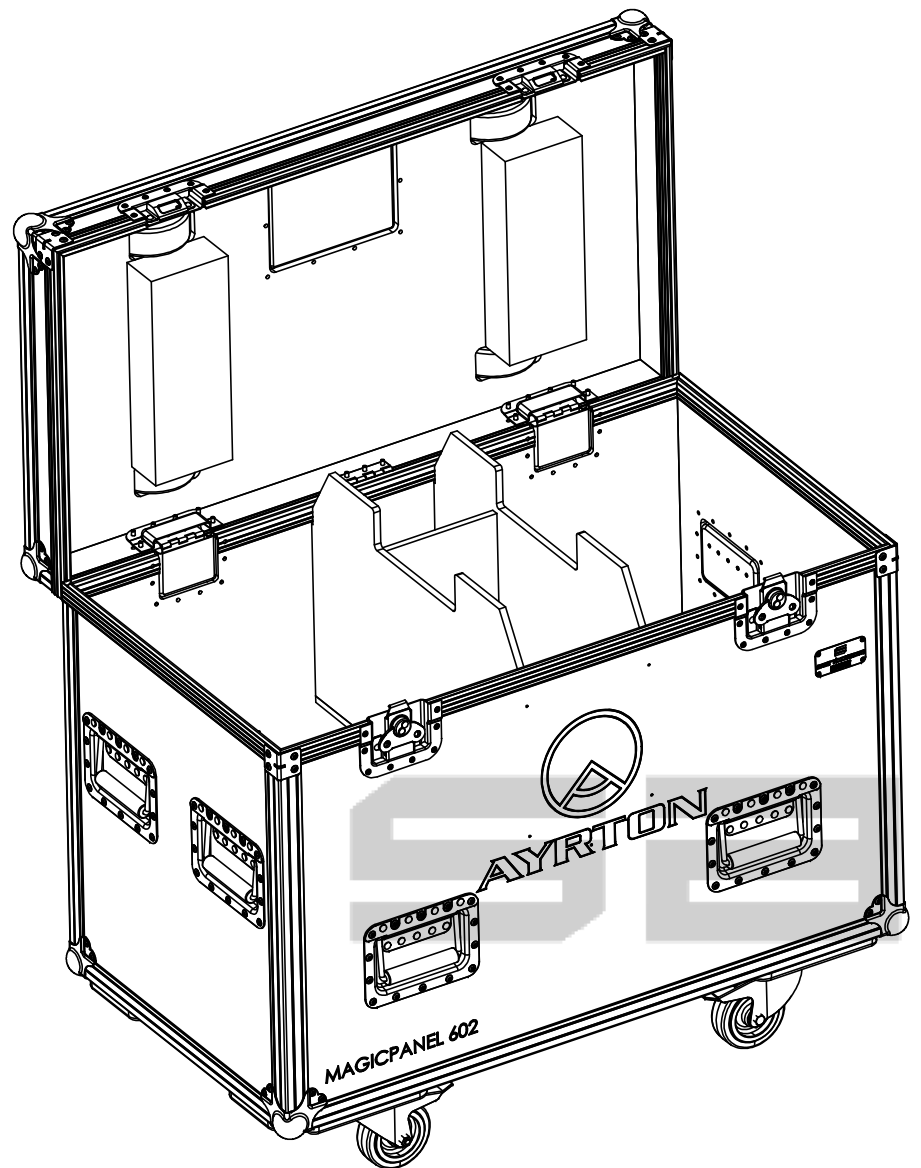

Hardware		
Qty	Ref.	Description
4	40403	Large corner bracket f. 35mm case angle
8	410429	Heavy Duty Ball Corner
1	88001D	Dish for 88001 Tour Label
4	38083	Castor dish deep zinc plated
8	34085	Large, heavy duty, recessed sprung handle
2	DCR110	110MM hinge shot
2	RODA.100T	Swivel castor Ø100 mm with brake
2	RODA.100	Swivel castor Ø100 mm
1	2602	Medium duty butt hinge z./p.
2	27073	Short recessed lidstay cranked
2	172531	Large butterfly V3 with 'push-back' function in 14mm dish

Drawn by	DanielLopes	Date	21-08-2013
Reference	MHEAD.219s		
Scale	1:10	units in mm	general tolerance 0.8mm
1st Angle projection	FC sem Foam Shell, 2 Clay Paky Sharpy		



This drawing must not be copied or disclosed without consent of the owner

A3