

Internal Dimensions		
Width	Depth	Height
896	396	550
Weight	Approx. 48 Kg	
Wall Thickness	10mm	

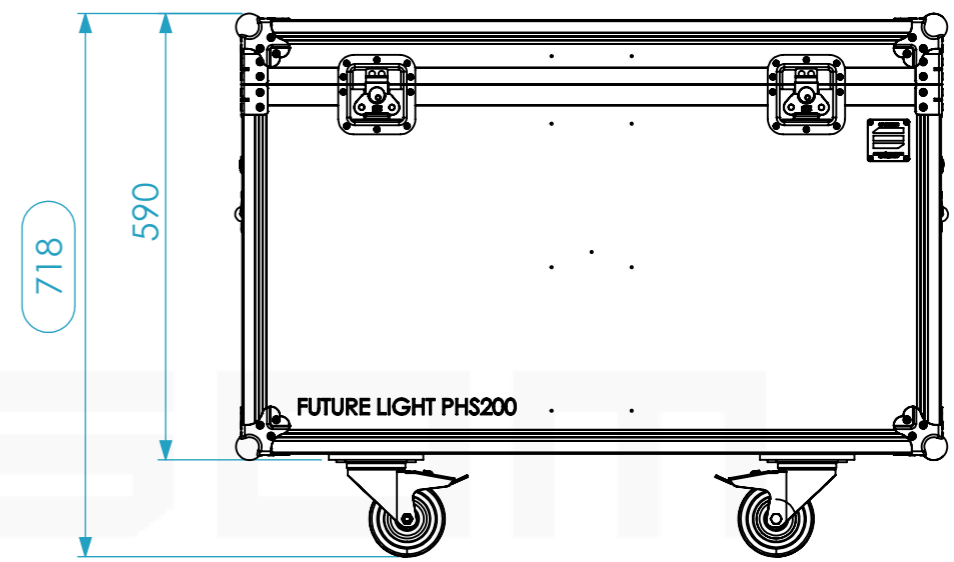

Hardware		
Qty	Ref.	Description
1	CHAPA.1000	Identification Plate
8	410429	Heavy Duty Ball Corner
2	R1.044	Whells Feet 360mm
2	RODA.100T	Swivel castor Ø100mm with brake
2	RODA.100	Swivel castor Ø100 mm
2	DCR110	Combination of Hinge and 2 Corner Braces
2	34082	Recessed Sprung Handle Medium
4	40403	Large corner bracket f. 35mm case angle
2	17290S	Key lockable medium Butterfly special
3	2524	HEAVY DUTY STRUT HINGE WITH BLACK PLATE

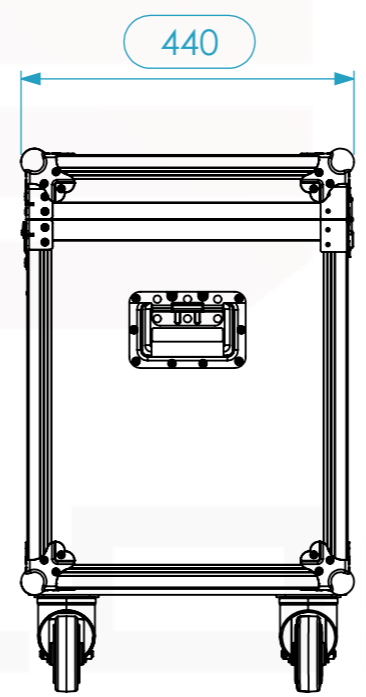
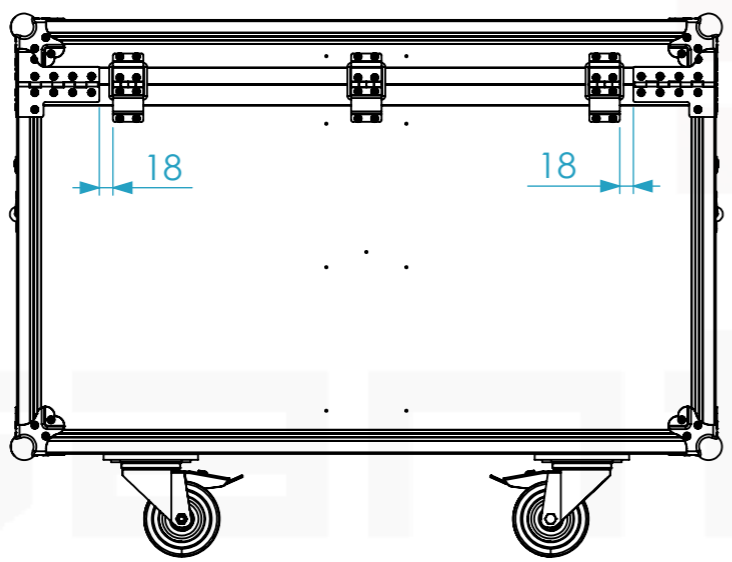
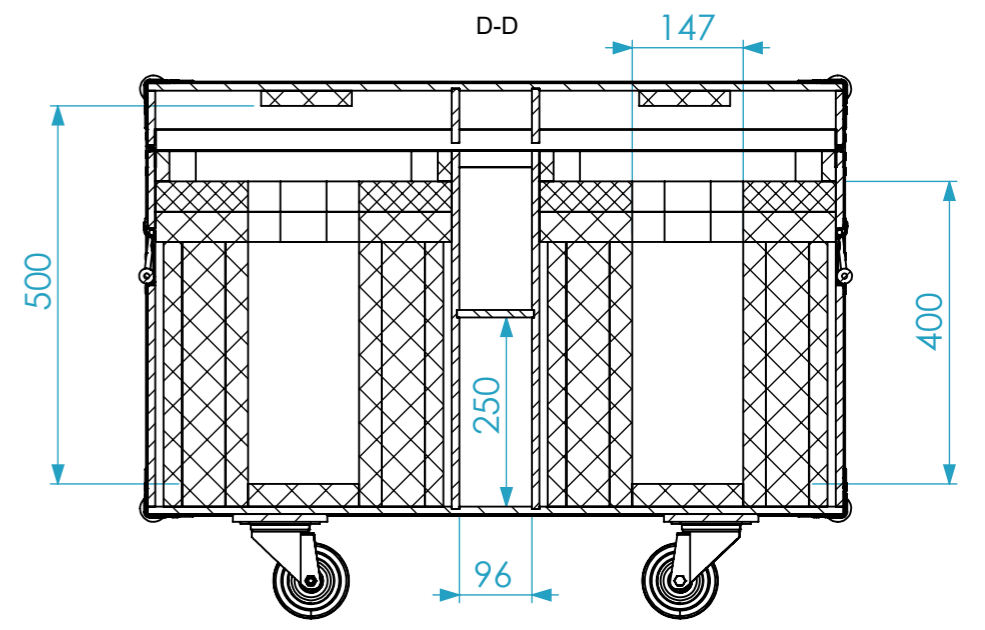
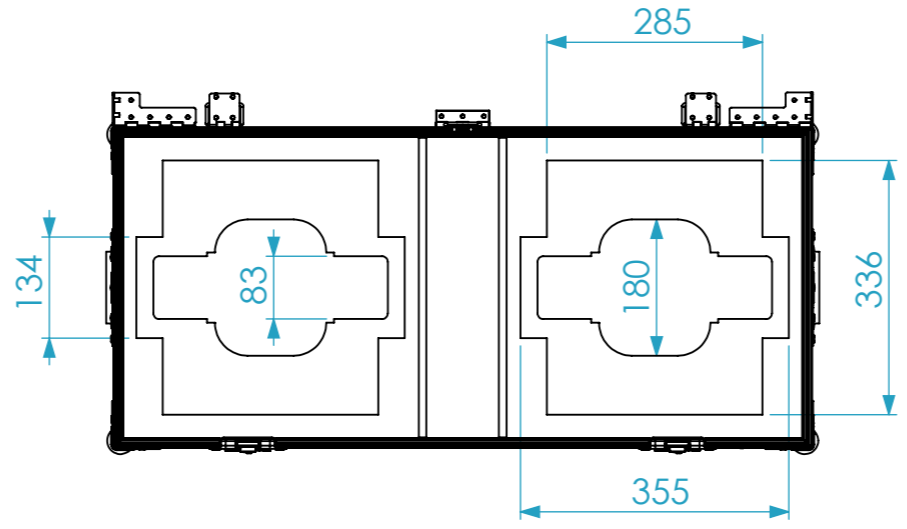
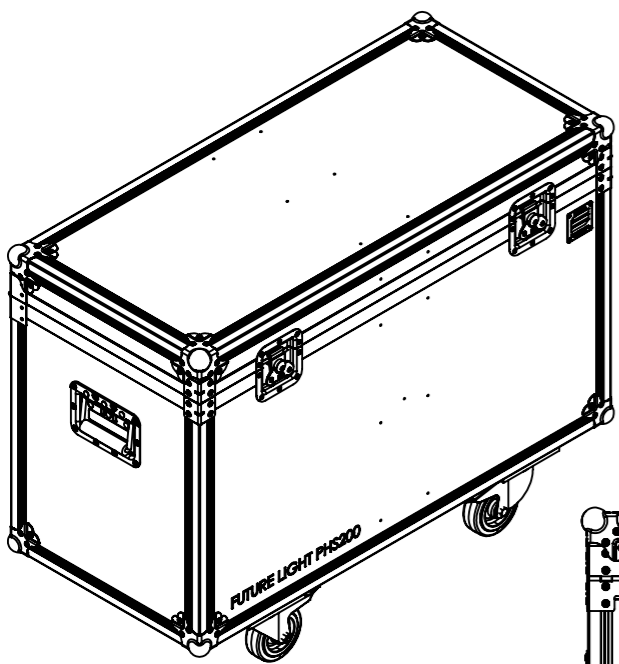
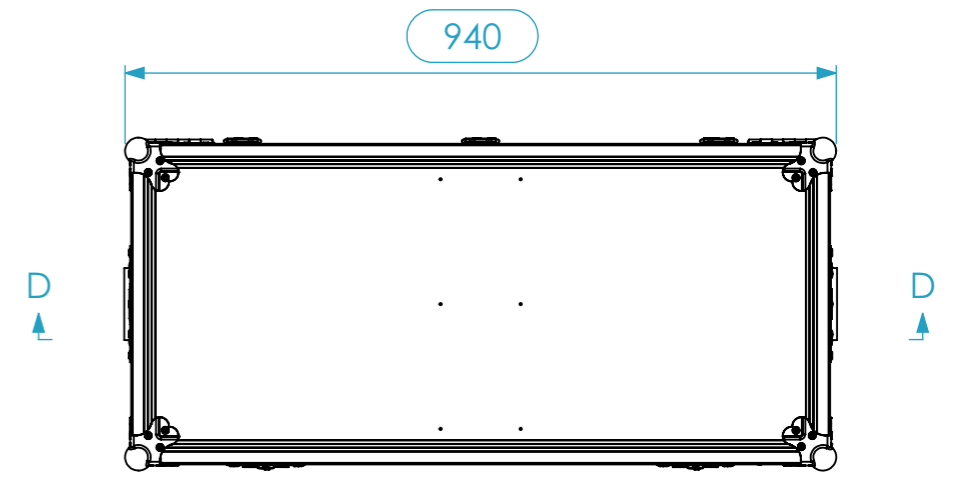
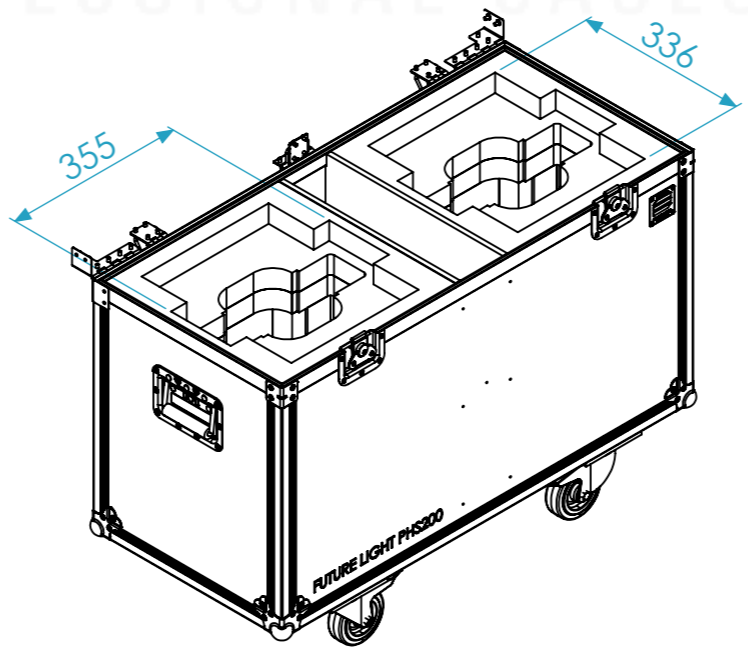

This drawing must not be copied or disclosed without consent of the owner

Drawn by	Name	Date
jorgepacheco	jorgepacheco	06/11/2017
Reference	MHEAD.201R8	
Scale	units in mm	general tolerance
1:10	DO NOT SCALE	0.8mm
1st Angle projection	FC. 2 Future Light PHS200, rodas 30XXLR + 3X NLB	

