

# Interior dimensions

Width	Depth	Height
620	400	95
Weight	Approx. 4 Kg	
Wall Thickness	7mm	

REVISIONS				
ZONE	REV.	DESCRIPTION	DATE	APPROVED
-	0	Final Drawing	29/01/2015	Carlos Rodrigues

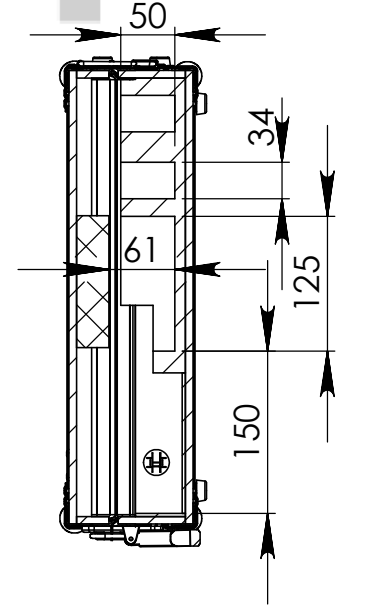
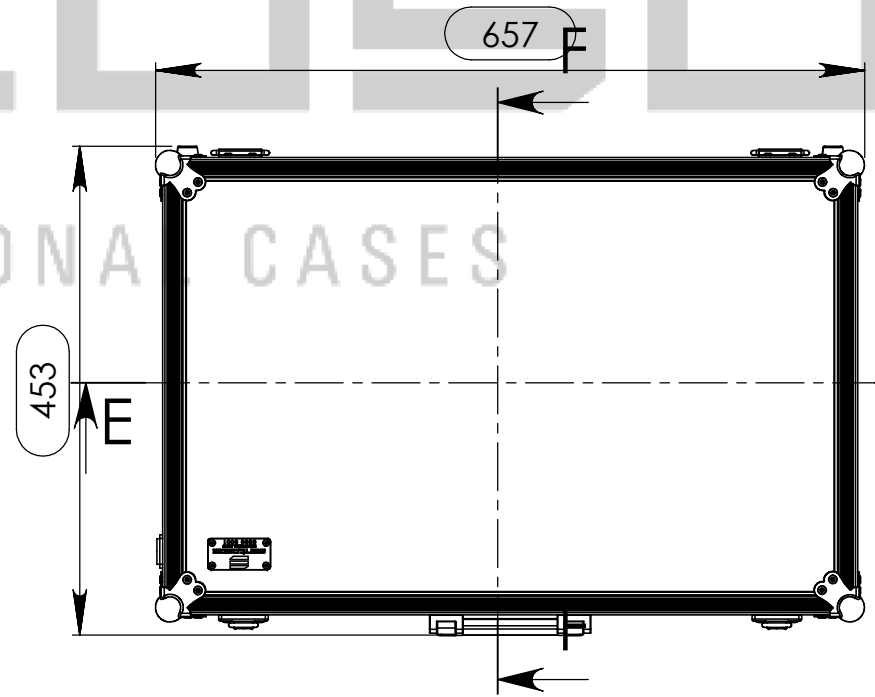
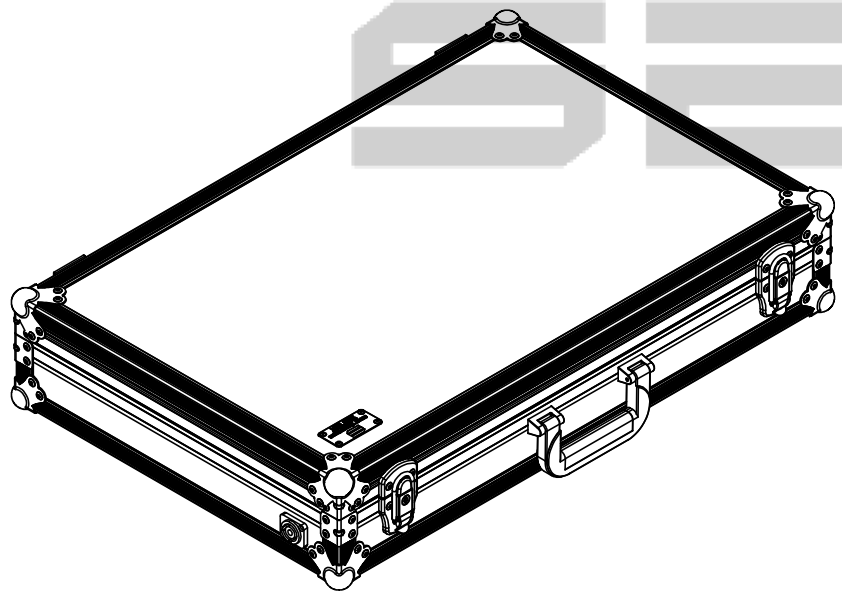
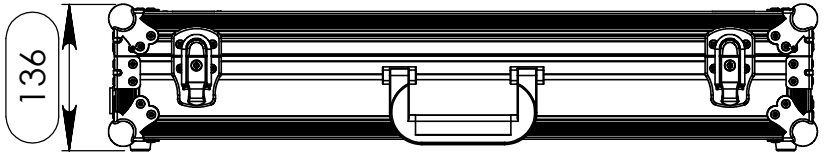
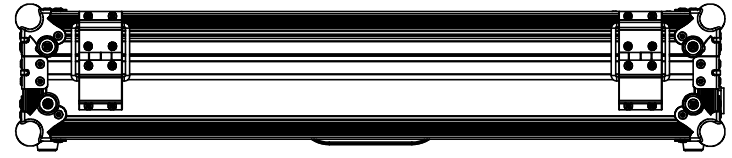
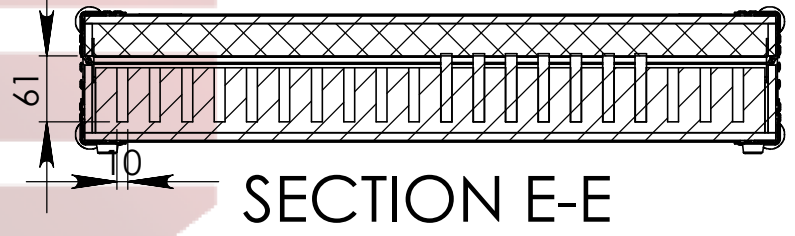
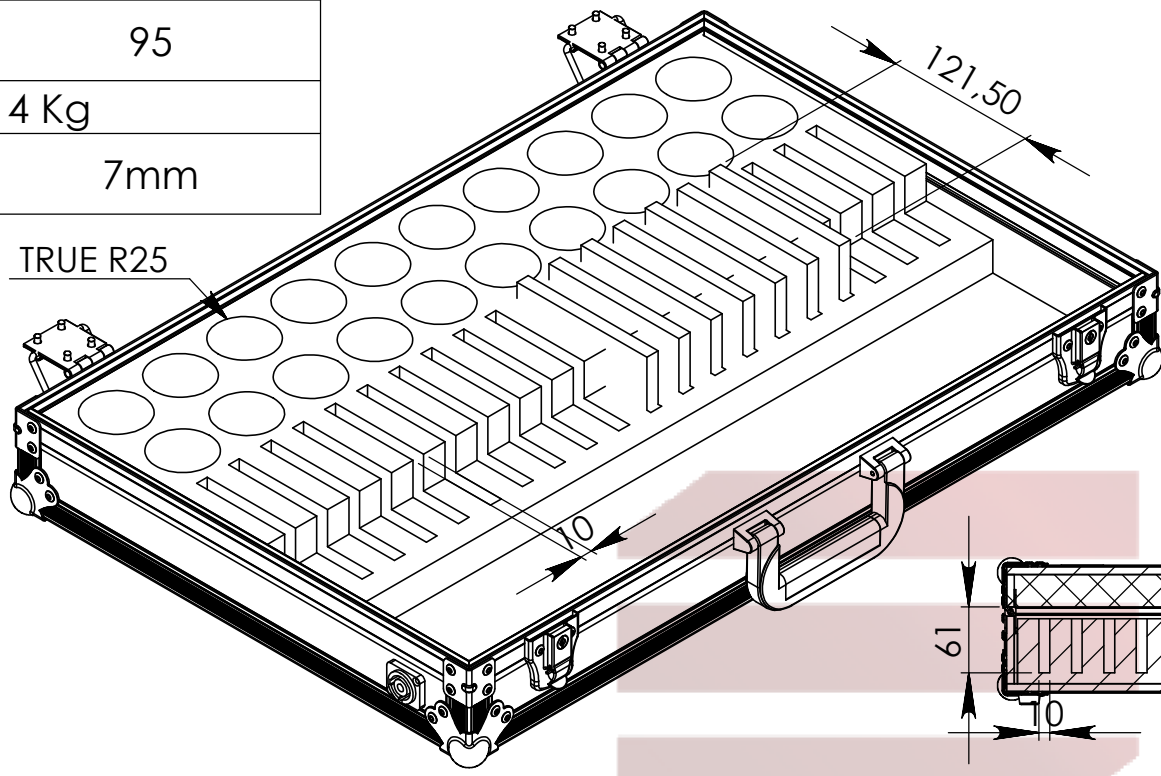

## Hardware

Qty	Ref.	Description
8	40407	Medium corner-brace zinc plated 1,0mm
8	C1345Z	Small ball corner - 3 leg - zinc plated
1	3430	Chrome plated plastic with soft black plastic insert
2	2524	Heavy Duty Strut Hinge, zinc plated
2	1903	Heavy drawbolt with lock chrome
8	4903	Rubber foot 20 x 9 mm, black
1	NAC3MPA	NAC3MPA - FICHA POWERCON

This drawing must not be copied or disclosed without consent of the owner

Drawn by	Name	Date
projects		29-01-2015
Reference	MC1.0600B	
Scale	units in mm	general tolerance
1:7	DO NOT SCALE	0,8mm
MULTICASE, 20X SAMSUNG GALAXY TREND 2		

