

Equipment	CHAMSYS MagicQ MQ250M Stadium Console	
Width	Depth	Height
680	416	159
Weight	Approx. 13 Kg	
Internal Dimensions		
Width	Depth	Height
654	382	146
Weight	Approx. 14.8 Kg	
Wall Thickness	7mm	

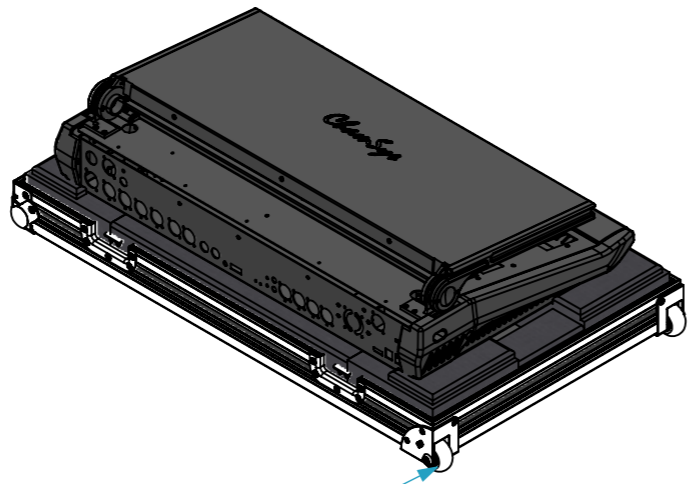

General External Dimensions	
W	Width
D	Depth
H	Height
Usable Inner Dimensions	
Wi	Inside Width
Di	Inside Depth
Hi	Inside Height

Name	Date
Drawn by paula.almeida	13/10/2023
Reference	M12BR.CHAMQ250
Scale	1:10
units in mm	general tolerance 0.8mm
DO NOT SCALE	
1st Angle projection	Flight case STD-2, CHAMSYS MagicQ MQ250M Stadium Console

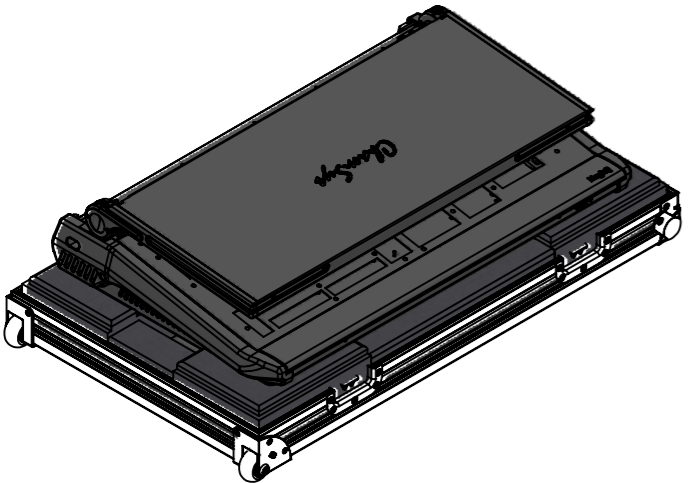
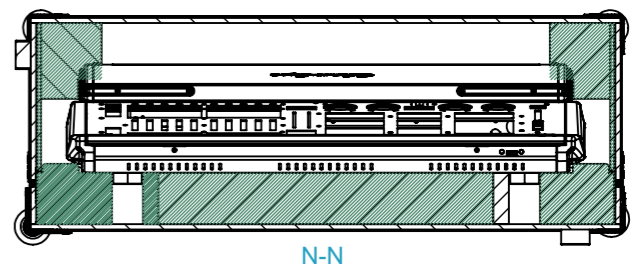
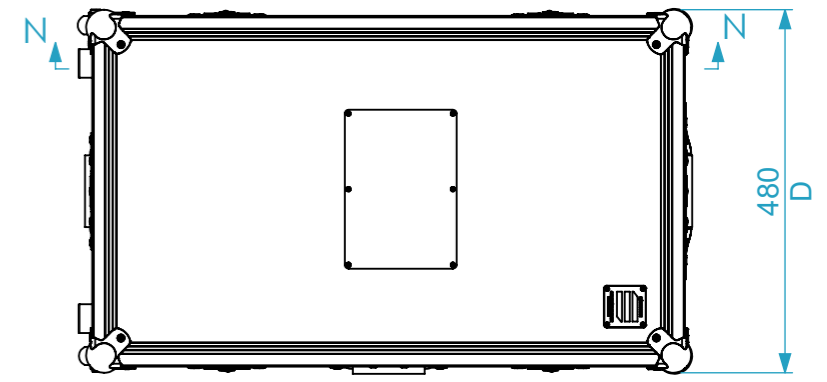
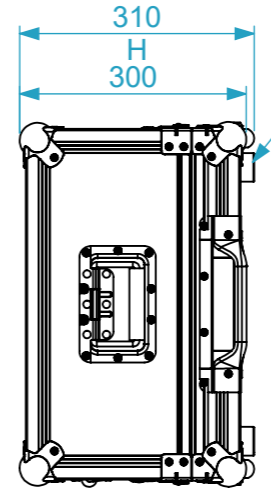
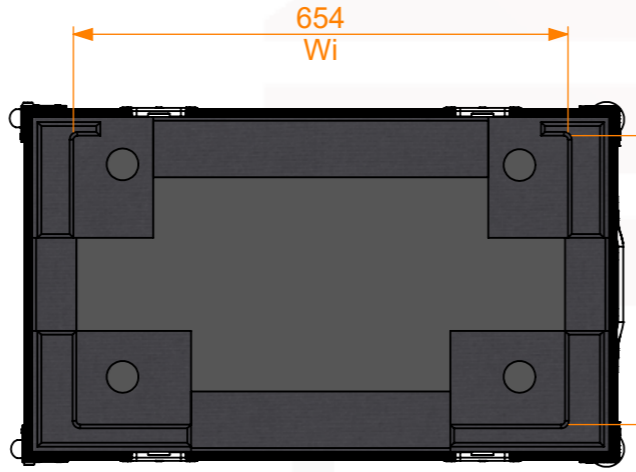
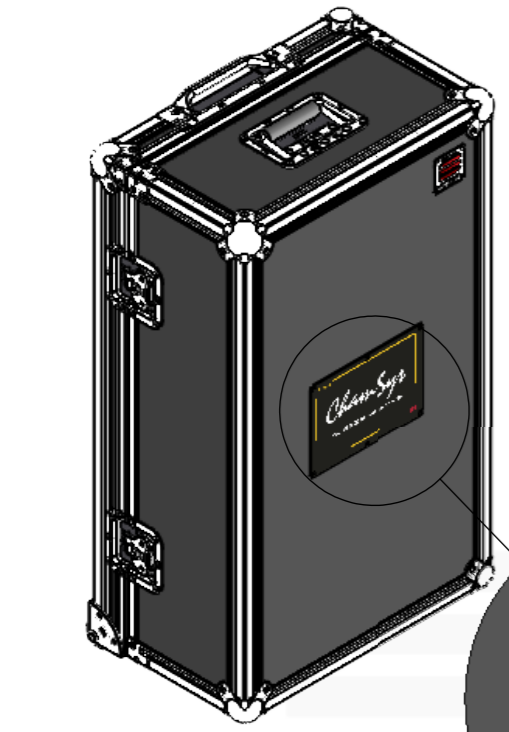
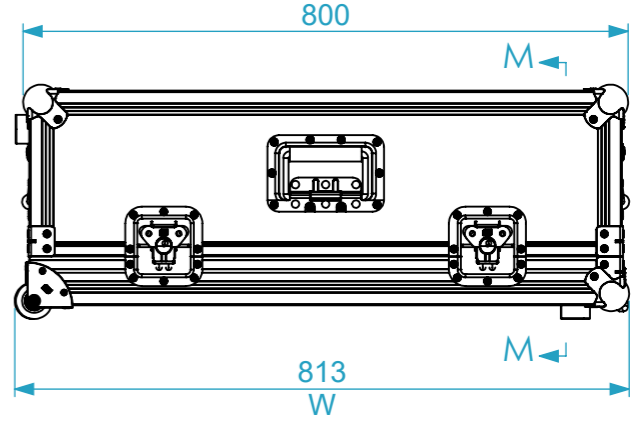
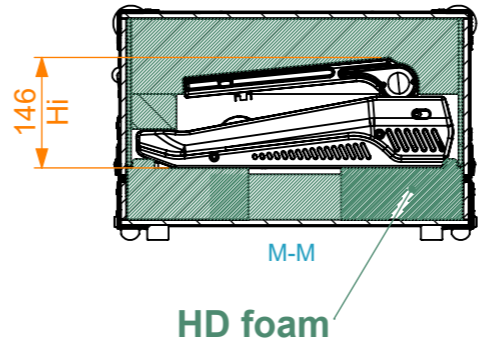

A3 This drawing must not be copied or disclosed without consent of the owner