

Equipment	grandMA3 Compact XT	
Width	Depth	Height
845	429	160
Internal Dimensions		
Width	Depth	Height
813	394,4	155
Weight	Approx. 11.8 Kg	
Wall Thickness	7mm	

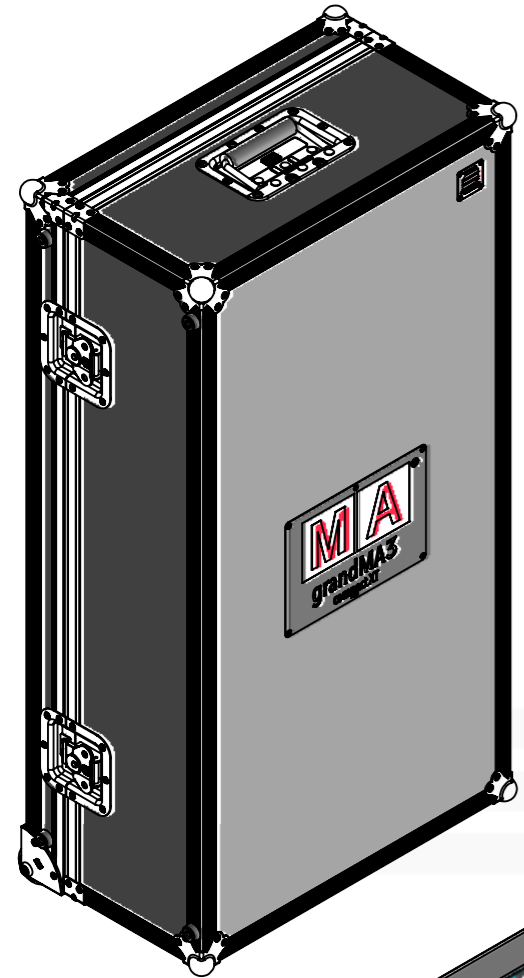

GrandMA3 compact XT
Net Weight: 20 kg

Keyboard Drawer with
touch pad
Ref: INF.KYB-N9Z14

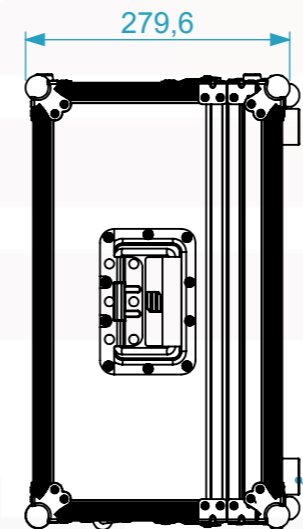
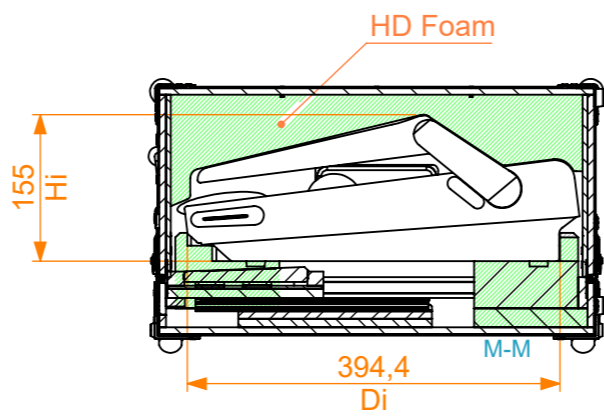

Ruber feet

Castor wheels

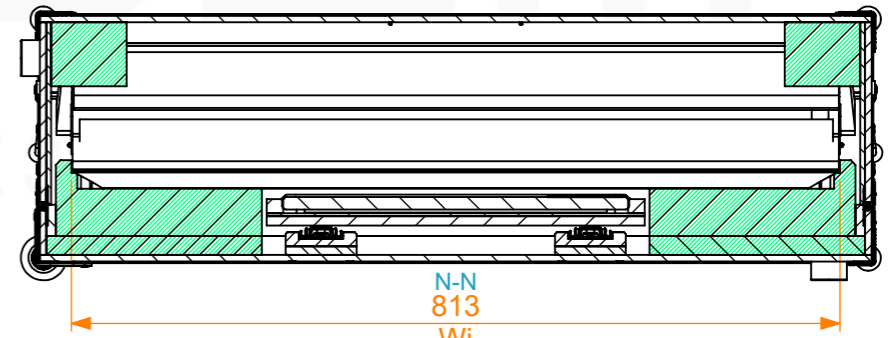
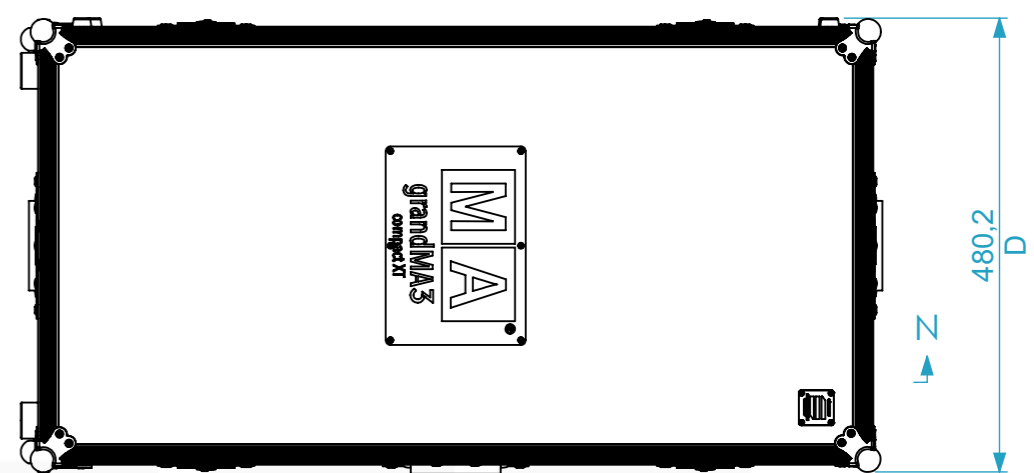
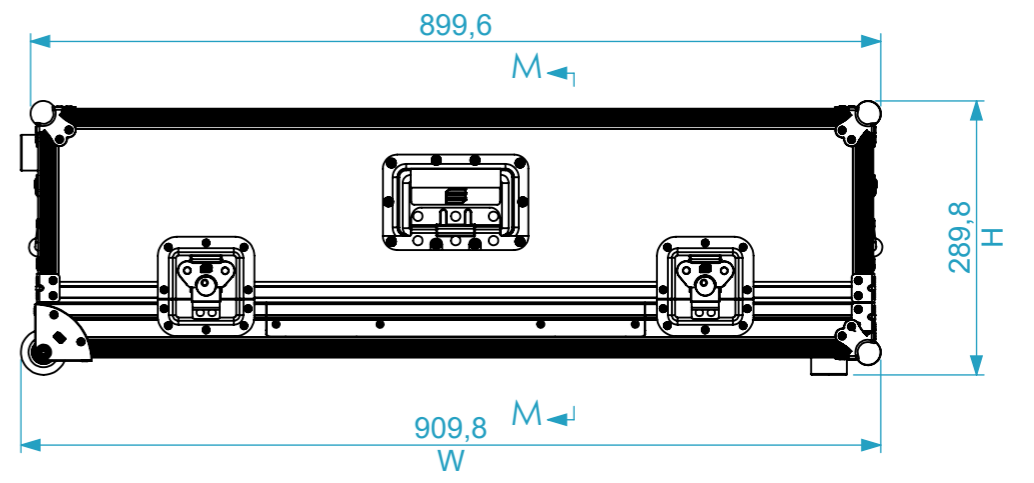

General External Dimensions	
W	Width
D	Depth
H	Height
Usable Inner Dimensions	
Wi	Inside Width
Di	Inside Depth
Hi	Inside Height
Wood Inner Dimensions	
WWi	Wood Inside Width
WDi	Wood Inside Depth
WHi	Wood Inside Height

Name	jose.couto	
Date	07/11/2022	
Reference	LMIXER.317A	
Scale	1:8	units in mm
	DO NOT SCALE	general tolerance 0.8mm
	Flight case LW, GrandMA3 Compact XT (W/ Drawer)	



This drawing must not be copied or disclosed without consent of the owner



A3