

### Interior dimensions

Width	Depth	Height
390	330	127
Weight	Approx. 7 Kg	
Wall Thickness		7mm

REVISIONS				
ZONE	REV.	DESCRIPTION	DATE	APPROVED
	0	Final Drawing	09/11/2015	Carlos Rodrigues

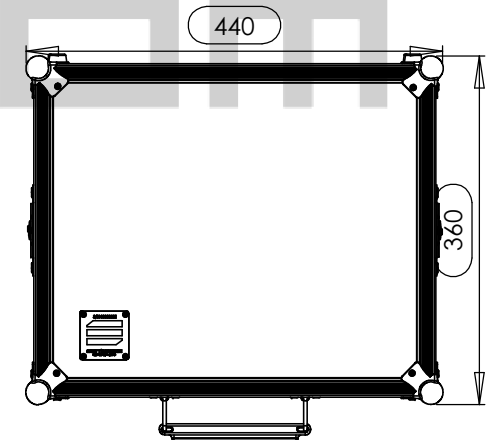
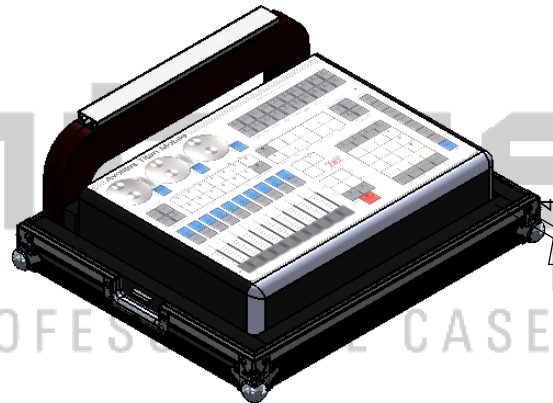
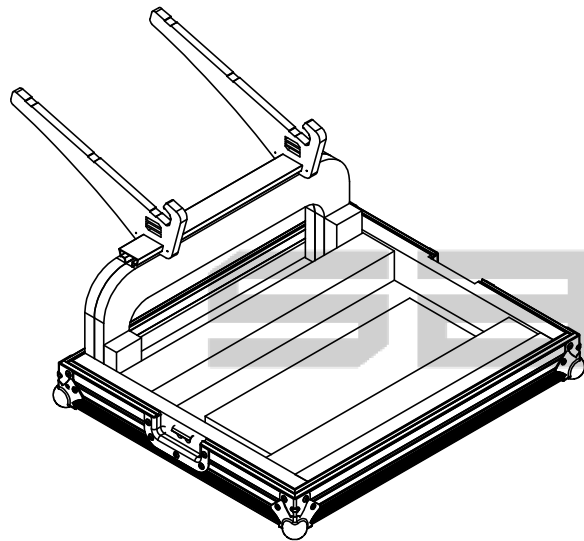
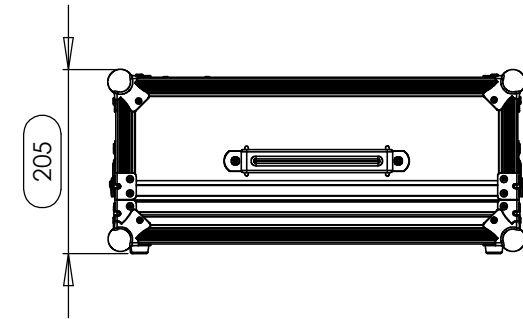
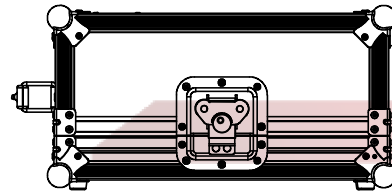

Hardware		
Qty	Ref.	Description
8	4113	
5	40407	Medium corner-brace zinc plated 1,0mm
3	40407	Medium corner-brace zinc plated 1,0mm
8	4903	Rubber foot 20 x 9 mm, black
1	CHAPA.1000	Identification Plate
2	17290S	Key lockable medium Butterfly special
1	3417	Leather Case Handle
2	SUPORTE.100 7	

This drawing must not be copied or disclosed without consent of the owner

Drawn by	Name	Date
projects		09/11/2015
Reference	LMIXER.206A	
Scale	1:6	
UNITS	mm	general tolerance 0.8mm
DO NOT SCALE		
1st Angle projection	MIXER AVOLITES TITAN MOBILE + PORTATIL	

