

Exterior dimensions

Width	Depth	Height
1202	670	750
Weight	Approx. 65 Kg	
Wall Thickness	10mm	

REVISIONS				
ZONE	REV.	DESCRIPTION	DATE	APPROVED
-	-	Final Drawing	17/12/2013	Daniel Lopes

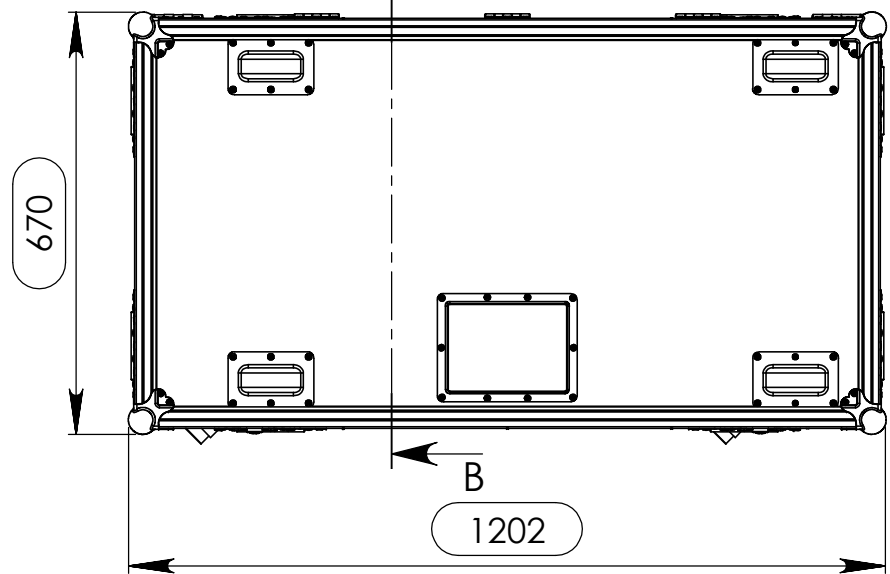
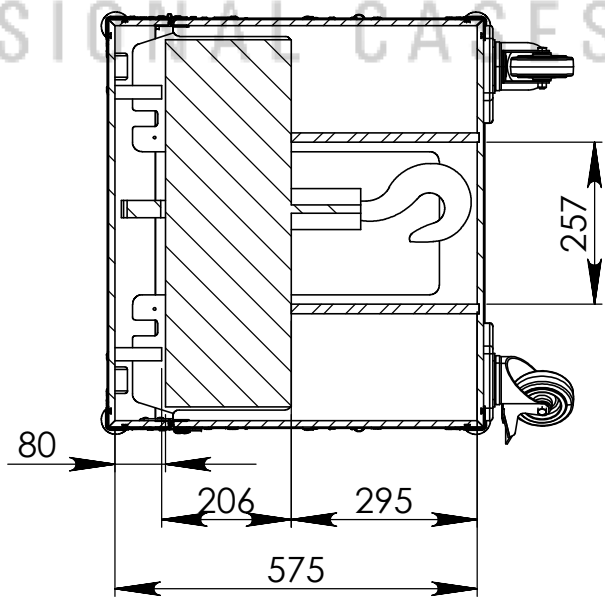
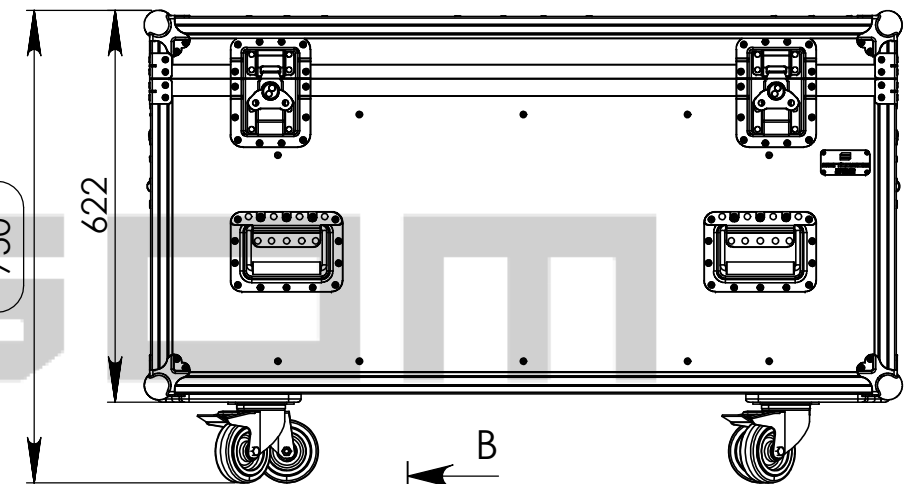
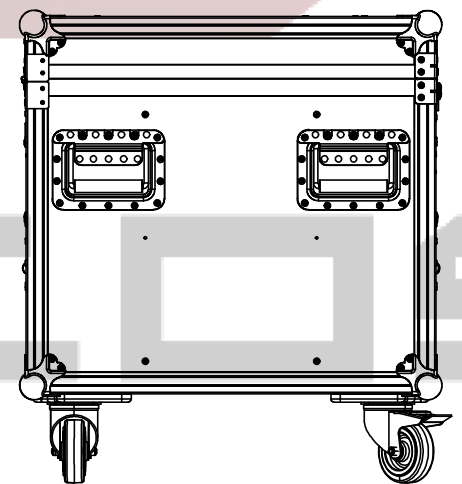
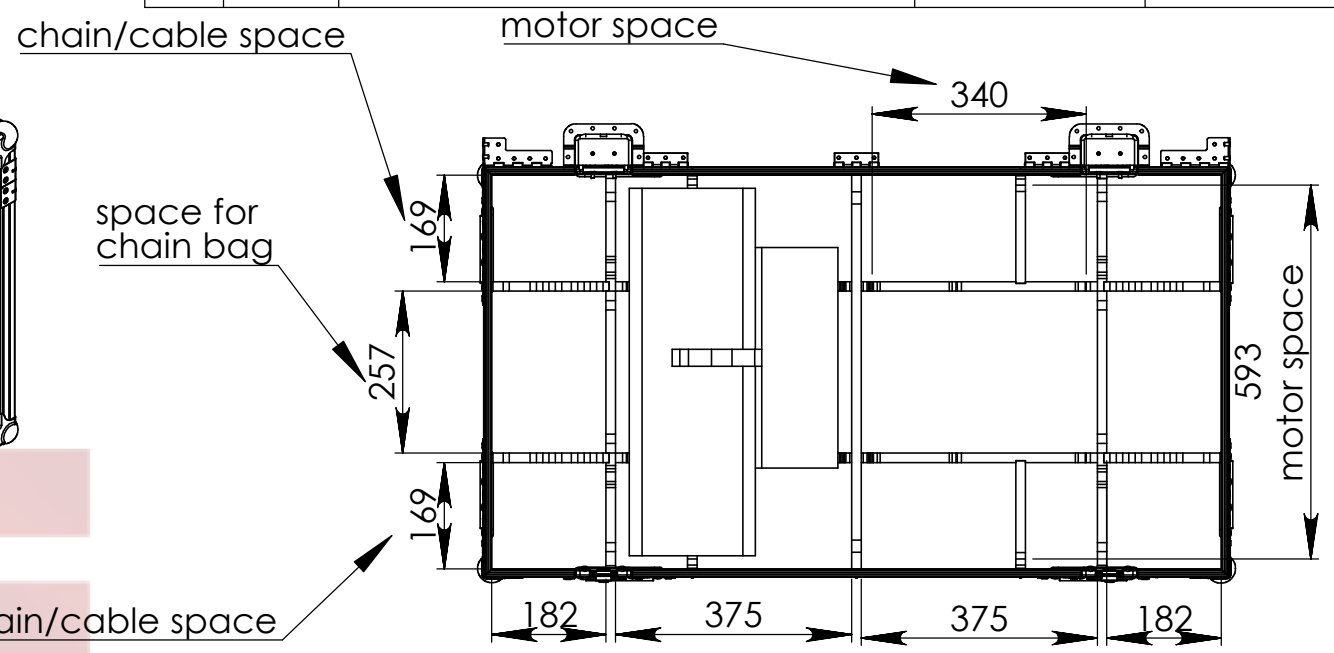
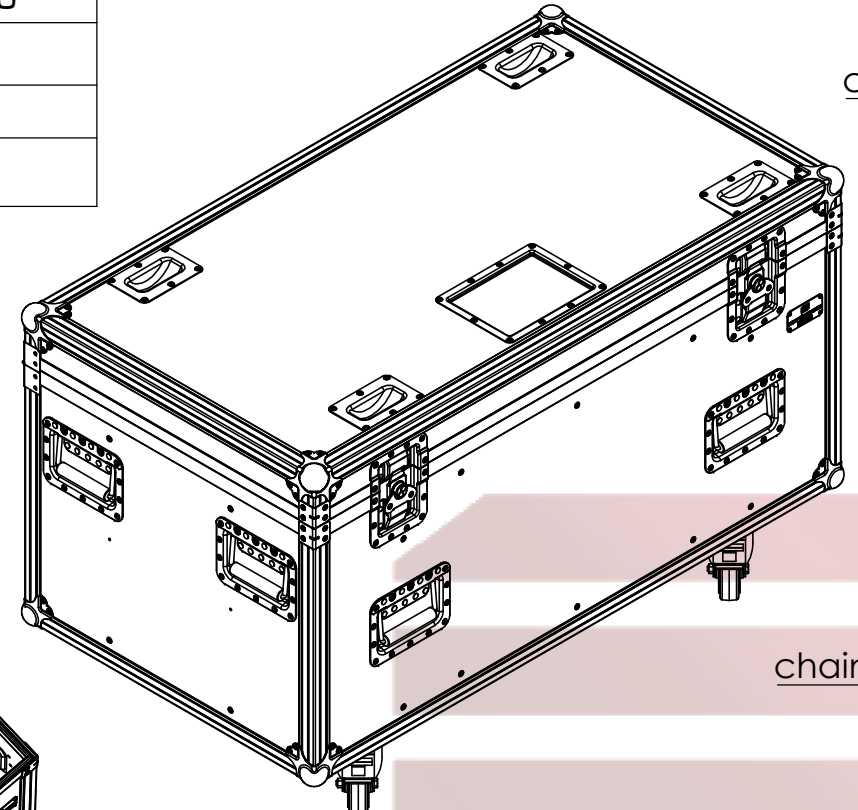
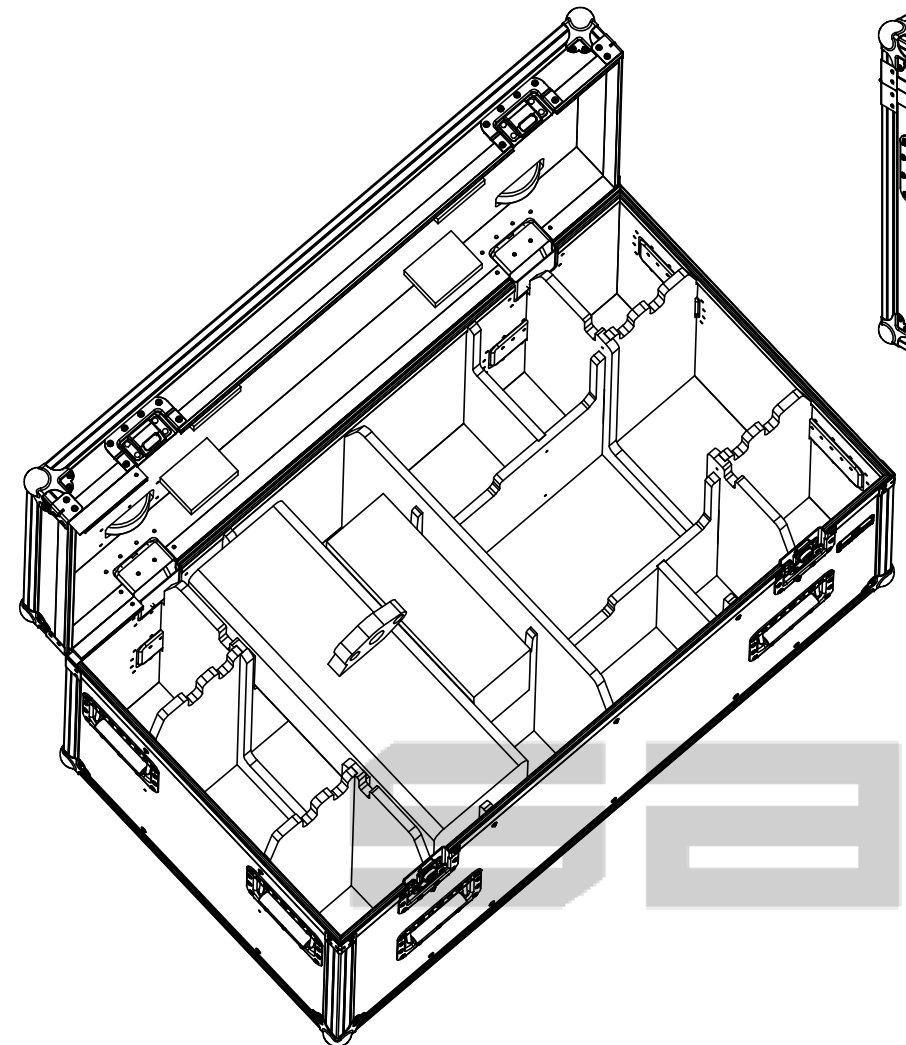

Hardware		
Qty	Ref.	Description
8	410429	Heavy Duty Ball Corner
4	40403	Large corner bracket f. 35mm case angle
8	34085	Large, heavy duty, recessed sprung handle
2	172511COMP	Large AH butterfly with 'push-back' function in 14mm dish
2	270836	Large lidstay cranked / hinge
1	88001D	Dish for 88001 Tour Label
4	38083	Castor dish deep zinc plated
2	DCR110	110MM hinge shot
1	RODA.100T	Swivel castor Ø100mm with brake
1	RODA.100T	Swivel castor Ø100mm with brake
2	RODA.100	Swivel castor Ø100 mm
3	2602	Medium duty butt hinge z./p.

SECTION B-B

This drawing must not be copied or disclosed without consent of the owner

Drawn by	Name	Date
DanielLopes	DanielLopes	17-12-2013
Reference	LIFT.L10	
Scale	units in mm	general tolerance
1:12	DO NOT SCALE	0.8mm
1st Angle projection	FC. 2X MOTORES 1 TON CLIMBING DMK4. RODAS	

