

Equipment	ChainMaster D8+ Ultra 250 kg	
Width	Depth	Height
309	178	98
FC Weight	Approx. 39 Kg	
Wall Thickness	10mm	

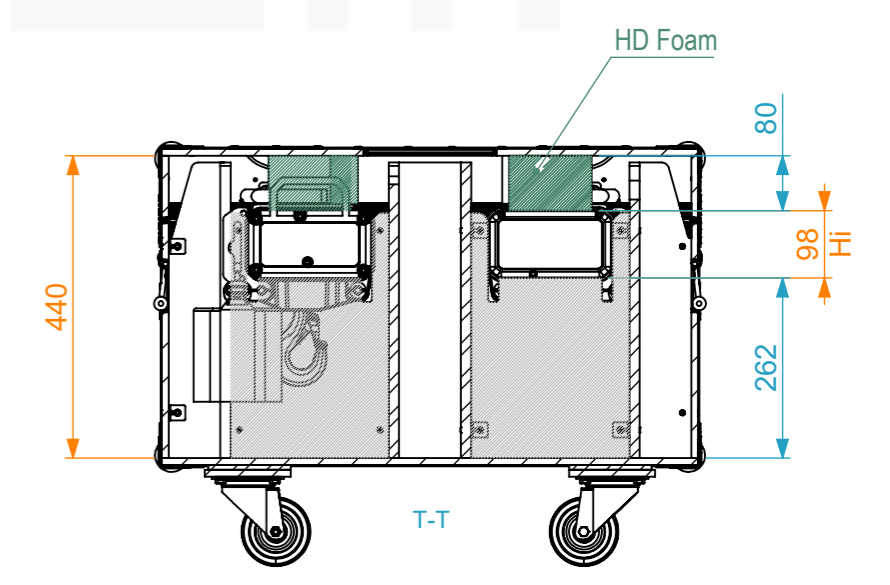
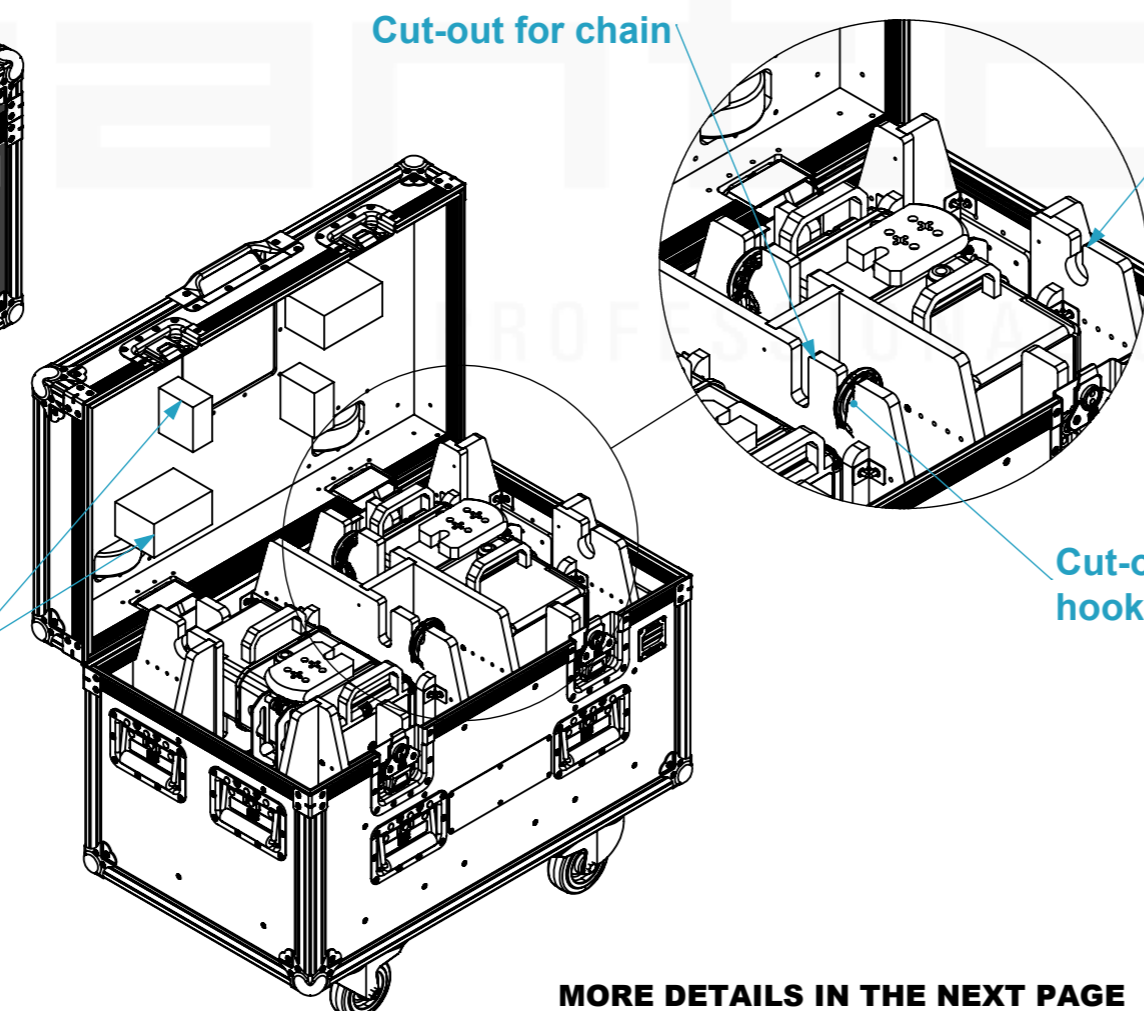
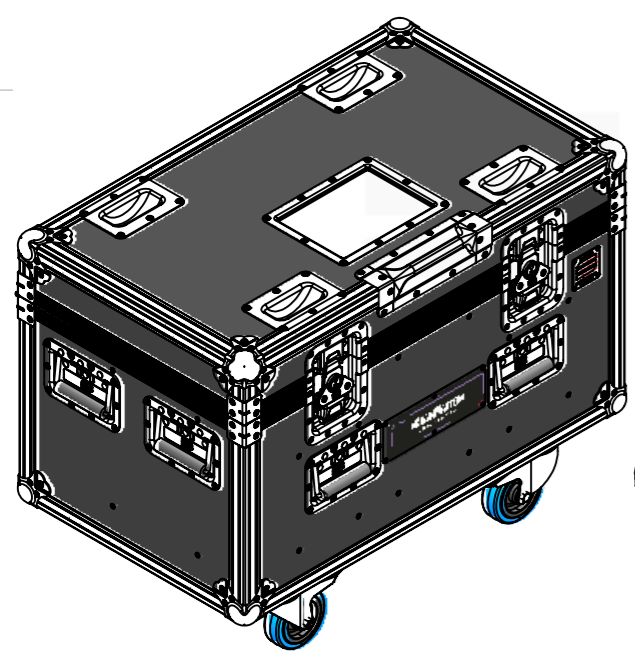
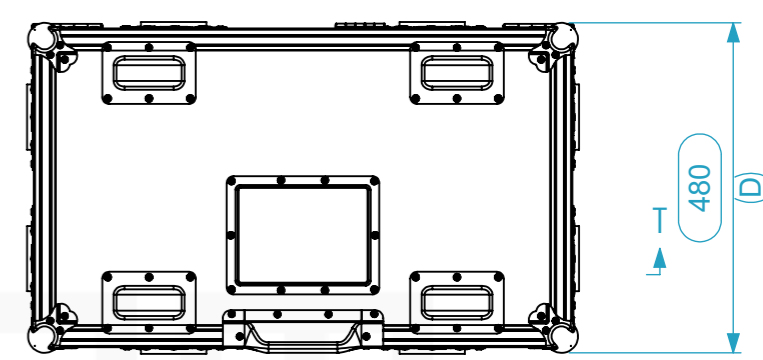
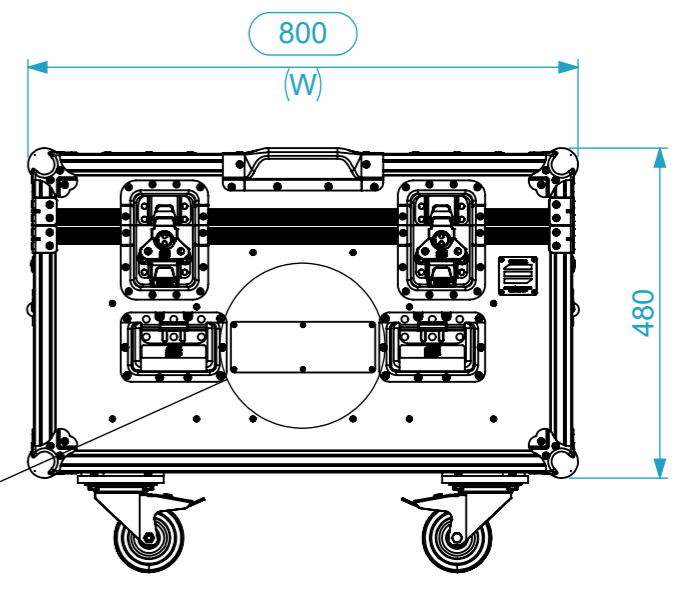
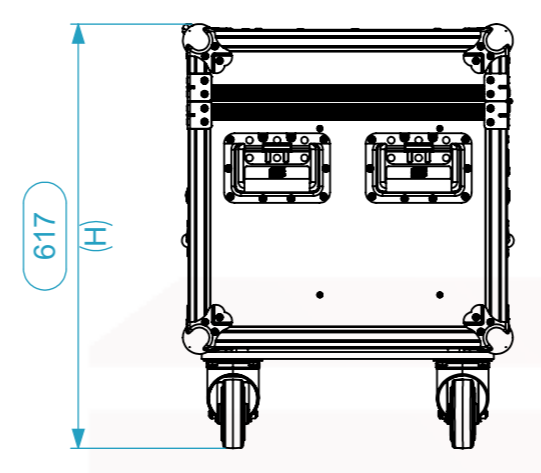
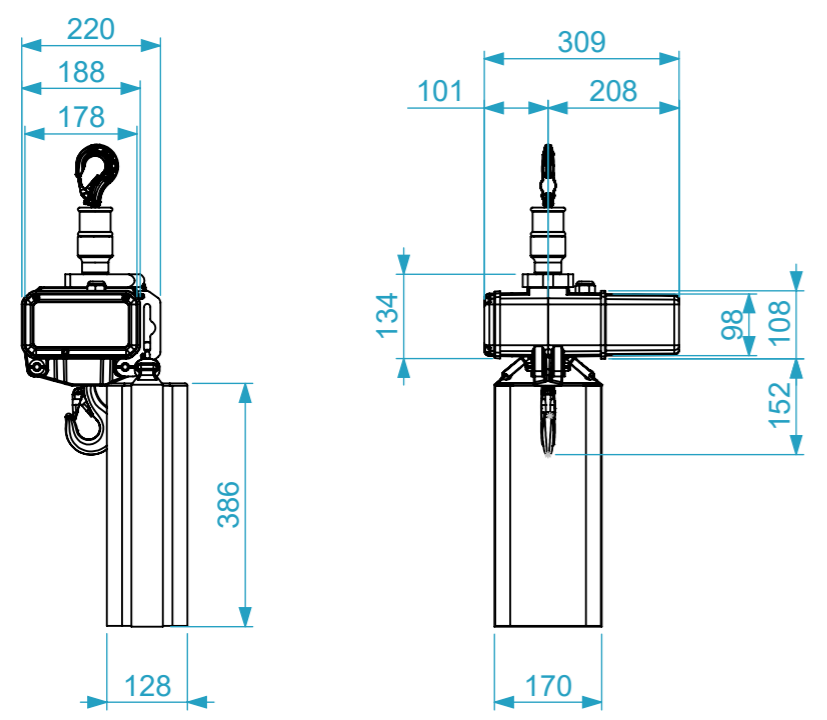

General External Dimensions	
W	Width
D	Depth
H	Height
Usable Inner Dimensions	
Wi	Inside Width
Di	Inside Depth
Hi	Inside Height
Wood Inner Dimensions	
WWi	Wood Inside Width
WDi	Wood Inside Depth
WHi	Wood Inside Height

MORE DETAILS IN THE NEXT PAGE

Name	Date
Drawn by	jose.couto 08/01/2025
Reference	LIFT.1.65
Scale	1:1
units in mm	general tolerance 0.8mm
DO NOT SCALE	
1st Angle projection	Flight case PRO, 2x ChainMaster ULTRA 250Kg



A3 This drawing must not be copied or disclosed without consent of the owner

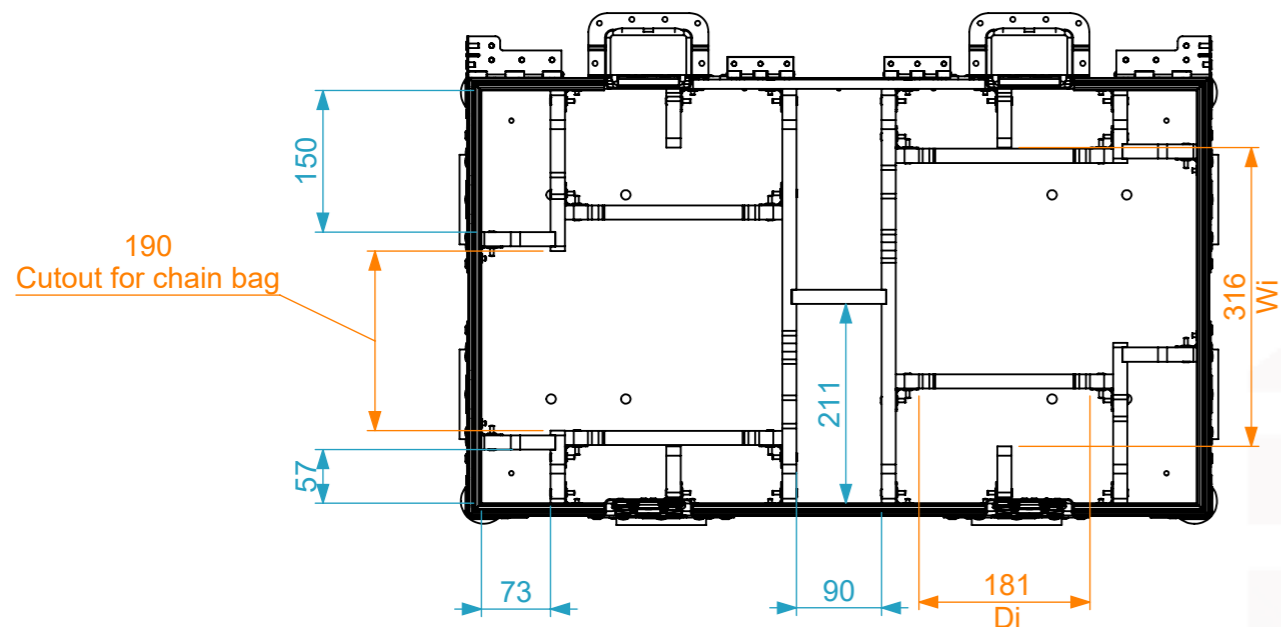

Adjustable
dividers

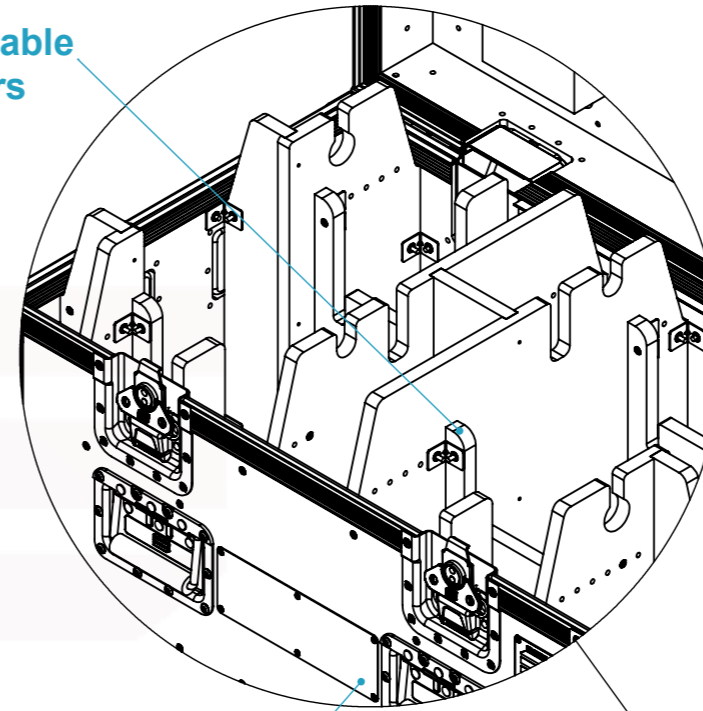

Metal plate with
printed hoist brand
and model

Compartment for
electrical cables
and socket

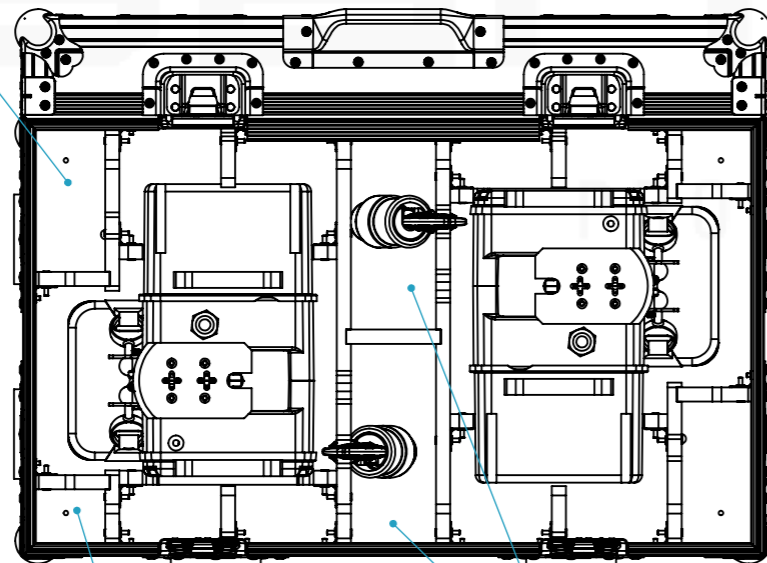

Compartment for
hoist bag

Compartments for
hoist chain

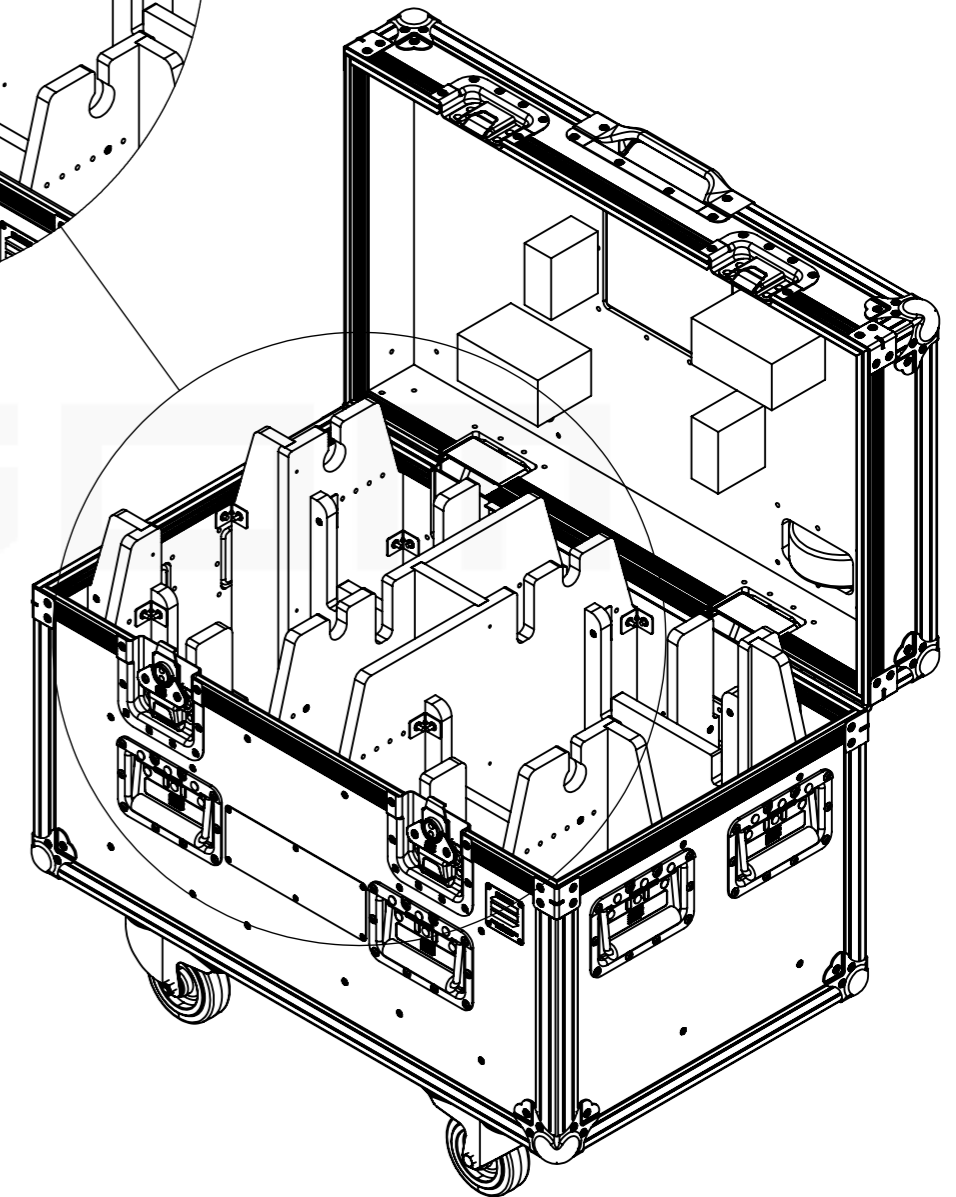

Drawn by	Name	Date
jose.couto	jose.couto	08/01/2025
Reference	LIFT.165	
Scale	units in mm	general tolerance 0.8mm
1:8	DO NOT SCALE	
Flight case PRO, 2x ChainMaster ULTRA 250Kg		



This drawing must not be
copied or disclosed without
consent of the owner



A3