

<b>Equipment</b>	ChainMaster D8+ Ultra 500 kg	
<b>Width</b>	<b>Depth</b>	<b>Height</b>
355	205	111
<b>Weight</b>	Approx. 43 Kg	
<b>Wall Thickness</b>	10mm	

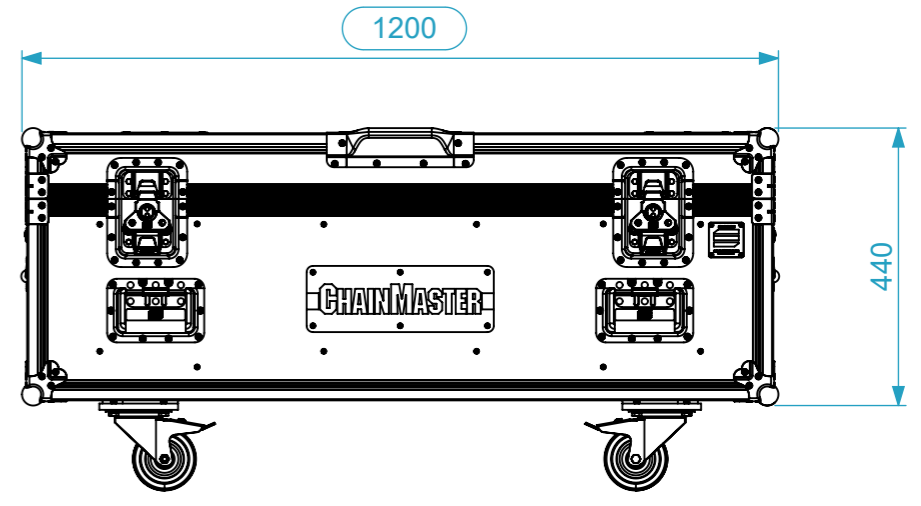
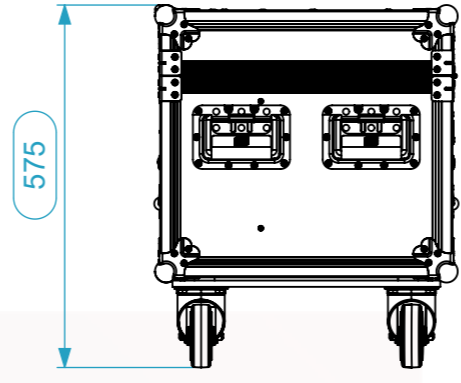
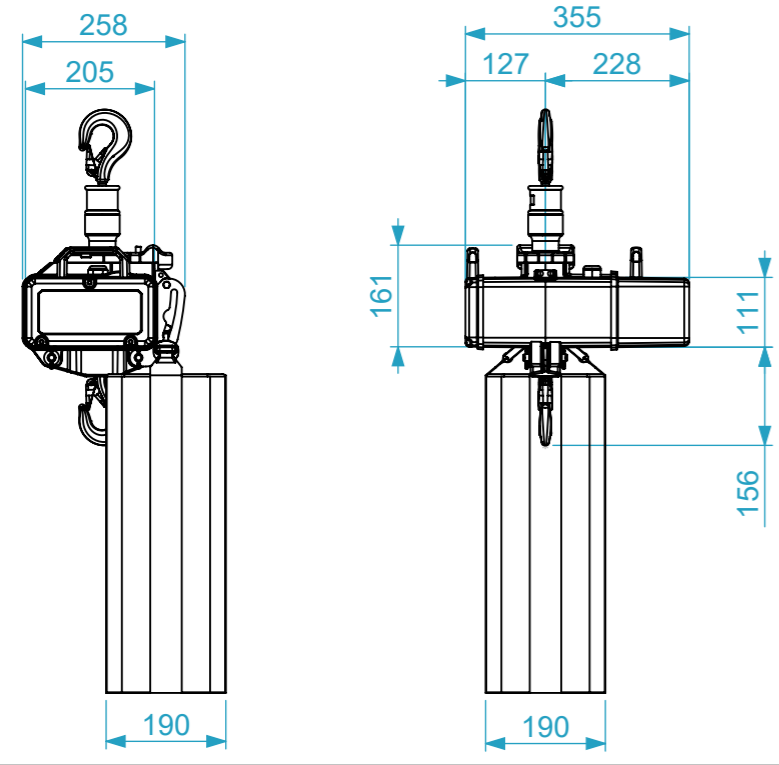

Cut-out for chain hook

Cut-out for chain

Cut-out for electrical cables

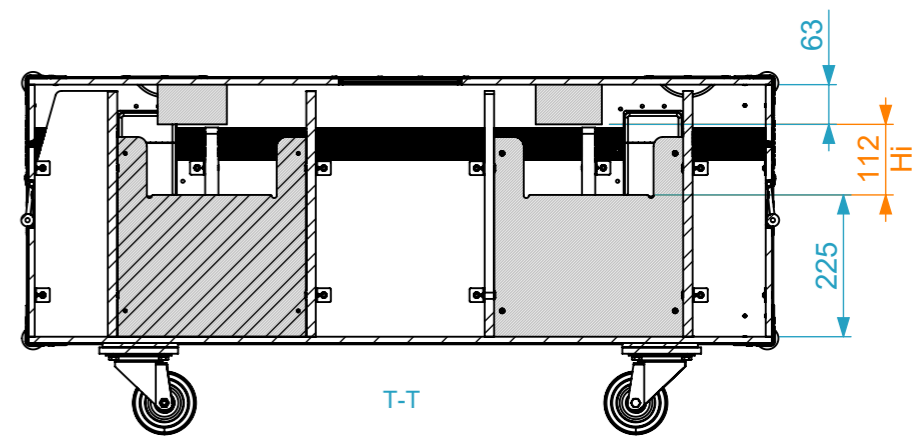
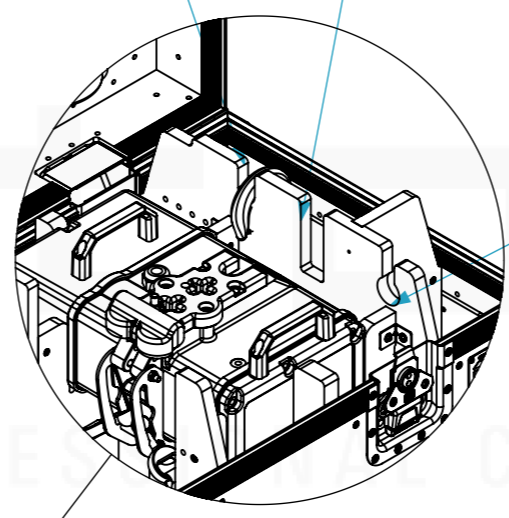
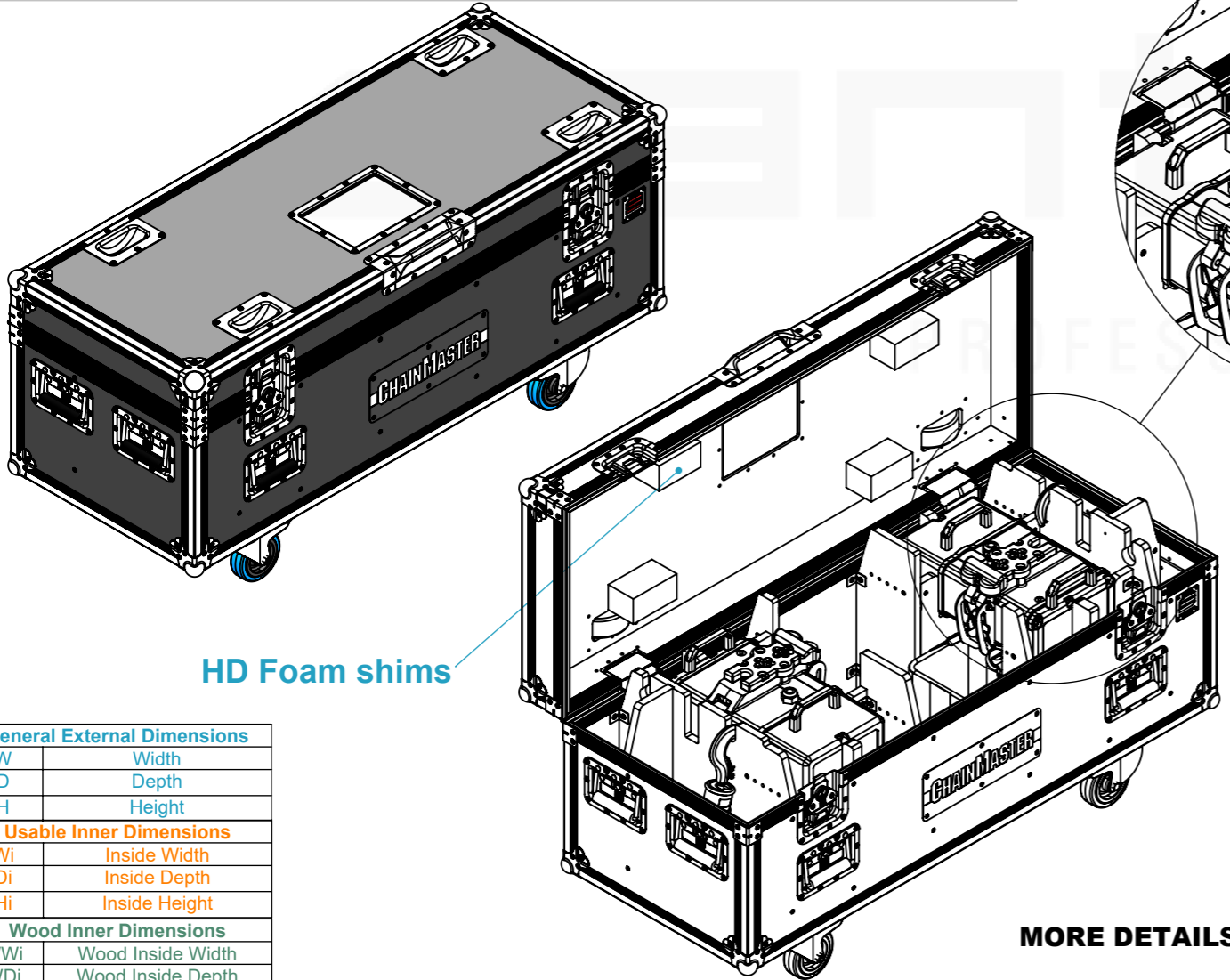
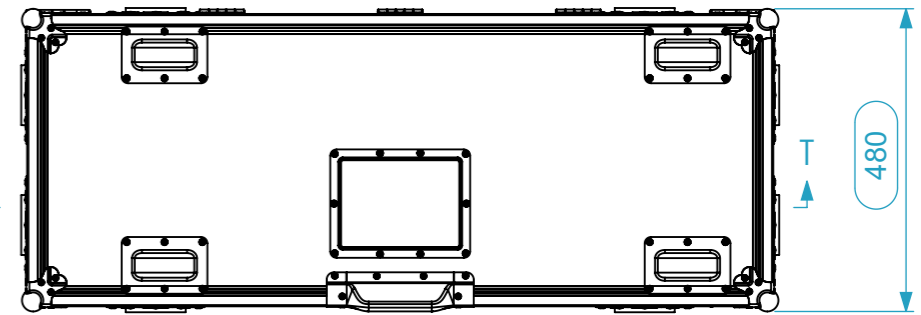

General External Dimensions	
W	Width
D	Depth
H	Height
Usable Inner Dimensions	
Wi	Inside Width
Di	Inside Depth
Hi	Inside Height
Wood Inner Dimensions	
WWi	Wood Inside Width
WDi	Wood Inside Depth
WHi	Wood Inside Height

**MORE DETAILS IN THE NEXT PAGE**

Name	Date
alexandre	11/06/2021
Reference	LIFT.162
Scale	1:12
units in mm	general tolerance 0.8mm
DO NOT SCALE	
Flight case PRO, 2x ChainMaster ULTRA 500Kg	



This drawing must not be copied or disclosed without consent of the owner



A3

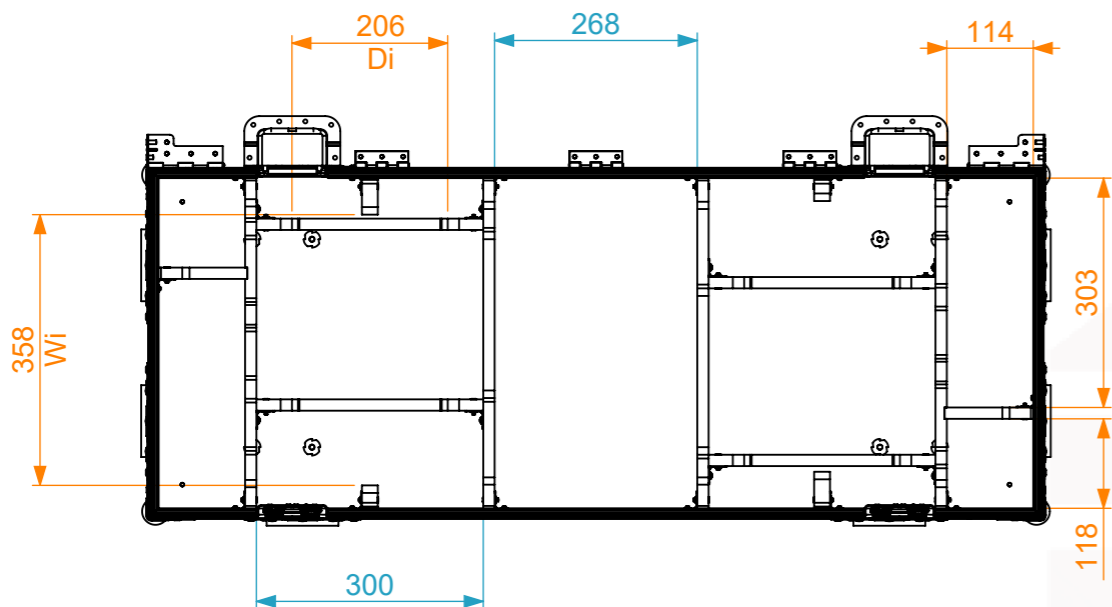

Adjustable divider

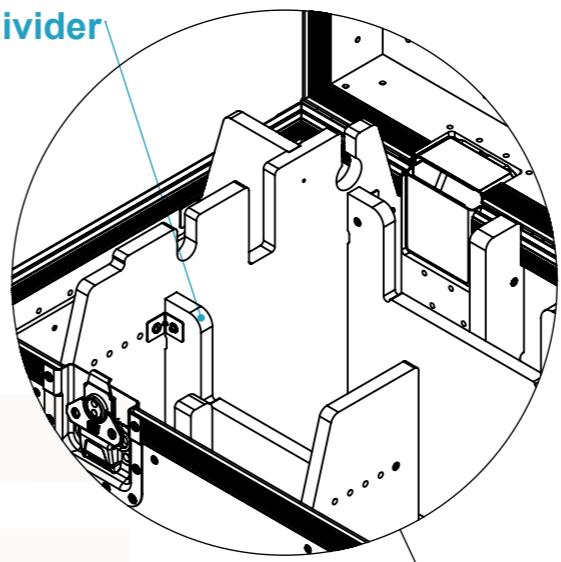

Compartment for electrical cables and socket

Compartment for the chain bags

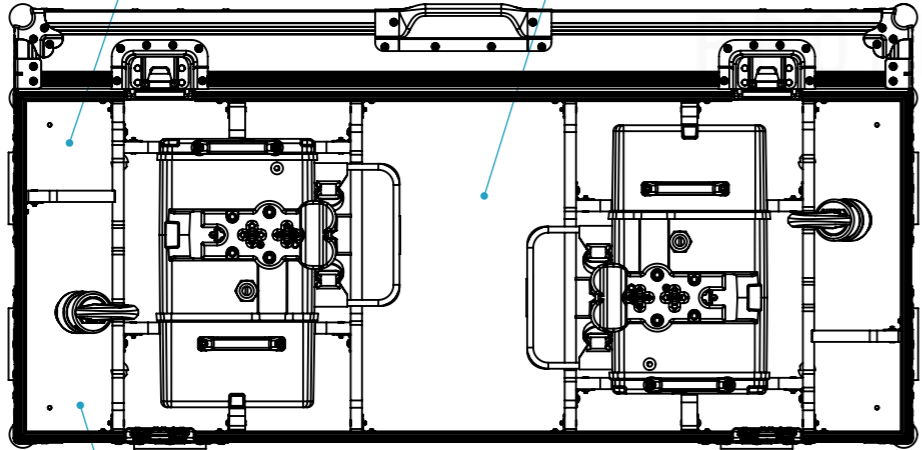

Compartments for hoist chain

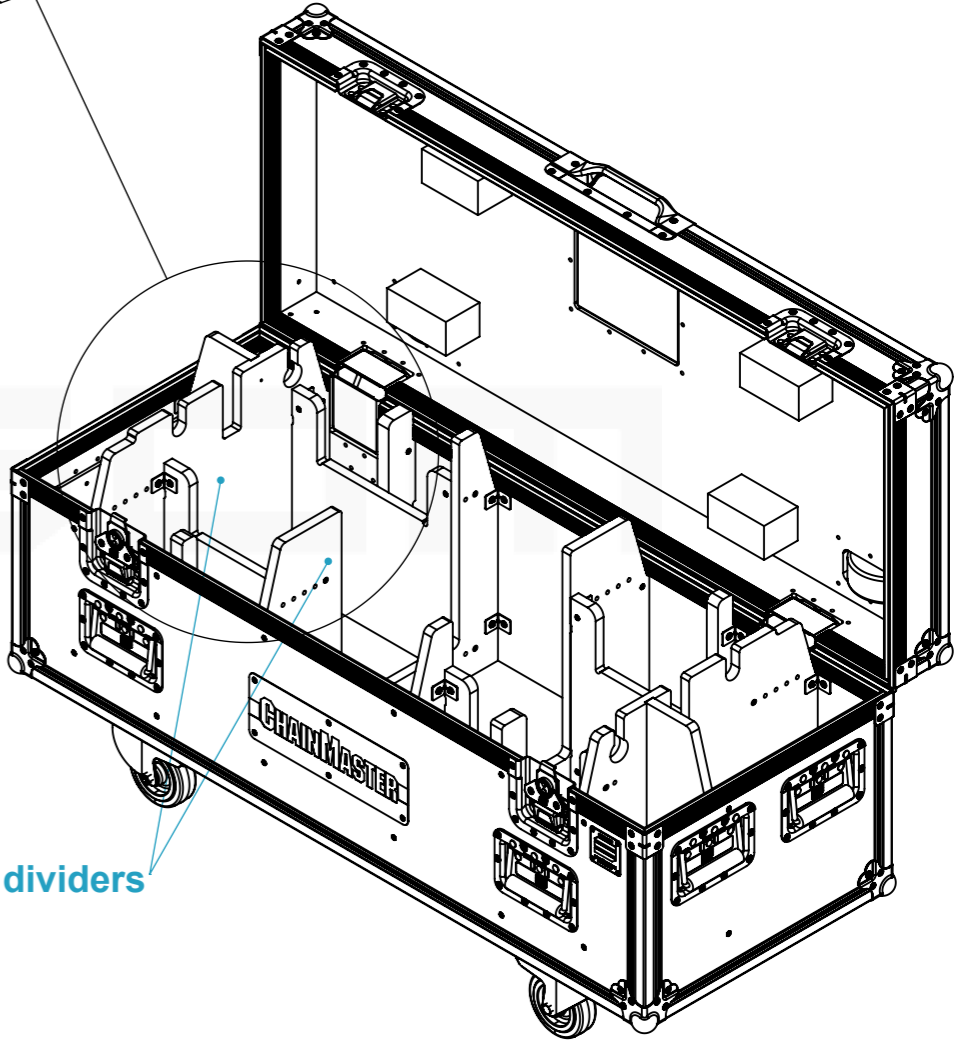

Drawn by	Name	Date
alexandre	alexandre	11/06/2021
Reference	LIFT.162	
Scale	units in mm	general tolerance
1:10	DO NOT SCALE	0.8mm
Flight case PRO, 2x ChainMaster ULTRA 500Kg		



This drawing must not be copied or disclosed without consent of the owner



A3